

WALLING SOLUTIONS



DESIGN & INSTALLATION MANUAL

CUSTOM ORB®
EASYCLAD®
MULTICLAD®

MINI ORB®
PANELRIB®
SPANDEK®

TRIMDEK®
TRIMWALL®
WALLCLAD™



INSPIRATION TO BUILD BETTER

WALLING SOLUTIONS

All LYSAGHT® roof claddings can be used for both roofing and walling. This brochure focuses on cladding profiles specifically designed for walling, but does include our three most popular roofing profiles which are also used for walls. All LYSAGHT® wall cladding products are made from Australian-made ZINCALUME® steel or COLORBOND® steel, so you know you are buying quality.

This brochure is a guide to the design and installation of steel walling manufactured by Lysaght. We intend that it is used by all trades and professions involved with specifying and applying the wide range of our products.

We refer only to genuine steel cladding manufactured by us and marketed under our brand names. Our recommendations should only be used for our products because they are based on testing of our profiles, base metal thicknesses (BMT) and material finishes.

WALLING DESIGN

The design of walling from a steel perspective is fairly straightforward. Once you have made the aesthetic decision of which profile to use, the main considerations are the support spacings, fixing details and the details of flashing.

MATERIAL SPECIFICATIONS

Next generation ZINCALUME® aluminium/zinc/magnesium alloy coated steel complies with AS 1397 G550, AM125 (550 MPa minimum yield stress, 125g/m² minimum coating mass).

COLORBOND® steel is pre-painted steel for exterior roofing and walling. It is the most widely used. The painting complies with AS/NZS 2728 and the steel base is an aluminium/zinc alloy-coated steel complying with AS 1397. Minimum yield strength is G550 (550 MPa). Minimum coating mass is AM100 (100g/m²).

COLORBOND® Metallic steel is pre-painted steel for superior aesthetic qualities displaying a metallic sheen.

COLORBOND® Ultra steel is pre-painted steel for severe coastal or industrial environments (generally within about 100-200 metres of the source). The painting complies with AS/NZS 2728 and the steel base is an aluminium/zinc alloy-coated steel complying with AS 1397. Minimum yield strength is G550 (550 MPa). Minimum coating mass is AM150 (150g/m²).

SUPERDURA® Stainless steel is a pre-painted steel for severe coastal or industrial environments. The painting complies with AS/NZS 2728 and the steel base is a stainless steel complying with AISI/ASTM Type 430; UNS No. S43000.

MATERIAL AND COLOUR AVAILABILITY

For local availability of your selected cladding in the base metal thicknesses or the large range of available finishes (from plain ZINCALUME® steel to COLORBOND® pre-painted steel), contact your nearest Lysaght service centre.

For the local availability of colours, metallic finish or stainless steel, please enquire at your nearest Lysaght service centre.

COLORBOND® STEEL WITH THERMATECH® TECHNOLOGY¹

COLORBOND® steel's core colour range in the Classic and Matt finish features our specially designed Thermatech® solar reflectance technology. Thermatech® reflects more of the sun's heat on hot, sunny days which may help increase your comfort while reducing your dependence on air conditioning. Thermatech® is available in all core colours except Night Sky®.

LIMIT STATE WIND PRESSURES

The wind pressure capacities are based on tests conducted at Lysaght's NATA registered testing laboratory using the direct pressure test rig. Testing was conducted in accordance with AS 1562.1, and AS 4040.1.

The pressure capacities for serviceability are based on a deflection limit of (span/120) + (maximum fastener pitch/30).

The pressure capacities for strength have been determined by testing the cladding to failure (ultimate capacity).

These pressures are applicable when the cladding is fixed to a minimum of 1.0mm, G550 steel.

For CUSTOM ORB®, CUSTOM BLUE ORB®, TRIMDEK® and SPANDEK® less than 1.0mm thick, refer to the TOPSPAN® Quick Selection Guide or seek advice from our information line.

ADVERSE CONDITIONS

If this product is to be used in marine, severe industrial, or unusually corrosive environments, ask for advice from our information line.

NON-CYCLONIC AREAS

The information in this brochure is suitable for use only in areas where a tropical cyclone is unlikely to occur as defined in AS/NZS 1170.2.

For information on the use of LYSAGHT® products in cyclonic conditions, refer to the Cyclonic Area Design Manual, available at: www.lysaght.com.



MAINTENANCE

Optimum product life will be achieved if all external walls are washed regularly. Areas not cleaned by natural rainfall (such as the tops of walls sheltered by eaves) should be washed down according to our maintenance guidelines.

SAFETY, STORAGE AND HANDLING

Handling Safety - LYSAGHT® product may be sharp and heavy. It is recommended that heavy-duty cut resistant gloves and appropriate manual handling techniques or a lifting plan be used when handling material.

Keep the product dry and clear of the ground. If stacked or bundled product becomes wet, separate it and dry thoroughly with a clean cloth. Handle materials carefully to avoid damage: don't drag materials over rough surfaces or each other; don't drag tools over material; protect from swarf.

METAL & TIMBER COMPATIBILITY

Lead, copper, free carbon, bare steel and green or some chemically-treated timber are not compatible with this product. Don't allow any contact of the product with those materials, nor discharge of rainwater from them onto the product. Supporting members should be coated to avoid problems with underside condensation. If there are doubts about the compatibility of other products being used, ask for advice from our information line.

CUTTING

Lengths are custom cut. Check maximum and minimum with your supplier.

For cutting thin metal on site, we recommend a circular saw with a metal-cutting blade because it produces fewer damaging hot metal particles (swarf) and leaves less resultant burr than does a carborundum disc.

Cut materials over the ground and not over other materials.

Sweep all metallic swarf and other debris from all surfaces and gutters at the end of each day and at the completion of the installation. Failure to do so can lead to surface staining when the metal particles rust.

FASTENERS

Where insulation is to be installed, you may need to increase the length of the screws given, depending on the density and thickness of the insulation. When the screw is properly tightened:

- **into metal:** there should be at least three threads protruding past the support you are fixing to, with rib fixed screws the Shankguard must not reach that support;
- **into timber:** the screw must penetrate the timber by the same amount that the recommended screw would do if there were no insulation.

SEALED JOINTS

For sealed joints use screws or rivets and neutral-cure silicone sealant branded as suitable for use with galvanised or ZINCALUME® steel.



SIDE-LAPS

Refer to the LYSAGHT® Roofing & Walling Installation Manual regarding side-laps. If added side-lap fastening is required then the choice of fastener should be to match the aesthetics of the installation with consideration of the features of the walling profile and its fixing fasteners.







The selection of side-lap fasteners is commonly from a 10-16x16 MetalTek HH; Roof Zips M6-11x25; M5-16x25 Designer Head; or 4.8mm Dia. aluminium Sealed Blind Rivet.

INSTALLATION ADVICE

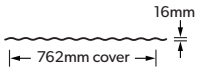
This manual provides some basic installation guidance on the specific claddings used for wall application. For more detailed installation advice, please refer to: LYSAGHT® Roofing and Walling Installation Manual (as current, referred to as the Installation Guide) which is available at www.lysaght.com or by calling Steel Direct 1800 641 417.

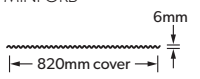
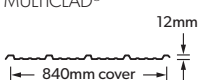
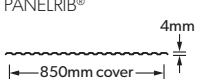
WALLING PROFILES

MAXIMUM SUPPORT SPACINGS FOR CLADDINGS USED AS WALLING

	BMT	Cover Width	Rib Depth	Maximum recommended spacing of wall supports			
				Single	End	Internal	Overhang
	mm	mm	mm	mm	mm	mm	mm
CUSTOM ORB®	0.42	762	16	1800	2500	2700	200
	0.48	762	16	1800	2700	2700	250
EASYCLAD® 2PF 300	0.42	300	19	-	1500	1500	100
							
MINI ORB®	0.42	820	6	1200	1500	1500	100
							
MULTICLAD®	0.35	840	12	1400	1800	1800	150
	0.42	840	12	1700	1800	1800	150
PANELRIB®	0.35	850	4	1100	1200	1200	150
	0.42	850	4	1200	1200	1200	150
SPANDEK®	0.42	700	24	2500	3000	3300	300
	0.48	700	24	3000	3000	3300	400
TRIMDEK®	0.42	762	29	2400	3000	3000	150
	0.48	762	29	2700	3000	3000	200
TRIMWALL®	0.35	762	29	2100	2900	3000	150
							
WALLCLAD™	0.35	762	16	1800	2400	2400	150
							

MAXIMUM SUPPORT SPACINGS

The maximum recommended support spacings (above) based on testing in accordance with AS 1562.1, and AS 4040.2.

For walls, the following conditions apply:

- Buildings up to 10m high in Region B Terrain Category 3
 $M_s = 0.85$, $M_l = 1.0$, $M_t = 1.0$
- $C_{pi} = 0.20$, $C_{pe} = -0.65$, $K_1 = 2.0$ for single and end spans, $K_1 = 1.5$ for internal spans. These spacings may vary by serviceability and strength limit states for particular projects. Values provided according to AS/NZS 1170.2.

For support spacings in wind conditions other than those shown, refer to the wind pressure data.

SPAN TYPES

Walling Applications Only

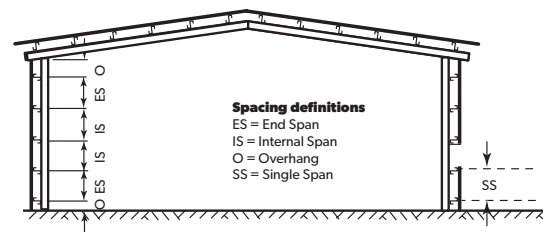

TOLERANCES

For length and cover width tolerances refer to your nearest service centre for advice. Generally the following applies;

Cover width tolerances do not exceed +4mm -4mm, however some profiles may be available with a tighter tolerance

Length tolerance do not exceed the limits of +10mm -15mm. Commonly the tolerances are +0mm -15mm however some profiles have differing tolerance, such as +10mm -10mm, and others may be available with tighter tolerances.

Tighter tolerances may be available subject to enquiry.

OPTIONAL WALL TRIMS

AVAILABLE IN ZINCALUME® STEEL OR COLORBOND® STEEL*

Our range of wall trims are available for the range of LYSAGHT® cladding profiles to provide an attractive compliment to walls, ceilings or soffits. Below is a selection of trims.

Some trims are used to start the installation of the walling panels whilst others provide the perfect finishing touch.

Made from COLORBOND® steel or ZINCALUME® steel*, they are an attractive, long lasting addition to any walling installation.

Not all trims are available in all locations and some dimensions may vary from state to state - for local availability of wall trims, contact your local sales office.

*Availability of other materials, such as stainless steel and COLORBOND® Ultra steel are subject to enquiry.

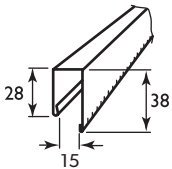

CD 1 Trim Channel

Use with MULTICLAD® and EASYCLAD®

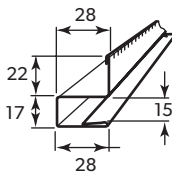

CD 3 Fascia to Soffit Section

Use with PANELRIB®, MINI ORB®, EASYCLAD®, MULTICLAD®

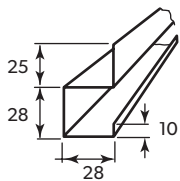

CD 4 Feature Section Soffit

Use with PANELRIB®, MINI ORB®, EASYCLAD®, MULTICLAD®

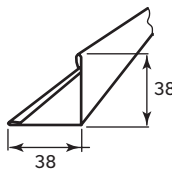

CD 5 External Corner

Use with PANELRIB®, MULTICLAD®, EASYCLAD® and MINI ORB®

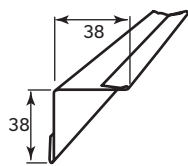

CD 6 Internal Corner

Use with PANELRIB®, MULTICLAD®, EASYCLAD® and MINI ORB®

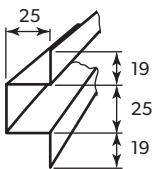

CD 8 Purlin Hat Section

Use with MULTICLAD® and EASYCLAD®

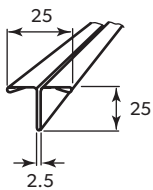

CD 15 Tee Section

Use with PANELRIB®, MULTICLAD®, EASYCLAD® and MINI ORB®

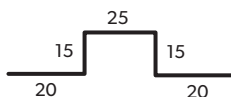

CD 20 Butt Joint Trim - Top Hat

Use with PANELRIB®, MULTICLAD® and MINI ORB®

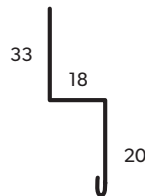

CD 21 Butt Joint Trim - Overlap

Use with MULTICLAD®

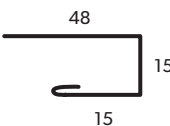

CD 22 Edge Trim

Use with MULTICLAD® and MINI ORB® (Enquiry only in S.A.)

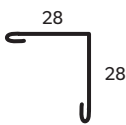

CD 23 External Corner

Use with PANELRIB®, MULTICLAD®, EASYCLAD® and MINI ORB®

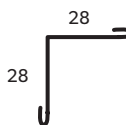

CD 24 Internal Corner

Use with PANELRIB®, MULTICLAD®, EASYCLAD® and MINI ORB®

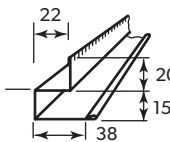

CD 27 Fascia to Soffit Section

Use with PANELRIB®, MULTICLAD®, EASYCLAD® and MINI ORB®

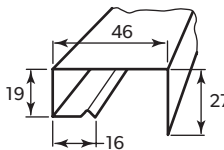

CD 30 Fascia Capping

Use with PANELRIB®, MULTICLAD®, TRIMWALL®, EASYCLAD® and MINI ORB®

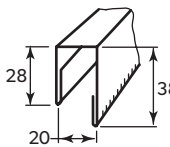

CD 39 Trim Channel

Use with EASYCLAD®

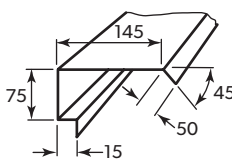

EC 3 Fascia Capping

Use with PANELRIB®, MULTICLAD®, TRIMWALL®, EASYCLAD® and MINI ORB®



CD 40 Starter Clip

Use with EASYCLAD®

CD40 Starting clip

CUSTOM ORB®

CUSTOM ORB® is the classic corrugated cladding. It is ideal for traditional or contemporary design and is the most popular LYSAGHT® profile.

It is long, wide, strong, lightweight and economical and it can be fixed quickly and easily.

CUSTOM ORB® is versatile so it can be used for commercial, industrial and residential buildings.

CUSTOM ORB® can be gently curved and this is reflected in some of today's most adventurous and dramatic designs.

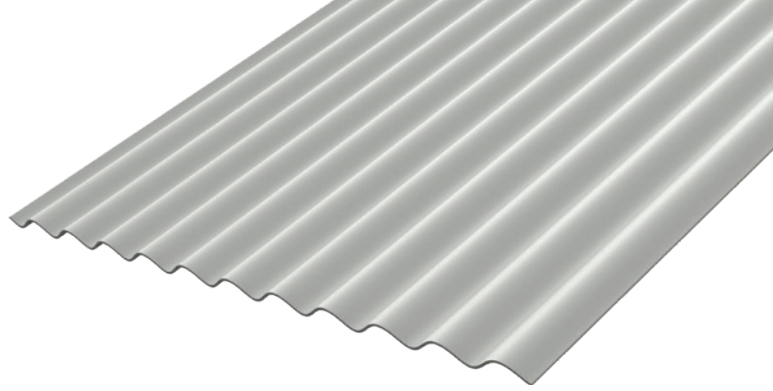

MASSES

	BMT (mm)	kg/m ²
ZINCALUME® steel	0.42	4.23
COLORBOND® steel	0.42	4.27
ZINCALUME® steel	0.48	4.81
COLORBOND® steel	0.48	4.85

SHEET COVERAGE

Width of Wall (m)	3	4	5	6	7	8	9	10	11	12	13	14	15	16	17	18	19	20	30	40	50
Number of Sheets	4	6	7	8	10	11	12	14	15	16	18	19	20	21	23	24	25	27	40	53	66

CUSTOM ORB® LIMIT STATE WIND PRESSURE CAPACITIES (KPA) 0.42 BMT

Span Type	Fasteners per sheet per support	Limit State	Span (mm)							
			600	900	1200	1500	1800	2100	2400	2700
Single	3	Serviceability	1.91	1.46	1.08	0.77	0.49	-	-	-
		Strength	12.00	8.60	5.80	4.65	4.50	-	-	-
	5	Serviceability	5.39	3.20	1.75	0.94	0.45	-	-	-
		Strength	12.00	12.00	10.15	8.10	7.40	-	-	-
End	3	Serviceability	1.66	1.40	1.18	1.00	0.83	0.67	0.52	0.38
		Strength	9.15	7.55	5.90	4.50	3.40	2.70	2.30	2.00
	5	Serviceability	6.08	4.27	2.79	1.59	1.02	0.65	0.42	0.30
		Strength	12.00	12.00	9.90	7.55	5.75	4.50	3.60	3.05
Internal	3	Serviceability	1.91	1.67	1.45	1.23	1.03	0.85	0.69	0.56
		Strength	11.35	9.25	7.45	6.00	4.85	3.90	3.20	2.70
	5	Serviceability	7.00	4.92	3.32	2.21	1.49	1.05	0.78	0.59
		Strength	12.00	12.00	12.00	10.80	8.85	7.10	5.65	4.50

CUSTOM ORB® LIMIT STATE WIND PRESSURE CAPACITIES (KPA) 0.48 BMT

Span Type	Fasteners per sheet per support	Limit State	Span (mm)							
			600	900	1200	1500	1800	2100	2400	2700
Single	3	Serviceability	2.12	1.47	1.03	0.77	0.60	-	-	-
		Strength	12.00	9.80	6.55	5.30	5.10	-	-	-
	5	Serviceability	7.48	3.74	2.23	1.26	0.57	-	-	-
		Strength	12.00	12.00	10.75	8.65	8.10	-	-	-
End	3	Serviceability	1.92	1.66	1.48	1.35	1.19	1.01	0.81	0.60
		Strength	11.70	9.05	6.80	4.95	4.10	3.45	3.00	2.65
	5	Serviceability	8.00	4.75	2.86	1.97	1.39	0.97	0.66	0.44
		Strength	12.00	12.00	12.00	10.60	8.00	6.20	5.00	4.25
Internal	3	Serviceability	1.98	1.96	1.84	1.62	1.36	1.07	0.82	0.62
		Strength	12.00	10.15	8.50	7.10	5.70	4.55	3.60	2.90
	5	Serviceability	9.00	5.42	4.34	3.31	2.37	1.57	0.95	0.54
		Strength	12.00	12.00	12.00	12.00	11.00	8.65	6.75	5.25

Refer to notes on Limit State Wind Pressure on page 2 of this brochure.

CUSTOM ORB® INSTALLATION AS WALLING

FASTENERS WITHOUT INSULATION

	Fix to Steel Single & lapped steel thickness ≥0.55 up to 1.0mm BMT	Fix to Steel Single steel thickness ≥1.0mm BMT up to 3.0mm BMT	Fix to Steel Total lapped thickness ≥1.00 BMT up to 3.8mm BMT	Fix to Timber Hardwood J1-J3	Fix to Timber Softwood J4
Crest Fixed	Roof Zips M6-11x50	12-14x35, Metal Tekes HG, HH or AutoTekes M5.5-14x39	12-14x35, Metal Tekes HG, HH or AutoTekes M5.5-14x39	12-11x50, Type 17 HG, HH	12-11x50, Type 17 HG, HH or Roof Zips M6-11x50
Valley Fixed	10-16x16, Metal Tekes, HH or M5-16x25 Designer Head or Roof Zips M6-11x25	10-16x16, Metal Tekes, HH or M5-16x25 Designer Head	10-16x16, Metal Tekes, HH	10-12x20, Type 17, HH or M5-16x25 Designer Head	10-12x30, Type 17, HH or M5-16x25 Designer Head or Roof Zips M6-11x25
Side-laps	10-16x16, Metal Tekes, HH or Roof Zips M6-11x25 or M5-16x25 Designer Head or Sealed blind rivet ø4.8mm				

Notes:

1. For other steel thicknesses not specified please seek advice from screw manufacturer.
2. Values given are: gauge/threads per inch/ lengths (mm). HH = Hex. Head, WH = Wafer Head, HG = Hi-Grip
3. Care is required during installation to prevent stripping of thin material. (Single ply.)
4. Screw specification as above or equivalent fastener.
5. All screws with EPDM sealing washer.

FASTENING SHEETS TO SUPPORTS

CUSTOM ORB® is pierce-fixed to timber or steel supports. This means that fastener screws pass through the sheeting.

You can place screws through the crests or in the valleys. For walling, valley-fixing is the standard industry practice.

Always drive the screws perpendicular to the sheeting, and in the centre of the corrugation or crest.

Don't place fasteners less than 25mm from the ends of sheets.

SIDE-LAPS

CUSTOM ORB® is overlapped at the sides not less than 1.5 corrugations. It is generally considered good practice to use fasteners along side-laps however, when cladding is supported as indicated in maximum support spacings, side-lap fasteners are not usually needed when crest fixed. When valley-fixed, the cladding needs a side-lap fastener in all laps, at each support.

END-LAPPING

End-laps are not usually necessary because CUSTOM ORB® is available in long lengths.

If you want end-laps, refer to the LYSAGHT® Roofing and Walling Installation Manual.

If you intend to end-lap CUSTOM ORB®, order the sheets at the same time and tell us you intend to lap them, to ensure a good fit of the profiles.

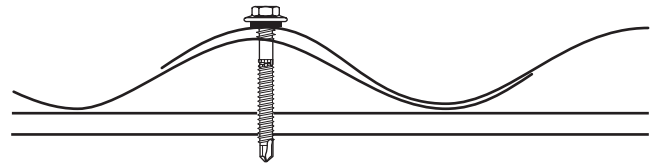

Crest fixing

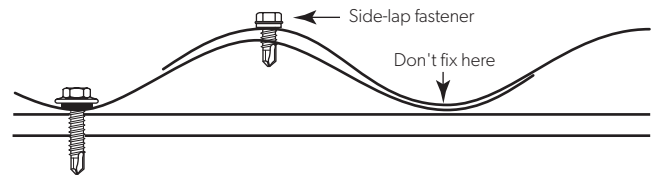

Valley fixing

Crest: 3 fasteners †



Valley: 3 fasteners †



Crest: 5 fasteners †



Valley: 5 fasteners †



† Fasteners per sheet per support. Most common practice is: 3 fasteners for internal spans and 5 fasteners for single and end.

EASYCLAD®

(NOT AVAILABLE IN W.A.)

EASYCLAD® is used for walls, ceilings, infill panels and screens.

Stylish, clean-line panels are available with a wide range of trim sections and accessories.

High impact resistance due to profile strength.

There is a wide range of trim sections. Refer to page 5.



MASSES

	BMT (mm)	kg/m ²
ZINCALUME® steel	0.42	4.46
COLORBOND® steel	0.42	4.50



SHEET COVERAGE

Width of Wall (m)	3	4	5	6	7	8	9	10	11	12	13	14	15	16	17	18	19	20	30	40	50
Number of Sheets	10	14	17	20	24	27	30	34	37	40	44	47	50	54	57	60	64	67	100	134	167

EASYCLAD® 2PF 300 LIMIT STATE WIND PRESSURE CAPACITIES (KPA) 0.42 BMT

Span Type	Limit State	Span (mm)							
		450	600	750	900	1050	1200	1350	1500
End	Serviceability	1.39	1.36	1.33	1.28	1.23	1.17	1.10	1.04
	Strength	4.85	3.85	3.10	2.50	2.20	2.00	1.85	1.80
Internal	Serviceability	1.28	1.26	1.23	1.20	1.15	1.11	1.05	1.01
	Strength	4.85	3.85	3.10	2.50	2.20	2.00	1.85	1.80

Refer to notes on Limit State Wind Pressure on page 2 of this brochure.

EASYCLAD® INSTALLATION

EASYCLAD® can be attached to the supporting frame with the panels either running vertical or horizontal.

The first panel is held in place by a CD 40 starting clip, flashing or by a trim channel fitted over the panel. The underlapping side of this panel is then fastened to each support adjacent to the return lip. The next panel is then overlapped and hooked over the return lip, with the underlapping side being fastened as previous. The laying of subsequent sheets follows this procedure.

For aesthetic reasons, end-laps are not recommended.

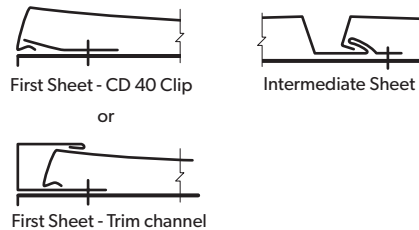

FASTENERS WITHOUT INSULATION

	Fix to Steel (Total 2.0mm BMT) Single & lapped steel thickness ≥0.55 up to 1.0mm BMT	Fix to Steel Single steel thickness ≥1.0mm BMT up to 3.0mm BMT	Fix to Steel (Total 3.8mm BMT) Lapped thickness ≥1.00 BMT up to 1.9mm BMT	Fix to Timber Hardwood J1-J3	Fix to Timber Softwood J4
Clip and Pan Fixed	10-16x16, Metal Tek's, HH or M5-16x25 Designer Head or Roof Zips M6-11x25	10-16x16, Metal Tek's, HH or M5-16x25 Designer Head	10-16x16, Metal Tek's, HH	10-12x25, Type 17, HH or M5-16x25 Designer Head	10-12x30, Type 17, HH or M5-16x25 Designer Head or Roof Zips M6-11x25

Notes:

- For other steel thicknesses not specified please seek advice from screw manufacturer.
- Values given are: gauge/threads per inch/ lengths (mm). HH = Hex. Head, WH = Wafer Head, HG = Hi-Grip
- Care is required during installation to prevent stripping of thin material. (Single ply)
- Screw specification as above or equivalent fastener.
- All screws with EPDM sealing washer.



MULTICLAD®

MULTICLAD® is an attractive trapezoidal multi-ribbed profile.

The 840mm wide cover of the MULTICLAD® profile makes it one of the most economical LYSAGHT® wall claddings. This also means it is quick to install.

MULTICLAD® is usually used where an inexpensive, quick to install cladding is desirable, such as garages, carports and sheds. The speed of installation also makes it popular for commercial and industrial projects such as warehouses, showrooms and retail premises.

For aesthetic reasons, end-laps are not recommended.

Refer to page 5 for trims.



MASSES

	BMT (mm)	kg/m ²
ZINCALUME® steel	0.35	3.23
COLORBOND® steel	0.35	3.26
ZINCALUME® steel	0.42	3.84
COLORBOND® steel	0.42	3.88

SHEET COVERAGE

Width of Wall (m)	3	4	5	6	7	8	9	10	11	12	13	14	15	16	17	18	19	20	30	40	50
Number of Sheets	4	5	6	8	9	10	11	12	14	15	16	17	18	20	21	22	23	24	36	48	60

MULTICLAD® LIMIT STATE WIND PRESSURE CAPACITIES (KPA) 0.35 BMT

Span Type	Limit State	Span (mm)												
		600	700	800	900	1000	1100	1200	1300	1400	1500	1600	1700	1800
Single	Serviceability	1.83	1.58	1.34	1.11	0.90	0.72	0.57	0.45	0.36	0.30	0.26	0.23	0.21
	Strength	10.25	9.60	8.90	8.30	7.65	7.05	6.45	5.90	5.35	4.85	4.35	3.90	3.40
End	Serviceability	2.13	1.87	1.61	1.38	1.16	0.96	0.81	0.68	0.60	0.54	0.49	0.47	0.45
	Strength	5.85	5.10	4.50	4.00	3.55	3.15	2.85	2.60	2.40	2.20	2.05	1.90	1.80
Internal	Serviceability	2.19	2.13	2.07	1.99	1.91	1.80	1.68	1.52	1.34	1.14	0.93	0.71	0.49
	Strength	7.10	6.50	5.95	5.45	4.95	4.50	4.10	3.80	3.55	3.30	3.15	3.00	2.85

MULTICLAD® LIMIT STATE WIND PRESSURE CAPACITIES (KPA) 0.42 BMT

Span Type	Limit State	Span (mm)												
		600	700	800	900	1000	1100	1200	1300	1400	1500	1600	1700	1800
Single	Serviceability	2.31	2.06	1.81	1.58	1.36	1.15	0.97	0.81	0.68	0.56	0.46	0.37	0.29
	Strength	12.00	12.00	11.30	10.55	9.75	9.00	8.25	7.55	6.85	6.20	5.55	4.95	4.30
End	Serviceability	2.64	2.44	2.25	2.06	1.88	1.70	1.53	1.36	1.20	1.04	0.89	0.74	0.60
	Strength	8.80	7.95	7.15	6.35	5.65	5.00	4.50	4.05	3.70	3.45	3.25	3.10	2.95
Internal	Serviceability	2.72	2.55	2.39	2.23	2.06	1.89	1.72	1.54	1.35	1.17	0.98	0.79	0.60
	Strength	9.15	8.30	7.45	6.65	5.90	5.30	4.75	4.35	4.05	3.80	3.65	3.55	3.50

Refer to notes on Limit State Wind Pressure on page 2 of this brochure.

FASTENERS WITHOUT INSULATION

	Fix to Steel (Total 2.0mm BMT) Single & lapped steel thickness ≥0.55 up to 1.0mm BMT	Fix to Steel Single steel thickness ≥1.0mm BMT up to 3.0mm BMT	Fix to Steel (Total 3.8mm BMT) Lapped thickness ≥1.00 BMT up to 1.9mm BMT	Fix to Timber Hardwood J1-J3	Fix to Timber Softwood J4
Pan Fixed	10-16x16, Metal Tek's, HH or M5-16x25 Designer Head or Roof Zips M6-11x25	10-16x16, Metal Tek's, HH or M5-16x25 Designer Head	10-16x16, Metal Tek's, HH	10-12x25, Type 17, HH or M5-16x25 Designer Head	10-12x30, Type 17, HH or M5-16x25 Designer Head or Roof Zips M6-11x25

Notes:

- For other steel thicknesses not specified please seek advice from screw manufacturer.
- Values given are: gauge/threads per inch/lengths (mm). HH = Hex. Head, WH = Wafer Head, HG = Hi-Grip
- Care is required during installation to prevent stripping of thin material. (Single ply.)
- Screw specification as above or equivalent fastener.
- All screws with EPDM sealing washer.

4 fasteners per sheet/support



MINI ORB®

MINI ORB® is a corrugated sheet with reduced height of corrugation to the more traditional CUSTOM ORB® profile.

It is suitable for interior and exterior applications; on straight or curved surfaces; with the corrugations running vertically or horizontally.

MINI ORB® is primarily used for decorative finishes on walls, ceilings and soffit linings; feature walls and partitions; and screens and small awnings not subject to any foot traffic. It is a product that gives you freedom in design, allowing your creativity to blend perfectly with the practical.

However, MINI ORB®'s attractive profile makes it suitable for a myriad of original design applications, such as furniture; fencing and gates; awnings and shop fittings; and interior ceilings in both the industrial and domestic markets.

In WA contact the nearest Lysaght office for product information.

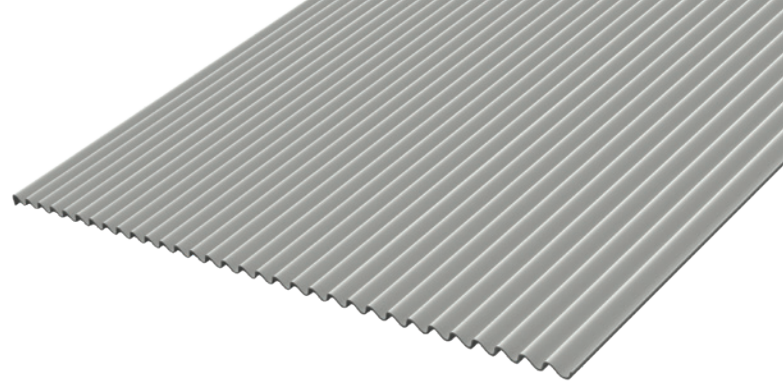

MASSES

	BMT (mm)	kg/m ²
ZINCALUME® steel	0.42	3.93
COLORBOND® steel	0.42	3.97

SHEET COVERAGE

Width of Wall (m)	3	4	5	6	7	8	9	10	11	12	13	14	15	16	17	18	19	20	30	40	50
Number of Sheets	4	5	7	8	9	10	11	13	14	15	16	18	19	20	21	22	24	25	37	49	61

MINI ORB® LIMIT STATE WIND PRESSURE CAPACITIES (KPA) 0.42 BMT

Span Type	Fasteners per sheet per support	Limit State	Span (mm)				
			450	600	900	1200	1500
Single	6	Serviceability	6.20	3.99	1.17	0.35	-
		Strength	11.70	10.15	7.65	5.70	-
	11	Serviceability	6.30	3.93	0.96	0.19	-
		Strength	12.00	12.00	12.00	10.40	-
End	6	Serviceability	6.50	4.69	2.17	1.00	0.34
		Strength	8.80	7.30	5.10	3.95	3.15
	11	Serviceability	6.12	4.33	1.89	0.87	0.40
		Strength	12.00	12.00	9.35	7.20	5.75
Internal	6	Serviceability	7.00	5.23	2.67	1.33	0.46
		Strength	11.70	9.25	5.85	4.30	3.50
	11	Serviceability	7.20	5.01	2.06	0.88	0.37
		Strength	12.00	12.00	10.70	8.10	6.35

Refer to notes on Limit State Wind Pressure on page 2 of this brochure.

CURVING INFORMATION

MINI ORB® may be spring curved down to 1500mm radius. It is suitable for pre-curving—the minimum radius of curve is 150mm, and the minimum straight length after a curve is 50mm.

Pre-curving is subject to enquiry as a lead time applies.

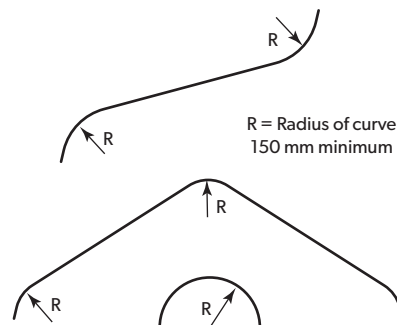

MINI ORB® INSTALLATION

You will always get a better appearance by taking a little extra care to ensure an evenly finished job, with uniform light reflection. Make sure that the supporting structure is as rigid and as flat as possible.

The information in this brochure is based on sheets being overlapped by 1.5 corrugations.

Always use at least two people to install MINI ORB®.

SUPPORT SPACINGS

The maximum support spacing are provide, however for particular application the following should be considered.

For ceilings the industry practice is to commonly 900mm, however the support spacing should not exceed 1200mm.

For best aesthetic results on all situations, limit the support spacing to 900mm.

INSTALLATION

The installation process for walls and ceilings is the same. For walls the MINI ORB® can be orientated horizontally, vertically or inclined.

Decide how the sheet width will best cover the area, giving each overlap the same number of corrugations. Overlaps of more than two or three corrugations may detract from the final look of the installation.

Start fixing near the centre of the sheet on the one edge (underlapping edge) and work outwards towards the ends of the sheet. Place successive rows of fasteners parallel with the first row, working similarly from the centre.

If the sheet is long (about 3000mm or longer), be very careful that the sheet remains parallel/straight, along both edges.

Take care the corrugations are not flattened, thus forcing the sheets to become wider.

TRIMS

Refer to Page 5 for range of wall trims. Contact your local Lysaght representative for availability.

END-LAPS

For aesthetic reasons, end-laps are not recommended.

FASTENING

MINI ORB® should be fixed to all intermediate battens or studs to prevent noise if the sheet flexes with pressure fluctuations in the building.

Fix fasteners no less than 15mm from ends of sheets.

TRIMS

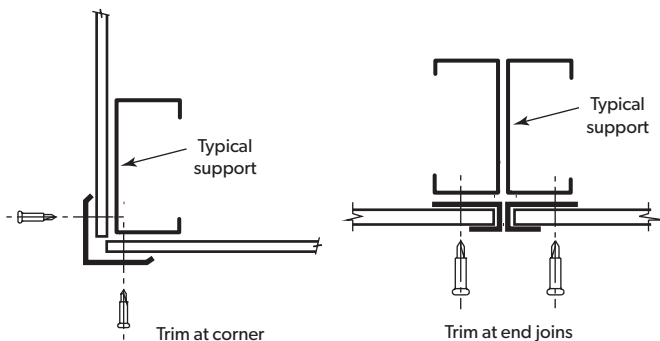

MINI ORB® FASTENERS

	Fix to Steel Total thickness up to 3.0mm BMT	Fix to Timber J1-J4
Valley Fixed	RippleZips® screws M4.8-16x25	RippleZips® screws M4.8-16x25

Notes:

1. For other steel thicknesses not specified please seek advice from screw manufacturer.
2. Values given are: gauge/threads per inch/ lengths (mm).
3. Care is required during installation to prevent stripping of thin material.
4. Screw specification as above or equivalent fastener.
5. RippleZips® screws are not available in Class 4 coating.

Valley: 6 fasteners †



Valley: 11 fasteners †



† Number of fasteners per sheet per support depends on wind pressure.

PANELRIB®

PANELRIB® is a lightly fluted wall cladding or ceiling for exterior and interior use, on straight or curved surfaces.

Longitudinal flutes provide rigidity along the length of the sheet while retaining full flexibility across the width.

Used on interior or exterior walls on straight or curves surfaces for walling in garages, ceilings, fascia and barge boards.

For aesthetic reasons, end-laps are not recommended.

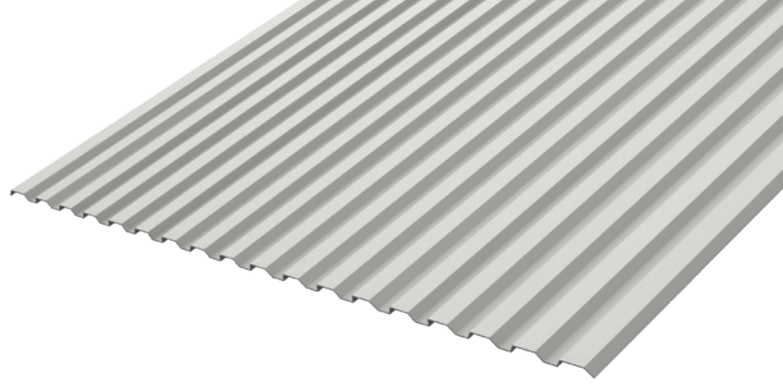

MASSSES

	BMT (mm)	kg/m ²
ZINCALUME® steel	0.35	3.19
COLORBOND® steel	0.35	3.22
ZINCALUME® steel	0.42	3.80
COLORBOND® steel	0.42	3.83



SHEET COVERAGE

Width of Wall (m)	3	4	5	6	7	8	9	10	11	12	13	14	15	16	17	18	19	20	30	40	50
Number of Sheets	4	5	6	8	9	10	11	12	13	15	16	17	18	19	20	22	23	24	36	48	59

PANELRIB® LIMIT STATE WIND PRESSURE CAPACITIES (KPA) 0.35 BMT

Span Type	Fasteners per sheet per support	Limit State	Span (mm)									
			600	700	800	900	1000	1100	1200	1300	1400	1500
Single	4	Serviceability	2.11	1.74	1.39	1.06	0.76	0.51	0.31	0.18	-	-
		Strength	9.45	8.55	7.65	6.85	6.10	5.40	4.85	4.40	-	-
	8	Serviceability	2.01	1.67	1.34	1.03	0.75	0.52	0.33	0.20	-	-
		Strength	12.00	12.00	12.00	12.00	10.80	9.70	8.80	8.10	-	-
End	4	Serviceability	3.39	2.80	2.22	1.68	1.19	0.78	0.45	0.23	-	-
		Strength	7.35	6.60	5.85	5.15	4.50	3.90	3.40	3.00	-	-
	8	Serviceability	2.78	2.29	1.82	1.38	0.98	0.64	0.37	0.19	-	-
		Strength	11.25	10.20	9.25	8.30	7.45	6.65	6.00	5.45	-	-
Internal	4	Serviceability	3.95	3.32	2.71	2.13	1.61	1.15	0.78	0.51	0.32	0.19
		Strength	8.25	7.45	6.60	5.95	5.30	4.70	4.20	3.80	3.55	3.35
	8	Serviceability	3.63	3.02	2.44	1.88	1.38	0.95	0.60	0.35	0.19	0.10
		Strength	12.00	12.00	12.00	11.00	9.85	8.85	8.00	7.30	6.75	6.35

PANELRIB® LIMIT STATE WIND PRESSURE CAPACITIES (KPA) 0.42 BMT

Span Type	Fasteners per sheet per support	Limit State	Span (mm)									
			600	700	800	900	1000	1100	1200	1300	1400	1500
Single	4	Serviceability	2.18	1.82	1.48	1.15	0.86	0.61	0.41	0.27	0.18	0.13
		Strength	12.00	12.00	12.00	11.15	10.00	8.95	8.10	7.30	6.70	6.15
	8	Serviceability	1.92	1.63	1.34	1.07	0.82	0.61	0.44	0.32	0.23	0.17
		Strength	12.00	12.00	12.00	12.00	12.00	11.65	10.80	10.15	9.65	9.30
End	4	Serviceability	3.60	3.00	2.42	1.87	1.38	0.95	0.61	0.37	0.21	0.12
		Strength	8.25	7.50	6.75	6.05	5.40	4.80	4.30	3.90	3.55	3.25
	8	Serviceability	2.90	2.37	1.86	1.38	0.95	0.59	0.31	0.12	-	-
		Strength	12.00	12.00	12.00	12.00	10.90	9.70	8.70	7.90	-	-
Internal	4	Serviceability	6.21	5.09	4.01	3.00	2.09	1.32	0.73	0.33	0.10	-
		Strength	10.35	9.35	8.40	7.50	6.70	5.95	5.40	4.90	4.60	4.35
	8	Serviceability	4.60	3.79	3.00	2.27	1.61	1.05	0.61	0.32	0.14	0.07
		Strength	12.00	12.00	12.00	12.00	12.00	11.35	10.35	9.50	8.90	8.40

Refer to notes on Limit State Wind Pressure on page 2 of this brochure.

PANELRIB® INSTALLATION

FASTENERS WITHOUT INSULATION

	Fix to Steel Single & lapped steel thickness ≥0.55 up to 1.0mm BMT	Fix to Steel Single steel thickness ≥1.0mm BMT up to 3.0mm BMT	Fix to Steel Total lapped thickness ≥1.00 BMT up to 3.8mm BMT	Fix to Timber Hardwood J1-J3	Fix to Timber Softwood J4
Pan Fixed	10-16x16, Metal Tek's, HH or 10-16x25 Designer Head or Roof Zips M6-11x25	10-16x16, Metal Tek's, HH or 10-16x25 Designer Head	10-16x16, Metal Tek's, HH	10-12x25, Type 17, HH or 10-16x25 Designer Head	10-12x30, Type 17, HH or 10-16x25 Designer Head or Roof Zips M6-11x25
Side-laps	Sealed blind rivet ø3.2mm aluminium (if required)				

Notes:

1. For other steel thicknesses not specified please seek advice from screw manufacturer.
2. Values given are: gauge/threads per inch/ lengths (mm). HH = Hex. Head, WH = Wafer Head, HG = Hi-Grip
3. Care is required during installation to prevent stripping of thin material. (Single ply.)
4. Screw specification as above or equivalent fastener.
5. All screws with EPDM sealing washer.

SIDE-LAPPING OPTIONS FOR PANELRIB®

A fastener should be located at the side-lap. For a quality finish, fasteners at the ends of PANELRIB® sheets, including end-laps, should be located at every second valley. At intermediate supports, a minimum of four fasteners should be used equidistant across the sheet.

For internal applications not subject to wind loads, the number of fasteners may be reduced to suit the project's aesthetic requirements, however not less than 50%. Furthermore, the lap can be located to achieve a 900mm cover, except for ceiling applications.

SIDE-LAPPING

Two types of side-lapping methods are used: the overlapping flute, and the edge lap joint. (See illustrations above.)

The side-lap requires fasteners at 200-300mm centres between supports.

TRIMS

Refer to Page 5 for range of wall trims. Contact your local Lysaght representative for availability.

Pan: 4 fasteners †



Pan: 8 fasteners †

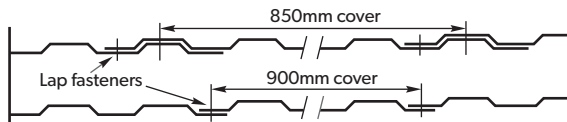

Alternative lapping to achieve a 900mm cover in internal applications.

SPANDEK®

SPANDEK® is a contemporary-looking trapezoidal profile which is ideal where a stronger, bolder more modern corrugated appearance is required.

SPANDEK® combines strength with lightness, rigidity and economy.

The long, straight lengths of SPANDEK® can be lifted into place and easily aligned.

Originally designed as a strong attractive roofing material for industrial and commercial construction—however SPANDEK® has proved equally popular for homes and public buildings, as walling underlining its versatility and pleasing appearance.

User to specify wall use when ordering.

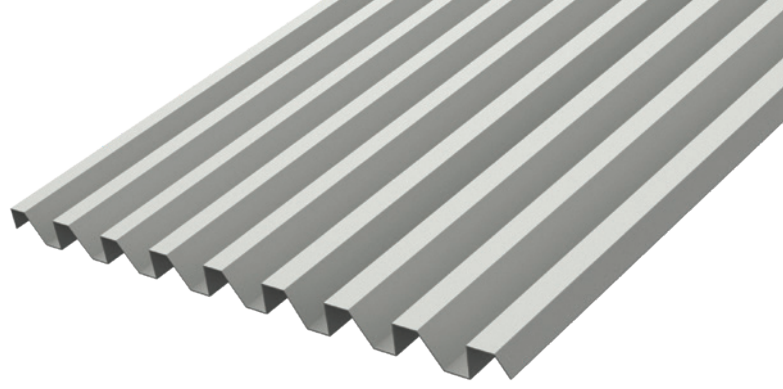

MASSES

	BMT (mm)	kg/m ²
ZINCALUME® steel	0.42	4.61
COLORBOND® steel	0.42	4.65
ZINCALUME® steel	0.48	5.24
COLORBOND® steel	0.48	5.28

SHEET COVERAGE

Width of Wall (m)	3	4	5	6	7	8	9	10	11	12	13	14	15	16	17	18	19	20	30	40	50
Number of Sheets	5	6	8	9	10	12	13	15	16	18	19	20	22	23	25	26	28	29	43	58	72

SPANDEK® LIMIT STATE WIND PRESSURE CAPACITIES (KPA) 0.42 BMT

Span Type	Fasteners per sheet per support	Limit State	Span (mm)								
			900	1200	1500	1800	2100	2400	2700	3000	3300
Single	3	Serviceability	2.04	1.64	1.27	0.96	0.72	0.54	0.41	0.30	-
		Strength	8.35	6.85	5.45	4.30	3.50	2.95	2.60	2.30	-
	4	Serviceability	4.24	3.07	2.02	1.20	0.68	0.42	0.33	0.30	-
		Strength	10.25	8.35	6.60	5.20	4.25	3.70	3.40	3.20	-
End	3	Serviceability	2.05	1.82	1.61	1.40	1.20	1.02	0.83	0.65	-
		Strength	5.85	4.40	3.20	2.35	1.85	1.55	1.45	1.40	-
	4	Serviceability	3.75	3.19	2.67	2.20	1.78	1.40	1.05	0.72	-
		Strength	6.90	5.65	4.55	3.75	3.15	2.70	2.40	2.20	-
Internal	3	Serviceability	1.96	1.81	1.66	1.52	1.37	1.23	1.08	0.93	0.79
		Strength	6.90	5.80	4.70	3.70	2.85	2.25	1.80	1.60	1.50
	4	Serviceability	4.74	4.05	3.38	2.75	2.20	1.73	1.36	1.08	0.87
		Strength	8.55	6.80	5.40	4.35	3.55	2.95	2.55	2.30	2.20

SPANDEK® LIMIT STATE WIND PRESSURE CAPACITIES (KPA) 0.48 BMT

Span Type	Fasteners per sheet per support	Limit State	Span (mm)								
			900	1200	1500	1800	2100	2400	2700	3000	3300
Single	3	Serviceability	2.50	2.08	1.69	1.34	1.04	0.79	0.58	0.38	-
		Strength	9.00	7.55	6.25	5.10	4.25	3.60	3.10	2.70	-
	4	Serviceability	5.07	3.53	2.35	1.48	1.00	0.70	0.52	0.40	-
		Strength	12.00	10.35	8.30	6.65	5.40	4.60	4.00	3.60	-
End	3	Serviceability	3.05	2.58	2.15	1.78	1.47	1.20	0.96	0.75	-
		Strength	7.55	5.65	4.05	3.35	2.85	2.50	2.25	2.10	-
	4	Serviceability	5.34	4.37	3.50	2.76	2.16	1.65	1.22	0.83	-
		Strength	9.75	7.65	5.85	4.50	3.70	3.20	2.95	2.85	-
Internal	3	Serviceability	2.72	2.40	2.09	1.79	1.53	1.30	1.10	0.95	0.82
		Strength	9.00	7.05	5.50	4.30	3.40	2.75	2.35	2.10	2.00
	4	Serviceability	6.50	5.44	4.43	3.49	2.66	1.99	1.49	1.14	0.90
		Strength	11.40	9.70	8.05	6.55	5.25	4.20	3.50	3.05	2.80

Refer to notes on Limit State Wind Pressure on page 2 of this brochure.

SPANDEK® INSTALLATION

FASTENERS WITHOUT INSULATION

	Fix to Steel Single & lapped steel thickness ≥0.55 up to 1.0mm BMT	Fix to Steel Single steel thickness ≥1.0mm BMT up to 3.0mm BMT	Fix to Steel Total lapped thickness ≥1.00 BMT up to 3.8mm BMT	Fix to Timber Hardwood J1-J3	Fix to Timber Softwood J4
Crest Fixed	Roof Zips M6-11x50	12-14x45, Metal Tek's HG, HH or AutoTek's M5.5-14x50	12-14x45, Metal Tek's HG, HH or AutoTek's M5.5-14x50	12-11x65, Type 17 HG, HH	12-11x65, Type 17 HG, HH or Roof Zips M6-11x65
Pan Fixed	10-16x16, Metal Tek's, HH or M5-16x25 Designer Head or Roof Zips M6-11x25	10-16x16, Metal Tek's, HH or M5-16x25 Designer Head	10-16x16, Metal Tek's, HH	10-12x25, Type 17, HH or M5-16x25 Designer Head	10-12x30, Type 17, HH or M5-16x25 Designer Head or Roof Zips M6-11x25
Side-laps	(If required) 10-16x16, Metal Tek's, HH or Roof Zips M6-11x25 or M5-16x25 Designer Head or Sealed blind rivet ø4.8mm aluminium				

Notes:

1. For other steel thicknesses not specified please seek advice from screw manufacturer.
2. Values given are: gauge/threads per inch/lengths (mm). HH = Hex. Head, WH = Wafer Head, HG = Hi-Grip
3. Care is required during installation to prevent stripping of thin material. (Single ply.)
4. Screw specification as above or equivalent fastener.
5. All screws with EPDM sealing washer.

FASTENING SHEETS TO SUPPORTS

SPANDEK® is pierce-fixed to timber or steel supports. This means that fastener screws pass through the sheeting.

You can place screws for SPANDEK® through the crests or in the valleys. For walling, valley-fixing is the standard industry practice.

Always drive the screws perpendicular to the sheeting, and in the centre of the corrugation or rib.

Don't place fasteners less than 25mm from the ends of sheets.

SIDE-LAPS

The edge of SPANDEK® with the anti-capillary groove is always the underlap (see figures on this page). It is generally considered good practice to use fasteners along side-laps however, when cladding is supported as indicated in Maximum Support Spacings, side-lap fasteners are not usually needed when crest fixed. When valley-fixed, the cladding needs a side-lap fastener in all laps, at each support.

END-LAPPING

End-laps are not usually necessary because SPANDEK® is available in long lengths.

If you want end-laps, refer to the LYSAGHT® Roofing and Walling Installation Manual.

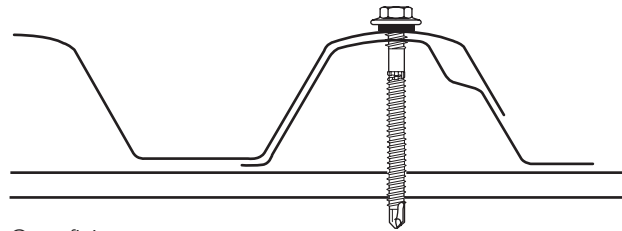

Crest fixing

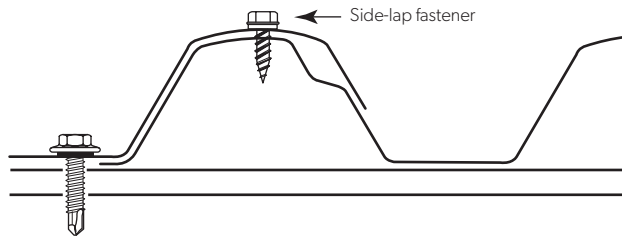

Valley fixing

Crest: 3 fasteners †



Valley: 3 fasteners †



Crest: 4 fasteners †



Valley: 4 fasteners †



† Fasteners per sheet per support. Most common practice is: 3 fasteners for internal spans and 4 fasteners for single and end supports.

TRIMDEK®

TRIMDEK® is a stylish, ribbed profile with subtle fluting in the pans to provide strength and long spanning capabilities.

Strong, durable, versatile roof and wall cladding available in long lengths so one sheet may be used from eaves to floor without end-laps.

The strength, spanning ability, lightness and rigidity of TRIMDEK® profile permits wide support spacings to be used with safety.

Long, straight lengths of TRIMDEK® can be easily aligned.

Equally suitable for domestic, industrial and commercial applications.



MASSES

	BMT (mm)	kg/m ²
ZINCALUME® steel	0.42	4.23
COLORBOND® steel	0.42	4.27
ZINCALUME® steel	0.48	4.81
COLORBOND® steel	0.48	4.85

SHEET COVERAGE

Width of Wall (m)	3	4	5	6	7	8	9	10	11	12	13	14	15	16	17	18	19	20	30	40	50
Number of Sheets	4	6	7	8	10	11	12	14	15	16	18	19	20	21	23	24	25	27	40	53	66

TRIMDEK® LIMIT STATE WIND PRESSURE CAPACITIES (KPA) 0.42 BMT

Span Type	Limit State	Span (mm)								
		600	900	1200	1500	1800	2100	2400	2700	3000
Single	Serviceability	4.98	3.91	2.83	1.87	1.16	0.75	0.53		
	Strength	10.25	8.35	6.45	4.75	3.60	3.00	2.75		
End	Serviceability	4.18	3.63	3.08	2.55	2.06	1.62	1.22	0.85	0.50
	Strength	6.35	5.85	5.30	4.80	4.30	3.80	3.25	2.75	2.25
Internal	Serviceability	5.05	4.18	3.42	2.83	2.36	1.94	1.56	1.23	0.97
	Strength	9.50	7.95	6.55	5.25	4.30	3.65	3.30	3.05	2.85

TRIMDEK® LIMIT STATE WIND PRESSURE CAPACITIES (KPA) 0.48 BMT

Span Type	Limit State	Span (mm)								
		600	900	1200	1500	1800	2100	2400	2700	3000
Single	Serviceability	7.27	5.06	3.34	2.06	1.15	0.71	0.50	0.42	
	Strength	12.00	11.60	9.60	7.75	6.10	4.75	3.60	2.65	
End	Serviceability	6.29	5.13	3.96	2.93	2.13	1.54	1.12	0.82	0.58
	Strength	9.40	8.00	6.55	5.30	4.35	3.65	3.25	2.95	2.75
Internal	Serviceability	7.37	5.96	4.66	3.54	2.72	2.22	1.92	1.64	1.38
	Strength	9.90	8.55	7.35	6.25	5.40	4.75	4.30	3.85	3.45

Refer to notes on Limit State Wind Pressure on page 2 of this brochure.

TRIMDEK® INSTALLATION

FASTENERS WITHOUT INSULATION

	Fix to Steel Single & lapped steel thickness ≥0.55 up to 1.0mm BMT	Fix to Steel Single steel thickness ≥1.0mm BMT up to 3.0mm BMT	Fix to Steel Total lapped thickness ≥1.00 BMT up to 3.8mm BMT	Fix to Timber Hardwood J1-J3	Fix to Timber Softwood J4
Crest Fixed	Roof Zips M6-11x50	12-14x45, Metal Tekes HG, HH or AutoTekes M5.5-14x50	12-14x45, Metal Tekes HG, HH or AutoTekes M5.5-14x50	12-11x65, Type 17 HG, HH	12-11x65, Type 17 HG, HH or Roof Zips M6-11x65
Pan Fixed	10-16x16, Metal Tekes, HH or M5-16x25 Designer Head or Roof Zips M6-11x25	10-16x16, Metal Tekes, HH or M5-16x25 Designer Head	10-16x16, Metal Tekes, HH	10-12x25, Type 17, HH or M5-16x25 Designer Head	10-12x30, Type 17, HH or M5-16x25 Designer Head or Roof Zips M6-11x25
Side-laps	(If required) 10-16x16, Metal Tekes, HH or Roof Zips M6-11x25 or M5-16x25 Designer Head or Sealed blind rivet ø4.8mm aluminium				

Notes:

1. For other steel thicknesses not specified please seek advice from screw manufacturer.
2. Values given are: gauge/threads per inch/lengths (mm). HH = Hex. Head, WH = Wafer Head, HG = Hi-Grip
3. Care is required during installation to prevent stripping of thin material. (Single ply.)
4. Screw specification as above or equivalent fastener.
5. All screws with EPDM sealing washer.

FASTENING SHEETS TO SUPPORTS

TRIMDEK® profile is pierce-fixed to timber or steel supports. This means that fastener screws pass through the sheeting.

You can place screws for TRIMDEK® through the crests or in the pans. For walling, pan-fixing is standard industry practice.

Always drive the screws perpendicular to the sheeting, and in the centre of the rib, or on the flat section of the pan beside each rib when valley fixed. Don't place fasteners less than 25mm from the ends of sheets.

SIDE-LAPS

The edge of TRIMDEK® with the anti-capillary groove is always the underlap (see figures on this page). It is generally considered good practice to use fasteners along side-laps however, when cladding is supported as indicated in Maximum Support Spacings, side-lap fasteners are not usually needed when crest fixed. When valley-fixed, the cladding needs a side-lap fastener in all laps, at each support.

END-LAPPING

End-laps are not usually necessary because TRIMDEK® is available in long lengths.

If you want end-laps, refer to the LYSAGHT® Roofing and Walling Installation Manual.



Crest fixing

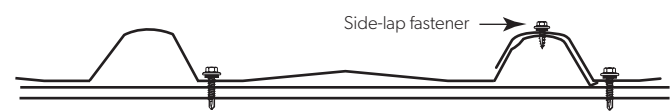

Pan fixing

Crest fixing: 4 fasteners †

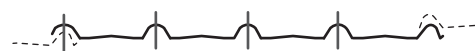

Pan fixing: 4 fasteners †



† Fasteners per sheet per support.

TRIMWALL®

TRIMWALL® has trapezoidal ribs and pans that match TRIMDEK®. It is used for walls, primarily on sheds.

The strength, spanning ability, lightness and rigidity of TRIMDEK® profile permits wide support spacings to be used with safety.

Long, straight lengths of TRIMDEK® can be lowered into place and easily aligned. Equally suitable for domestic, industrial and commercial applications.

Sheet coverage is the same as that of TRIMDEK®. Refer to TRIMDEK® in this brochure for valley fix installation details.

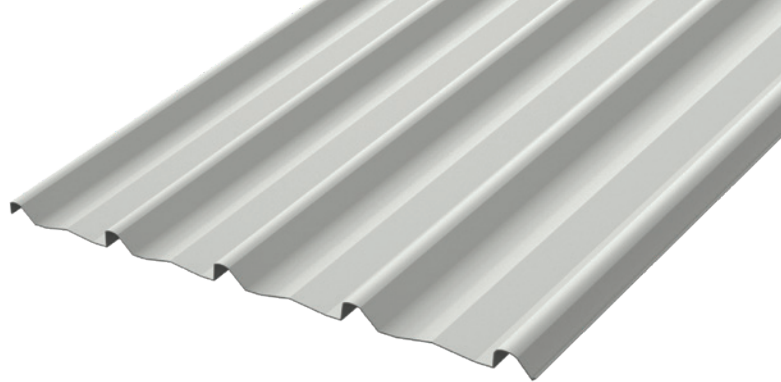

MASSES

	BMT (mm)	kg/m ²
ZINCALUME® steel	0.35	3.56
COLORBOND® steel	0.35	3.60

SHEET COVERAGE

Width of Wall (m)	3	4	5	6	7	8	9	10	11	12	13	14	15	16	17	18	19	20	30	40	50
Number of Sheets	4	6	7	8	10	11	12	14	15	16	18	19	20	21	23	24	25	27	40	53	66

TRIMWALL® LIMIT STATE WIND PRESSURE CAPACITIES (KPA) 0.35 BMT

Span Type	Limit State	Span (mm)									
		600	900	1200	1500	1800	2100	2400	2700	3000	3300
Single	Serviceability	2.81	2.28	1.80	1.39	1.05	0.75	0.48	-	-	-
	Strength	6.65	4.60	3.05	2.30	1.85	1.55	1.35	-	-	-
End	Serviceability	2.78	2.77	2.76	2.47	1.93	1.31	0.80	0.51	0.40	0.39
	Strength	5.90	5.35	4.75	4.00	3.15	2.40	1.85	1.60	1.50	1.45
Internal	Serviceability	2.83	2.73	2.57	2.30	1.96	1.58	1.23	0.92	0.65	0.40
	Strength	6.75	6.30	5.75	4.90	3.90	2.95	2.25	1.80	1.60	1.55

Refer to notes on Limit State Wind Pressure on page 2 of this brochure.

FASTENERS WITHOUT INSULATION

	Fix to Steel Single & lapped steel thickness ≥0.55 up to 1.0mm BMT	Fix to Steel Single steel thickness ≥1.0mm BMT up to 3.0mm BMT	Fix to Steel Total lapped thickness ≥1.00 BMT up to 3.8mm BMT	Fix to Timber Hardwood J1-J3	Fix to Timber Softwood J4
Pan Fixed	10-16x16, Metal Tek's, HH or M5-16x25 Designer Head or Roof Zips M6-11x25	10-16x16, Metal Tek's, HH or M5-16x25 Designer Head	10-16x16, Metal Tek's, HH	10-12x25, Type 17, HH or M5-16x25 Designer Head	10-12x30, Type 17, HH or M5-16x25 Designer Head or Roof Zips M6-11x25
Side-laps	10-16x16, Metal Tek's, HH or Roof Zips M6-11x25 or M5-16x25 Designer Head or Sealed blind rivet ø4.8mm aluminium				

Notes:

- For other steel thicknesses not specified please seek advice from screw manufacturer.
- Values given are: gauge/threads per inch/lengths (mm). HH = Hex. Head, WH = Wafer Head, HG = Hi-Grip
- Care is required during installation to prevent stripping of thin material. (Single ply.)
- Screw specification as above or equivalent fastener.
- All screws with EPDM sealing washer.

Pan: 4 fasteners †



† Fasteners per sheet per support.

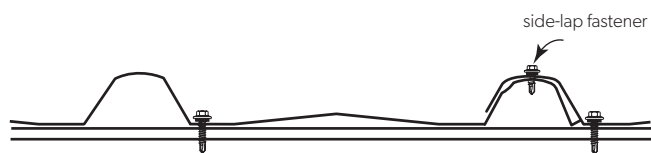

Pan fixing

WALLCLAD™

(QLD, SA & WA ONLY)

WALLCLAD™ is an attractive, lightweight and versatile walling profile designed for domestic, rural and commercial applications. It is light and easy to handle and quick to install.

WALLCLAD™ is popular in the residential market where a traditional profile can be used to add a contemporary character.

Ideal for garages, sheds, fascias and awning linings. WALLCLAD™ is identical to the CUSTOM ORB® profile but is 0.35mm BMT and is exclusively used for economic walling applications.

Refer to the CUSTOM ORB® valley installation details in this brochure for installation details.

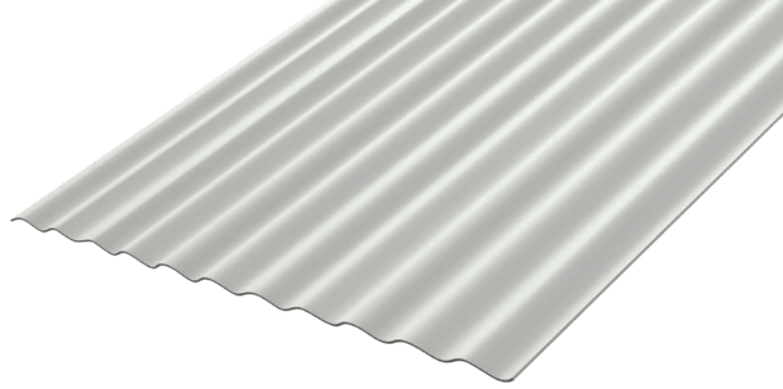

MASSES

	BMT (mm)	kg/m ²
ZINCALUME® steel	0.35	3.56
COLORBOND® steel	0.35	3.60

SHEET COVERAGE

Width of Wall (m)	3	4	5	6	7	8	9	10	11	12	13	14	15	16	17	18	19	20	30	40	50
Number of Sheets	4	6	7	8	10	11	12	14	15	16	18	19	20	21	23	24	25	27	40	53	66

WALLCLAD™ LIMIT STATE WIND PRESSURE CAPACITIES (KPA) 0.35 BMT

Span Type	Fasteners per sheet per support	Limit State	Span (mm)						
			600	900	1200	1500	1800	2100	2400
Single	3	Serviceability	1.32	1.21	1.07	0.87	0.65	0.41	0.17
		Strength	10.85	8.40	6.35	5.15	4.20	3.40	2.70
	5	Serviceability	5.00	3.16	1.72	1.06	0.63	0.36	0.17
		Strength	12.00	12.00	10.60	8.90	7.30	5.80	4.30
End	3	Serviceability	1.32	1.29	1.23	1.12	0.93	0.68	0.41
		Strength	9.00	6.60	4.50	2.95	2.05	1.70	1.60
	5	Serviceability	6.55	4.64	2.93	1.64	0.90	0.58	0.46
		Strength	12.00	12.00	7.30	5.20	3.85	3.10	2.70
Internal	3	Serviceability	1.33	1.32	1.31	1.28	1.16	1.00	0.82
		Strength	9.60	7.30	5.40	4.20	3.30	2.50	1.80
	5	Serviceability	6.38	4.83	3.48	2.46	1.72	1.15	0.64
		Strength	12.00	10.90	8.55	6.85	5.40	4.05	2.80

Refer to notes on Limit State Wind Pressure on page 2 of this brochure.

FASTENERS WITHOUT INSULATION

	Fix to Steel Single & lapped steel thickness ≥0.55 up to 1.0mm BMT	Fix to Steel Single steel thickness ≥1.0mm BMT up to 3.0mm BMT	Fix to Steel Total lapped thickness ≥1.00 BMT up to 3.8mm BMT	Fix to Timber Hardwood J1-J3	Fix to Timber Softwood J4
Valley Fixed	10-16x16, Metal Tekes, HH or M5-16x25 Designer Head or Roof Zips M6-11x25	10-16x16, Metal Tekes, HH or M5-16x25 Designer Head	10-16x16, Metal Tekes, HH	10-12x25, Type 17, HH or M5-16x25 Designer Head	10-12x30, Type 17, HH or M5-16x25 Designer Head or Roof Zips M6-11x25
Side-laps	10-16x16, Metal Tekes, HH or Roof Zips M6-11x25 or M5-16x25 Designer Head or Sealed blind rivet ø4.8mm				

Notes:

- For other steel thicknesses not specified please seek advice from screw manufacturer.
- Values given are: gauge/threads per inch/lengths (mm). HH = Hex. Head, WH = Wafer Head, HG = Hi-Grip
- Care is required during installation to prevent stripping of thin material. (Single ply.)
- Screw specification as above or equivalent fastener.
- All screws with EPDM sealing washer.

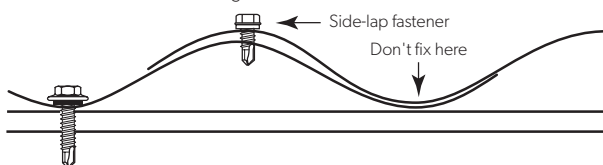

Valley fixing



† Number of fasteners per sheet per support. Most common practise is 3 fasteners for internal spans and 5 fasteners for single and end supports.

PRODUCT DESCRIPTIONS

- All descriptions, specifications, illustrations, drawings, data, dimensions, and weights contained in this publication and websites containing information from Lysaght are approximations only. They are intended by Lysaght to be a general description for information and identification purposes and do not create a sale by description. Lysaght reserves the right at any time to:

(a) Supply goods with such minor modifications from its drawings and specifications as it sees fit, and

b) Alter specifications shown in its publications and websites to reflect changes made after the date of publication.

DISCLAIMER, WARRANTIES AND LIMITATION OF LIABILITY

- This publication is intended to be an aid for all trades and professionals involved with specifying and installing LYSAGHT® products and not be a substitute for professional judgement.
- Terms and conditions of sale are available at lysaght.com/terms
- Except to the extent to which liability may not lawfully be excluded or limited, BlueScope Steel Limited will not be under or incur any liability to you for any direct or indirect loss or damage (including, without limitation, consequential loss or damage such as loss of profit or anticipated profit, loss of use, damage to goodwill and loss due to delay) however caused (including, without limitation, breach of contract, negligence and/or breach of statute), which you may suffer or incur in connection with this publication.

AUSTRALIAN STANDARDS

Australian Standard	Definition
AS 1397:2021	Continuous hot-dip metallic coated steel sheet and strip — Coatings of zinc and zinc alloyed with aluminium and magnesium
AS/NZS 2728:2013	Prefinished/pre-painted sheet metal products for interior/exterior building applications — Performance requirements
AS 1562.1:2018	Design and installation of metal roof and wall cladding, Part 1: Metal
AS 4040.1-1992 (Reconfirmed 2016)	Methods of testing sheet roof and wall cladding - Method 1: Resistance to concentrated loads
AS 4040.2-1992 (Reconfirmed 2016, Amendment 1:2018)	Methods of testing sheet roof and wall cladding, Part 2: Resistance to wind pressures for non-cyclone regions
AS 1562.1:2018	Design and installation of metal roof and wall cladding, Part 1: Metal
AS/NZS 1170.2:2021	Structural design actions, Part 2: Wind actions

FOR DETAILED PRODUCT INFORMATION,
MANUALS AND PROJECT CASE STUDIES VISIT:

[WWW.LYSAGHT.COM](https://www.lysaght.com)

Thermatech® solar reflectance technology is not available in Night Sky®, or non-standard colours, and is not available in SUPERDURA® Stainless steel, COLORBOND® Metallic steel, or COLORBOND® Coolmax® steel.

COLORBOND®, SUPERDURA®, ZINCALUME®, Thermatech®, LYSAGHT® and © product names are registered trademarks of BlueScope Steel Limited and ™ product names are trademarks of BlueScope Steel Limited. © 2024 BlueScope Steel Limited. ABN 16 000 011 058. All rights reserved.

INSPIRATION TO BUILD BETTER

