

Topdek® 700

 STRATCO





Innovative, stylish, strong and flexible, Topdek 700 is an exceptional cladding.



FORM AND FUNCTION

Utilising an ingenious concealed clip, Topdek® 700 benefits from a strong, clean finish without any visible fixings. It allows for thermal expansion and contraction, making it ideal for long length roofing in both domestic and commercial uses. The profile of Topdek 700 consists of strong, 42mm high, trapezoidal shaped ribs that provide strength and rigidity. Less purlins are needed thanks to the high rib height. Wide deep pans channel water efficiently from the roof making Topdek 700 excellent for areas of high rainfall. Topdek 700 can be installed on roofs with pitches as low as one degree.

Designed to lock together, each Topdek 700 sheet has a male and a female edge that forms a strong locking action when joined together. The anti-capillary shape of the female rib means water is stopped from entering through the side-laps. The sheets lock into the specially designed Topdek 700 clips. The clips are fastened to the purlins with hex head screws (table 8.0) through the holes provided. Although the clips join the roof deck to the purlins, they still allow for expansion and contraction, which is important for long length roofing.

CUSTOM MADE FOR YOUR PROJECT

For lengths over 1.2 metres, Topdek 700 can be rolled to the length you require, provided the appropriate transport and handling can be arranged. For lengths longer than ten metres, contact your nearest Stratco for advice on handling and transport. Stratco offer a complete range of flashings and accessories for use with Topdek 700, and can provide professional advice on specific flashings.

DESIGN CONSIDERATIONS

The minimum recommended roof pitch for Topdek 700 is one degree (1 in 60). The 700mm coverage of Topdek 700 provides easy handling and installation. Topdek 700 roofing is subject to thermal expansion, particularly on darker colours. The maximum length before an expansion joint is required is 24 metres for lighter colours, and 16 metres for darker colours.

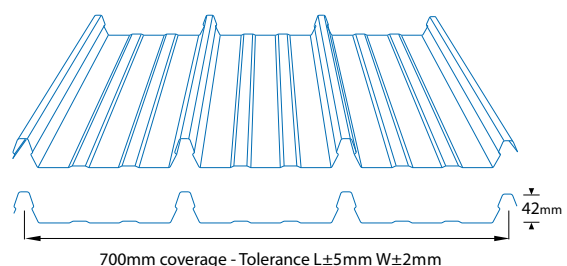

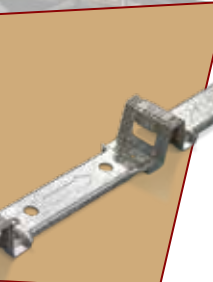

MATERIAL SPECIFICATIONS

Material Properties	Finish	0.42 BMT	0.48 BMT
Total Coated Thickness (TCT) mm	Zinc/alum	0.47	0.53
	Colour	0.50	0.56
Mass (kg/linear metre)	Zinc/alum	3.26	3.70
	Colour	3.32	3.76
Mass (kg/square metre)	Zinc/alum	4.66	5.28
	Colour	4.74	5.37
Yield (square metre/tonne)	Zinc/alum	214.6	189.4
	Colour	211.0	186.2
Tensile Strength (MPa)	Zinc/alum & Colour	550	550
Width Coverage (mm)	Zinc/alum & Colour	700	700
Sheet Tolerances (mm)	Length & Width	±5	±5
Minimum Roof Pitch	Zinc/alum & Colour	1°	1°

Table 1.0

COMPLIANCE

The Wind Capacity Tables are based on testing in accordance with AS1562.1-1992 and AS4040.0, 1 & 2-1992. Span tables have been developed by determining wind pressures in accordance with AS4055-2006 for domestic applications and AS/NZS 1170.2:2002 for all other applications. Capacity tables are in limit state format.

SPANS

Spans are determined by wind speeds for non-cyclonic areas. For domestic applications, the pressures and spans are based on a maximum: eaves height of six metres, roof pitch of 35 degrees and total roof height of 8.5 metres. For commercial and industrial applications, tables are based on a maximum overall height of ten metres and a 500 year design return period.

Roofing calculations are based on $C_{pe} = -0.9$ and $C_{pi} = 0.2$, walling is based on $C_{pe} = -0.65$ and $C_{pi} = 0.2$. A local pressure factor, $K_l = 2.0$ has been used for all roofing and walling spans for both strength and serviceability limit states. Roof spans allow for loads incidental to maintenance.

All pressures have been determined assuming the wind loading in any direction is not affected by topography. The following shielding factors have been used for each of the terrain categories: Category 3 = 0.85, Category 2.5 = 0.95, and Category 2 = 1.

The carport and verandah spans only apply to structures not enclosed by peripheral walls. Spans are based on $C_{pn} = -0.9$ and $K_l = 1.5$ applied over the entire span, and are suitable for all span types. Loads on supporting purlins may limit these spans.

Stratco can provide additional engineering advice if any design parameters vary from those above.

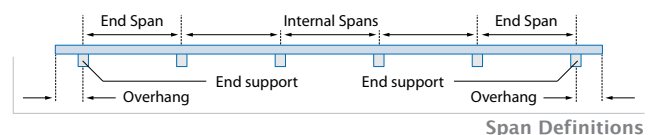

Wind Load Conversion

For domestic applications use the appropriate wind classification for the area. To read the span tables for commercial and industrial applications, select the region and category for the area, then convert it to the correct classification using table 2.0 below.

WIND LOAD CONVERSION

Wind Classification (Domestic)	Region & Category (Commercial/Industrial)
N1 (W28)	Reg A, Cat 3
N2 (W33)	Reg A, Cat 2.5 - Reg B, Cat 3
N3 (W41)	Reg A, Cat 2 - Reg B, Cat 2.5
N4 (W50)	Reg B, Cat 2

Table 2.0



MAXIMUM RECOMMENDED SPANS (mm)

Span Type	Roofing (BMT)		Walling (BMT)	
	0.42mm	0.48mm	0.42mm	0.48mm
Single Span	2000	2200	2850	3000
End Span	2200	2950	3000	3250
Internal Span	2300	3100	3200	3600
Un-stiffened Overhang	200	200	300	300
Stiffened Overhang	600	600	400	400

Roofing spans are limited, based on typical maintenance foot traffic. Walling spans are based on N1 (W28) wind loading. All spans are based on three fasteners per clip, per support.

Table 3.0

DOMESTIC CARPORT/VERANDAH SPANS

Wind Classification	Base Metal Thickness	
	0.42mm	0.48mm
N1 (W28)	3800mm	4200mm
N2 (W33)	3800mm	4200mm
N3 (W41)	2300mm	2600mm
N4 (W50)	1500mm	1750mm

Spans are not based on fixing to clips, but on pierce fixing with two fasteners per pan, per support.

Table 4.0

SPANS (mm)

BMT	Application	Span Type	THREE SCREWS PER CLIP				FIVE SCREWS PER CLIP			
			N1 (W28)	N2 (W33)	N3 (W41)	N4 (W50)	N1 (W28)	N2 (W33)	N3 (W41)	N4 (W50)
0.42mm	Roofing	Single	2000	1750	1250	-	2000	1900	1500	-
		End	2200	2100	1550	-	2200	2200	1750	1300
		Internal	2300	2300	1650	-	2300	2300	2050	1550
	Walling	Single	2850	2050	1750	900	2850	2250	1900	1200
		End	3000	2400	1950	1350	3200	2650	2250	1850
		Internal	3200	2900	2250	1650	3600	3100	2550	2150
0.48mm	Roofing	Single	2200	1900	1600	-	2200	1900	1600	-
		End	2950	2300	2000	1300	2950	2300	2050	1550
		Internal	3100	2850	2300	1400	3100	2950	2400	2000
	Walling	Single	3000	2300	1900	1250	3000	2250	1900	1450
		End	3250	2750	2300	1800	3600	2850	2300	2050
		Internal	3600	3250	2850	2100	3600	3350	2950	2550

Table 5.0

WIND CAPACITIES (kPa)

BMT	Span Type	Limit State	SPAN (mm) – THREE FASTENERS									SPAN (mm) – FIVE FASTENERS										
			900	1200	1500	1800	2100	2400	2700	3000	3300	3600	900	1200	1500	1800	2100	2400	2700	3000	3300	3600
0.42mm	Single	Serviceability	2.14	1.83	1.53	1.22	0.92	0.82	0.72	0.63	-	-	2.45	2.12	1.78	1.45	1.11	0.91	0.71	0.51	-	-
		Strength	3.40	3.06	2.72	2.38	2.04	1.73	1.43	1.12	-	-	3.73	3.38	3.02	2.67	2.32	1.91	1.51	1.11	-	-
	End	Serviceability	2.47	2.19	1.90	1.62	1.33	1.05	0.87	0.70	0.53	0.35	2.42	2.15	1.89	1.63	1.36	1.10	0.92	0.75	0.57	0.39
		Strength	4.22	3.67	3.12	2.57	2.02	1.48	1.28	1.08	0.88	0.68	5.33	4.72	4.11	3.49	2.88	2.27	2.05	1.83	1.60	1.38
	Internal	Serviceability	2.13	1.94	1.76	1.57	1.39	1.20	1.05	0.90	0.75	0.60	2.64	2.38	2.12	1.86	1.60	1.34	1.17	1.00	0.84	0.67
		Strength	4.74	4.19	3.65	3.10	2.55	2.00	1.69	1.39	1.08	0.78	5.63	5.10	4.58	4.05	3.52	2.99	2.62	2.25	1.88	1.52
0.48mm	Single	Serviceability	2.58	2.19	1.80	1.40	1.01	0.90	0.80	0.69	-	-	2.60	2.20	1.79	1.39	0.98	0.88	0.78	0.67	-	-
		Strength	3.68	3.43	3.17	2.91	2.65	2.45	2.24	2.04	-	-	4.00	3.66	3.33	2.99	2.65	2.49	2.32	2.15	-	-
	End	Serviceability	3.05	2.67	2.29	1.92	1.54	1.16	0.98	0.79	0.60	0.42	3.32	2.88	2.45	2.01	1.57	1.14	1.00	0.87	0.74	0.61
		Strength	5.34	4.70	4.07	3.44	2.80	2.17	1.85	1.53	1.21	0.89	6.12	5.40	4.68	3.95	3.23	2.51	2.26	2.01	1.76	1.51
	Internal	Serviceability	2.65	2.43	2.22	2.00	1.79	1.57	1.35	1.14	0.92	0.70	3.22	2.90	2.59	2.27	1.96	1.65	1.43	1.21	0.99	0.77
		Strength	5.36	4.87	4.38	3.88	3.39	2.90	2.52	2.13	1.75	1.37	7.23	6.50	5.78	5.05	4.32	3.59	3.14	2.69	2.23	1.78

The values in all of the above tables are for use with steel supports with a minimum thickness of 0.95mm, G550.

Table 6.0

WATER CARRYING CAPACITY (m) Max roof run for drainage

Roof Slope	Peak Rainfall Intensity								
	150 mm/hr	180 mm/hr	200 mm/hr	250 mm/hr	300 mm/hr	350 mm/hr	400 mm/hr	450 mm/hr	
1°	262	218	196	157	131	112	98	87	
3°	454	378	340	272	227	194	170	151	
5°	586	488	439	351	293	251	219	195	
7.5°	719	599	539	431	359	308	269	239	
10°	832	693	624	499	416	356	312	277	
15°	1026	855	769	615	513	439	384	342	

The peak rainfall intensities shown represent a 100 year average recurrence interval (ARI) for a five minute rainfall duration. If roof penetrations exist, the total roof run will generally be greater than the distance from ridge to eaves at the location the penetration interferes with the runoff. Contact Stratco if further advice is required.

Table 7.0

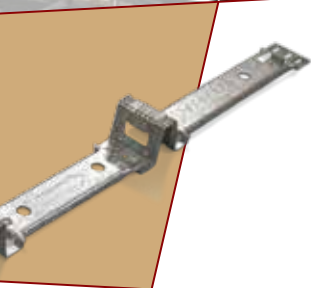

TOPDEK 700 FASTENER SELECTION – NON CYCLONIC AREAS

Support	Support Thickness	Insulation Blanket	Type of Fastener	Fastener Size
Steel	≤ 2.5mm	No	Hex head self drilling screw	No. 10 – 16 x 16mm
	≤ 2.5mm	Yes	Hex head self drilling screw	No. 10 – 16 x 25mm
	> 2.5mm ≤ 5.0mm	No	Hex head self drilling screw	No. 10 – 24 x 16mm
	> 2.5mm ≤ 5.0mm	Yes	Hex head self drilling screw	No. 10 – 24 x 25mm
	> 5.0mm	With or without	Drill 4.5mm tapping hole	No. 10 – 24 x 25mm
Timber (Hardwood)	> 100mm	With or without	Type 17 self drilling wood screws	No. 10 – 11 x 30mm
Timber (Softwood)	> 100mm	With or without	Type 17 self drilling wood screws	No. 10 – 11 x 30mm

Fastener sizes are suitable for fixing over an insulation blanket up to 55mm thick, for thicknesses up to 100mm, use the next screw length to the one indicated.

Table 8.0

INSTALLATION

Step One

Align the top and bottom clips of the first sheet along the purlins with the arrow pointing in the laying direction, and fasten in positions 1, 2 and 3 (refer to Step 1 below) using the number and type of fasteners specified in the span tables and table 8.0 above. Run a string line between the two clips, or use the edge of the first deck to ensure all clips are in line. Mark the top, bottom and middle purlins at one metre from the starting line and at 700mm centres across the purlins. Use these marks to keep the sheets square.

Align the remainder of the first run of clips to the string line and along the purlins. Fasten in position A, B and C (refer to Step 1 below) using the number and type of fasteners specified.

Step Two

Place the first sheet over the clips ensuring a minimum projection of 75mm at the ridge and into the gutter. Snap each rib onto the clip at every purlin using steady foot pressure, ensuring complete deck engagement at every rib on every clip, see the diagram below.

Hook the next run of clips over the last rib of the first sheet. The clips will align themselves and must be butted together for correct positioning. Align the hole with the slot and fasten at the joint first, then work along the bracket. During laying, regularly check the sheets for fanning or creep. If minor adjustment is necessary, the clips can be pulled away from the sheet while fastening.

Step Three

Place the second sheet over the clips, ensure the end of the sheet aligns with the first sheet. Snap the deck onto the clips in the laying order using steady foot pressure and fully engage the interlocking rib onto each clip. It is important to ensure the deck is engaged on each rib, on every clip, and the deck is engaged along its entire length.

Install the remaining clips and sheets. Remember to frequently check the coverage to maintain squareness and adjust for creep where necessary. At the end of the purlin, cut the clips and deck where necessary to suit. To secure the final sheet edge, cut the end off the bracket, hook over the last rib and fasten. Finally, remember to turn up the pans at the ridge and down at the gutter end.

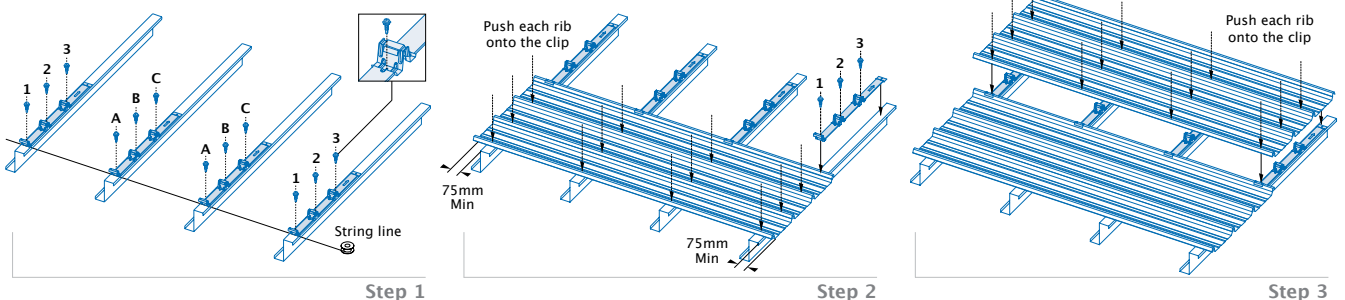

CONTACT

1300 165 165

WALKING ON TOPDEK 700

When walking on Topdek 700 roofing, it is recommended you walk over the purlins to avoid any damage. Wear flat, rubber soled shoes and walk flat footed in the sheet pans only. For carport and verandah applications, use crawl boards to avoid damage during installation and maintenance.

ORDERING

Sheets are available custom cut, allowing you to minimise waste, and enhance your design options. Topdek 700 is available in un-painted zinc/alum, and in an attractive range of factory pre-painted colours. Subject to the delivery location, quantity and material availability, delivery is usually within 48 hours, or at an agreed time that suits your building schedule. Unless advised differently, a one tonne maximum is usually applied to larger packs. Arrangements for unloading the truck are the responsibility of the customer, and should be arranged before ordering. When unloading you must ensure the load is adequately spread. Use spreaders and slings to prevent damage. If packs are to be loaded directly above structural members, they must be of sufficient strength, such as over portal frames, or braced roof trusses.

USING TOPDEK 700

Stratco Topdek 700 will have a long, useful life if used according to Stratco specifications. While roofing materials in outer urban and rural areas may have a life-span in excess of 30 years, this can reduce to only a few years in coastal and industrial environments.

Zinc/alum and pre-painted steel should not be used in very aggressive areas such as near swimming pools and spas. It is important that dirt, soil, compost, paving sand, or other materials which retain moisture are not placed against steel sheeting. Concrete should not be poured against zinc/alum material. Check with Stratco before using in these severe environments.

Incompatible Metals

The best way of reducing corrosion is to keep incompatible metals apart. Zinc/alum and pre-painted steel cannot be used with lead, copper and monel. Galvanised steel and pure zinc material can be used with zinc/alum, but you must avoid water run-off from zinc/alum onto galvanised material. Fixings such as rivets and self-drilling screws must be compatible with the material they are fixing.

Handling and Cutting of Topdek 700

For safety, wear gloves when handling Topdek 700. Ensure your hands or gloves are clean, especially when handling zinc/alum which can mark. Use a coloured pencil for marking steel, as lead or black pencils contain graphite which promotes rusting. Topdek 700 is best cut using tin snips, but for larger cuts it may be necessary to use a power saw with a steel cutting blade or a power nibbler. Avoid using abrasive discs as they can cause burred edges and coating damage. Where possible cut sheets on the ground, and always clean off any swarf and metal filings progressively during the installation. Dispose of off-cuts carefully.

Insulation and Sealants

The use of blanket insulation is recommended in domestic roofing to assist in temperature, condensation and sound control. Topdek 700 can be used with an insulating blanket up to 55mm thick. Increased thicknesses require longer fasteners and greater care when installing.

When choosing a silicone sealant, ensure it is suitable for roofing and guttering use and of a non-acetic, amine free, neutral cure type. Sealants that smell of ammonia, vinegar or lemons are not usually suitable.

MAINTENANCE REQUIREMENTS

The performance of Topdek 700 over time depends on its correct application and maintenance. Maintenance should be performed as often as is required to remove any dirt, salt and pollutants. Where used in severely corrosive environments, cleaning should be performed more often. It is important that screws have the same life expectancy as the cladding you have specified.

Packs of Topdek 700 should always be kept dry and stored above ground level while on site. If the sheets have become wet, they should be separated, wiped and placed in the open to dry.

Refer to the Stratco "Selection, Use and Maintenance" brochure, for more detailed information about the correct use and maintenance of this product.