



# Stramit Condeck HP<sup>®</sup> decking



**STRAMIT CONDECK HP<sup>®</sup>**  
COMPOSITE DECKING

**Stramit Condeck HP<sup>®</sup>** decking is a cold rolled formed section manufactured from high strength galvanised steel in thicknesses of 0.75mm, 0.90mm and 1.00mm.

**Stramit Condeck HP<sup>®</sup>** decking is a permanent structural formwork system. It can be used for all suspended slab construction for domestic commercial and industrial applications.

- Positive reinforcement for concrete slabs
- Reduced temporary propping
- Easier and faster construction
- A unique rib geometry that allows for suspended ceiling systems or services



installation procedure

## Ordering

- Cut to length should allow  $\pm 5\text{mm}$  for manufacturing tolerances
- Length ordered should be **site measurements** and not plan dimensions
- Remember to add at least 100mm to required length to allow for **50mm bearing** each end
- To determine number of sheets, divide the width of area to be covered by 300mm

## Installation

### I. Material to site

- **Stramit Condeck HP<sup>®</sup>** decking must remain dry
- Support clear of ground with a fall for drainage
- If sheets become wet, dry by hand, store under cover and away from condensation
- If packed in long bundles, sling with adequate supports onto supporting framework

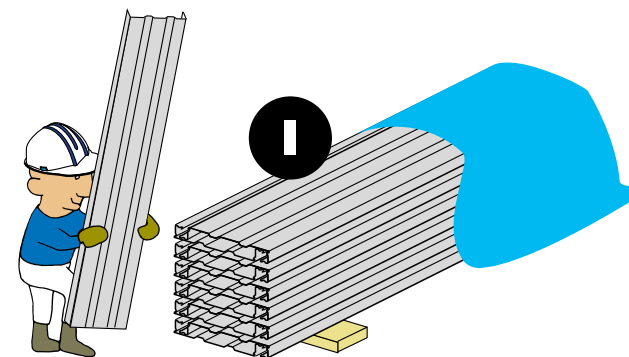

### 2. Loose laying

- **Dampcourse** is to be laid over all **brick or masonry support surfaces**
- Loose lay from a safe working side
- Hinge into position at each side lap
- Ensure a minimum end bearing of 50mm
- When end joining **Stramit Condeck HP<sup>®</sup>** decking sheets, ensure join is over a structural support

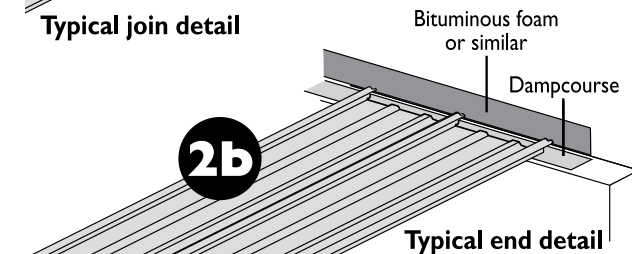
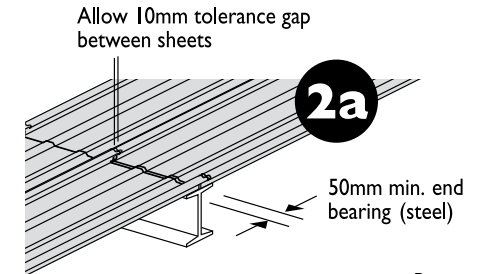
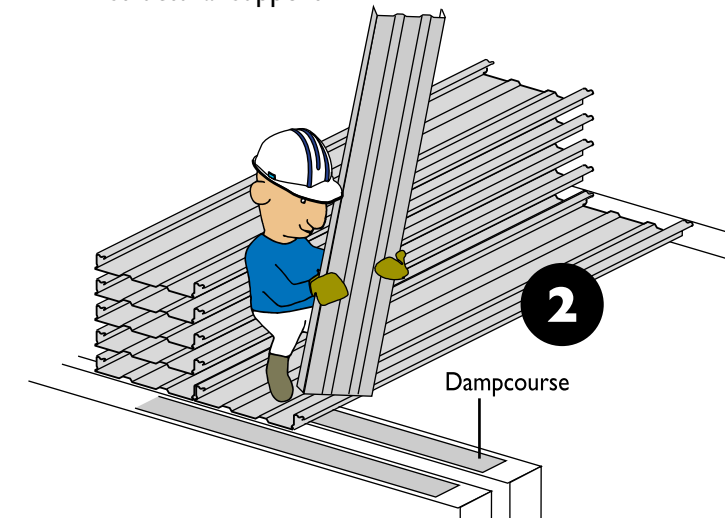

### 3. Temporary propping

- Prop at specified centres
- In the shaded area of the **Stramit Condeck HP®** decking propping tables, where the deck is to be left exposed underneath, place **450mm wide compressible fibre sheets or plywood** between timber bearer and deck to reduce effect of propping 'lines'
- **Do not prop too high** – props should not protrude above the supporting structure
- Bed props adequately to take wet concrete loading
- More stable propping frames are easier to use than individual props

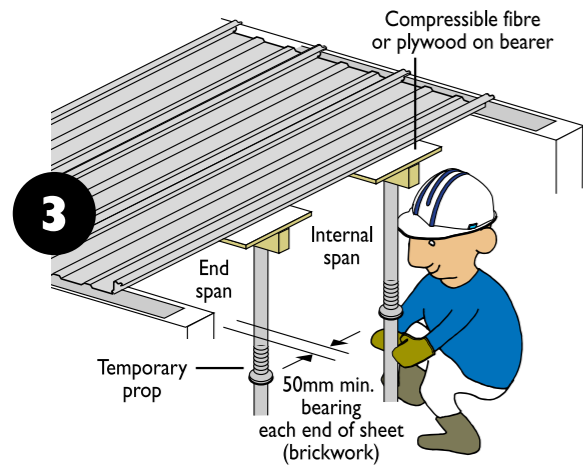

#### End support fixing

Fastener location

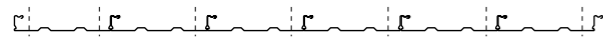

#### Internal support fixing

Fastener location (first & last sheet plus every 3rd rib)

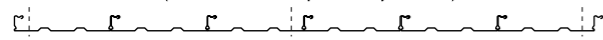

Now you're ready to fix **Stramit Condeck HP®** decking and pour the concrete

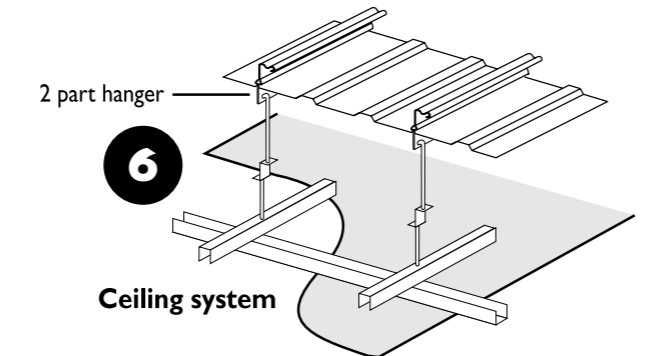
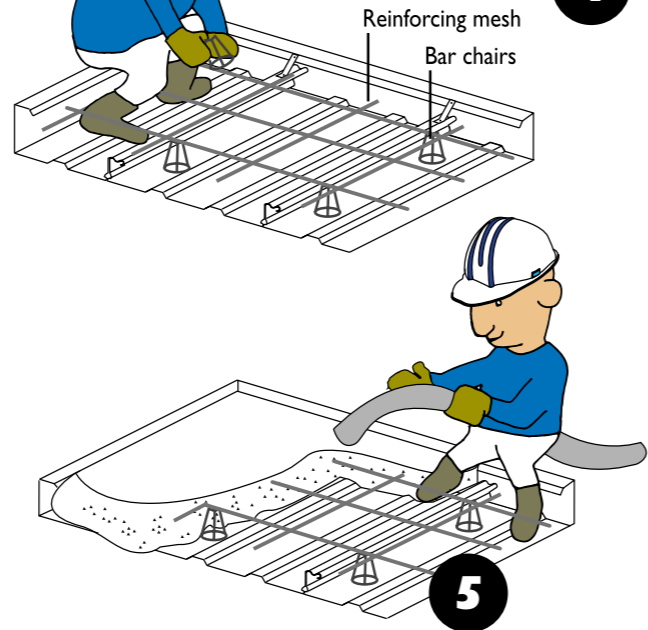
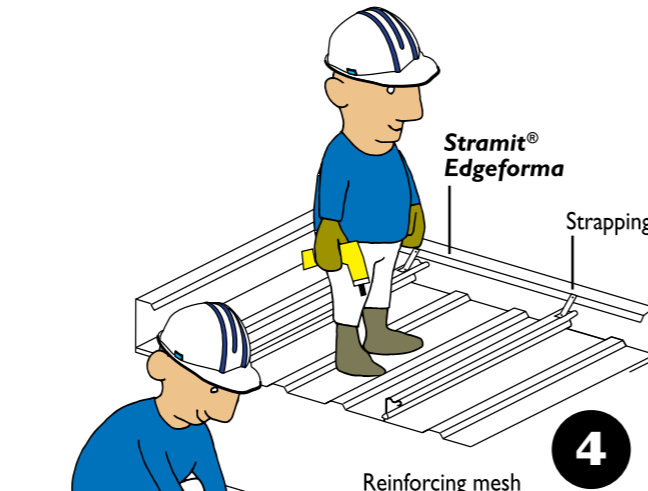

### 4. Fixing

- End fix sheets where required
- Cut, notch and attach **Stramit Edgeforma**
- Cut, position and place reinforcing mesh on bar chairs to ensure specified (minimum 25mm) concrete cover

### 5. Concrete

- Decking panels should be cleaned prior to placing concrete
- Pump, bucket or barrow concrete into position
- **Do not allow concrete to heap**
- Consolidate with vibrator and ensure concrete is packed up and around top rib
- Screed by hand or with helicopter
- **Temporary props must be left in place** until the concrete has reached 75% of its 28 day characteristic strength

**For information regarding stairways, cantilever balconies, openings etc., refer to your local Stramit office.**

### 6. Suspended Ceilings

**Stramit Condeck HP®** decking has provision for suspended ceiling installation or support for services.

Simply insert the 2 part hanger bracket after the concrete has set.

Call us for further information  
or the name of your local distributor



<p><b>SYDNEY</b> 33-83 Quarry Road, Erskine Park NSW 2759 Telephone (02) 9834 0900 Facsimile (02) 9834 0988</p> <p><b>CANBERRA</b> 4 Bass Street, Queanbeyan NSW 2620 Telephone (02) 6297 3533 Facsimile (02) 6297 8089</p> <p><b>COFFS HARBOUR</b> 6 Mansbridge Drive, Coffs Harbour NSW 2450 Telephone (02) 6656 3800 Facsimile (02) 6656 3808</p> <p><b>NEWCASTLE</b> 17 Nelson Road, Cardiff NSW 2285 Telephone (02) 4954 5033 Facsimile (02) 4954 5856</p> <p><b>ORANGE</b> 51 Leewood Drive, Orange NSW 2800 Telephone (02) 6361 0444 Facsimile (02) 6361 9814</p> <p><b>MELBOURNE</b> 2/1464 Ferntree Gully Road, Knoxfield VIC 3180 Telephone (03) 9237 6200 Facsimile (03) 9237 6299</p> <p><b>ALBURY</b> 18 Ariel Drive, Albury NSW 2640 Telephone (02) 6041 7600 Facsimile (02) 6041 7666</p> <p><b>BENDIGO</b> Ramsay Court, Kangaroo Flat VIC 3555 Telephone (03) 5448 6400 Facsimile (03) 5447 9677</p> <p><b>MILDURA</b> 19-23 Adams Street, Mildura VIC 3500 Telephone (03) 5018 4800 Facsimile (03) 5021 0557</p> <p><b>HOBART</b> 57 Crooked Billett Drive, Brighton TAS 7030 Telephone (03) 6263 5536 Facsimile (03) 6263 6950</p>	<p><b>ADELAIDE</b> 11 Stock Road, Cavan SA 5094 Telephone (08) 8262 4444 Facsimile (08) 8262 6333</p> <p><b>BRISBANE</b> 57-71 Platinum Street, Crestmead QLD 4132 Telephone (07) 3803 9999 Facsimile (07) 3803 1499</p> <p><b>TOWNSVILLE</b> 402-408 Bayswater Road, Garbutt QLD 4814 Telephone (07) 4412 3900 Facsimile (07) 4412 3909</p> <p><b>CAIRNS</b> Vickers Street, Edmonton QLD 4869 Telephone (07) 4034 6555 Facsimile (07) 4034 6511</p> <p><b>MACKAY</b> Brickworks Court, Glenella QLD 4740 Telephone (07) 4965 4000 Facsimile (07) 4965 4012</p> <p><b>MARYBOROUGH</b> 10 Activity Street, Maryborough QLD 4650 Telephone (07) 4123 9500 Facsimile (07) 4123 9508</p> <p><b>ROCKHAMPTON</b> 41 Johnson Street, Parkhurst QLD 4702 Telephone (07) 4921 5600 Facsimile (07) 4921 5608</p> <p><b>DARWIN</b> 55 Albatross Street, Winnellie NT 0820 Telephone (08) 8930 6333 Facsimile (08) 8930 6308</p> <p><b>PERTH</b> 605-615 Bickley Road, Maddington WA 6109 Telephone (08) 9493 8800 Facsimile (08) 9493 8899</p>
---	--

© Registered trademarks of Stramit Corporation Pty Limited.

ABN 57 005 010 195 trading as Stramit Building Products

A member of the Fletcher Building Group © Stramit Corporation Pty Limited, August 2015.  
This document replaces all previous issues. Please destroy, or clearly mark as superseded, all previous issues.