

# Steeline Quad Gutter

125-150 HIGH FRONT

ST07



**125**



**150**

**Colorbond® Zinalume®**

Steeline quad gutter is the traditional gutter that still gives your home that modern look. Steeline quad is manufactured with overflow slots so your home can be protected from water overflow. By using concealed brackets, Steeline quad gutter is given a smooth unobstructed appearance. Made from Colorbond or Zinalume steel, Steeline quad gutter is strong and long lasting.

**Ph. 1300 STEELINE**

**[steeline.com.au](http://steeline.com.au)**



**Service over and above**

# Steeline Quad Gutter

125-150 HIGH FRONT

ST07

## Installation

### Fixing to timber fascia

Fix a bracket at the high end of fall first, then fix a bracket at the low end of the fall. Stringline a common datum on both brackets, and install the remaining brackets at the required spacings (not exceeding 1200mm), with common datum on the stringline.

The brackets are best attached to the fascia with the use of 20mm bugle head self drilling screws.

### Attaching gutter to brackets

Hook the front of the gutter onto the end of the long arm of the brackets, and slide the back of gutter under the long arm until it is hard up to the back of the bracket. Push the gutter into the upright position, lifting the bottom of the gutter onto the platform provided by the bracket. When the gutter is in the correct position, turn down both tabs of the gutter brackets onto the back of the gutter, completing the attachment.

### Spring Clip System

Fixing to metal fascia is made incredibly simple by using the Steeline spring clip. The clip snaps over the metal fascia, and has six teeth at alternative heights. The fall of gutter to downpipe outlet is determined by the height of where the gutter is attached to these teeth. The face of gutter is then supported by the Steeline overstraps, which connect to the front bead of gutter and top bead of fascia.

## Support Recommendations

Gutter brackets are to be placed at stop ends, and between stop ends at intervals of no more than 1200mm. where metal fascia is used, brackets must be placed within 150mm either side of the rafter brackets.

### Stop Ends

Pre-formed stop ends provide a neat finish to straight runs of gutter, and require less labour and skill than site formed ends. However both methods of end stopping require the use of rivets and a roofing type silicone sealant.

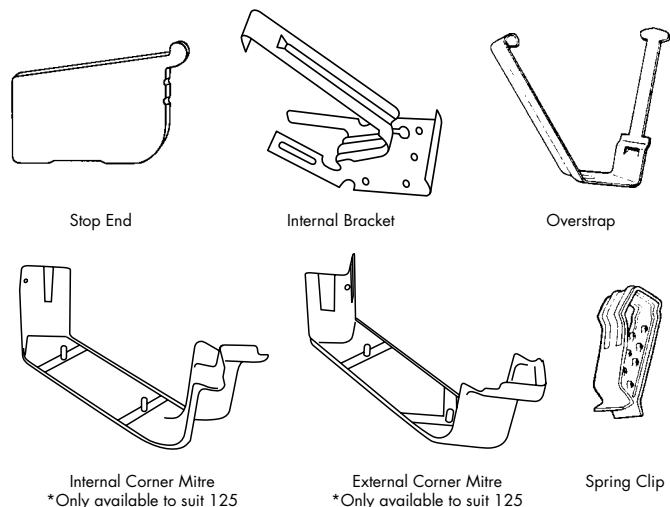

## External Corners 125 Only\*

Cut the gutter ends at 45 as shown. Fix external and internal corner over mitred cuts, use rivets or screws and silicone.

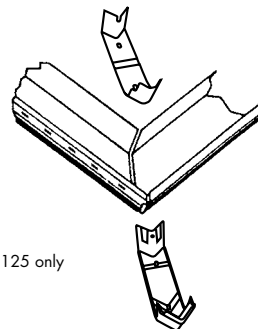

For 125 only

## Internal Corners 125 Only\*

Cut gutter ends at 45 as shown. Assemble in a similar manner to external corners.

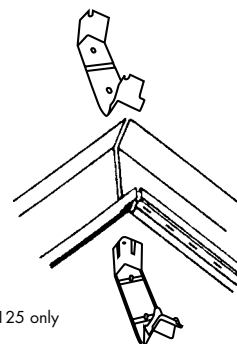

For 125 only

## Gutter Joining

Reduce the top rib for 25mm to allow for a slip joint. Slide the reduced end into the other end, applying a suitable sealant, then blind rivet together.

