

Steeline Quad Gutter

115-125-150 HIGH FRONT

ST11



115



125



150

Colorbond® Zinalume®

Steeline Quad is a traditional gutter that still gives your home that modern look. A choice can be made from 3 sizes available to compliment the project at hand. Each gutter has a smooth and unobstructed appearance and with the option of the larger sizes to facilitate the catchment of more water from the roof area during a heavy storm. Made from Zinalume & Colorbond Steel. Steeline Quad is strong and long lasting.

Ph. 1300 STEELINE

steeline.com.au



Service over and above

Steeline Quad Gutter

115-125-150 HIGH FRONT

ST11

Installation

Fixing to timber fascia

Fix a bracket at the high end of fall first, then fix a bracket at the low end of the fall. Stringline a common datum on both brackets, and install the remaining brackets at the required spacings (not exceeding 1000mm), with common datum on the stringline.

The brackets are best attached to the fascia with the use of 12 x 25 wafer head self drilling screws.

Attaching gutter to internal brackets

Hook the front of the gutter onto the end of the long arm of the brackets, and slide the back of gutter under the long arm until it is hard up to the back of the bracket. Push the gutter into the upright position, lifting the bottom of the gutter onto the platform provided by the bracket. When the gutter is in the correct position, turn down both tabs of the gutter brackets onto the back of the gutter, completing the attachment.

Attaching gutter with external brackets

Lift the gutter into the external bracket. Position correctly for corners or stop ends. Fold front and back tabs down into gutter to hold firmly in position.

Spring Clip System

Fixing to metal fascia is made incredibly simple by using the Steeline spring clip. The clip snaps over the metal fascia, and has six teeth at alternative heights. The fall of gutter to downpipe outlet is determined by the height of where the gutter is attached to these teeth. The face of gutter is then supported by the Steeline overstraps, which connect to the front bead of gutter and top bead of fascia.

Support Recommendations

Gutter brackets are to be placed at stop ends, and between stop ends at intervals of no more than 1000mm. Where metal fascia is used, brackets must be placed within 150mm either side of the rafter brackets.

Stop Ends

Pre-formed stop ends provide a neat finish to straight runs of gutter, and require less labour and skill than site formed ends. However both methods of end stopping require the use of rivets and a roofing type silicone sealant.

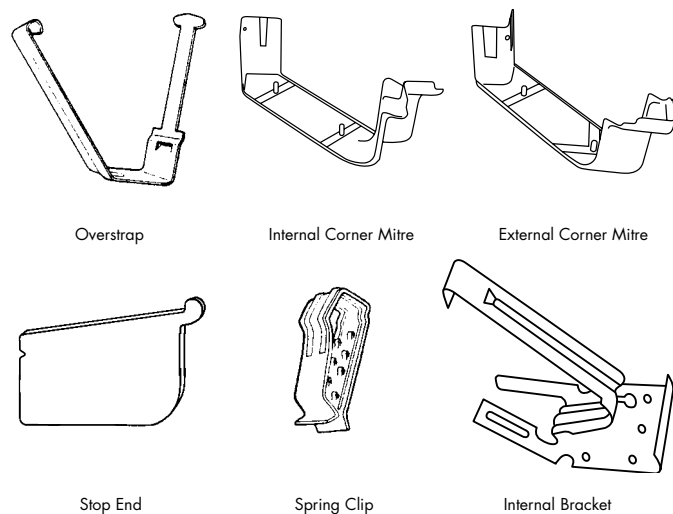

External Corners

When cutting the gutter lengths, allow an extra 165mm past the outside fascia. Cut the gutter ends at 45 as shown. Fix external and internal corner over mitred cuts, use rivets or screws and silicone.

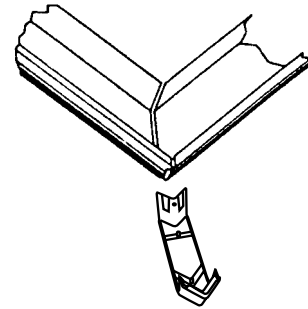

Internal Corners

Cut gutter ends at 45 as shown. Assemble in a similar manner to external corners.

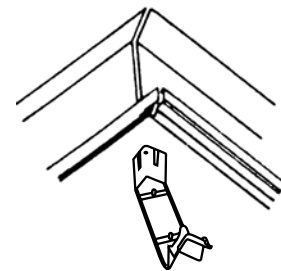

Gutter Joining

Reduce the top rib for 25mm to allow for a slip joint. Slide the reduced end into the other end, applying a suitable sealant, then blind rivet together.

