

# Steeline Heritage Gutter

HERITAGE GUTTER

ST14



## Colorbond® Zinalume®

Steeline Heritage Gutter is the ideal gutter to give your home that modern look. The gutter profile is especially popular for newer style buildings, it has its own distinctive look from the standard gutters available today and has excellent water carrying capacity. Heritage Gutter is made from COLORBOND® or ZINCALUME® Steel that is strong and long lasting.

Ph. 1300 STEELINE

[steeline.com.au](http://steeline.com.au)



Service over and above

# Steeline Heritage Gutter

HERITAGE GUTTER

ST14

## Installation

### Fixing to timber fascia

Fix a bracket at the high end of fall first, then fix a bracket at the low end of the fall. Stringline a common datum on both brackets, and install the remaining brackets at the required spacings (not exceeding 1200mm), with common datum on the stringline. The brackets are best attached to the fascia with the use of 20mm bugle head self drilling screws.

### Attaching gutter to brackets

Hook the front of the gutter onto the end of the long arm of the brackets, and slide the back of gutter under the long arm until it is hard up to the back of the bracket. Push the gutter into the upright position, lifting the bottom of the gutter onto the platform provided by the bracket. When the gutter is in the correct position, turn down both tabs of the gutter brackets onto the back of the gutter, completing the attachment.

### Spring Clip System

Fixing to metal fascia is made incredibly simple by using the Steeline spring clip. The clip snaps over the metal fascia, and has six teeth at alternative heights. The fall of gutter to downpipe outlet is determined by the height of where the gutter is attached to these teeth. The face of gutter is then supported by the Steeline overstraps, which connect to the front bead of gutter and top bead of fascia.

## Support Recommendations

Gutter brackets are to be placed at stop ends, and between stop ends at intervals of no more than 1200mm. where metal fascia is used, brackets must be placed within 150mm either side of the rafter brackets.

### Stop Ends

Pre-formed stop ends provide a neat finish to straight runs of gutter, and require less labour and skill than site formed ends. However both methods of end stopping require the use of rivets and a roofing type silicone sealant.

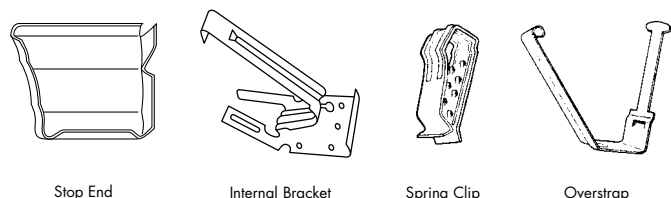

Stop End

Internal Bracket

Spring Clip

Overstrap

## Gutter Joining

Reduce the top rib for 25mm to allow for a slip joint. Slide the reduced end into the other end, applying a suitable sealant, then blind rivet together.

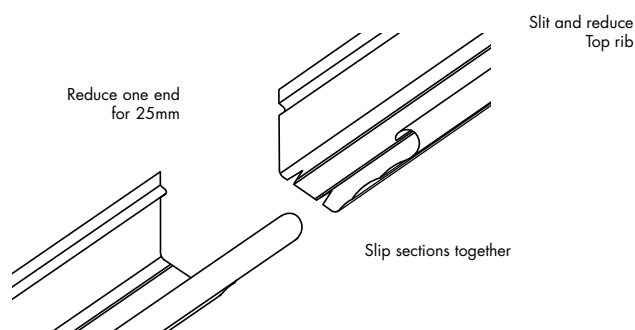

## External Corners

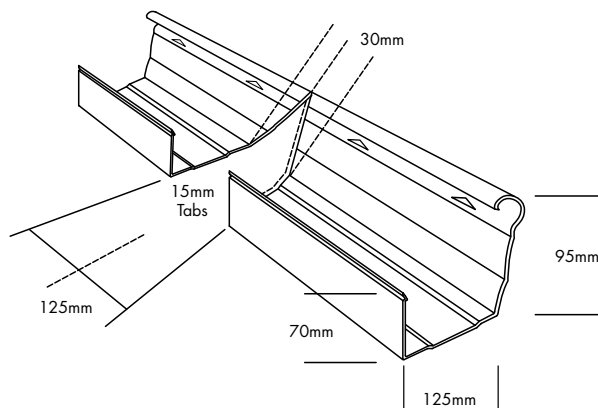

## Internal Corners

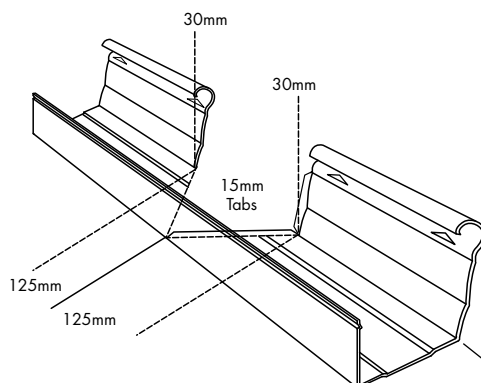

Heritage Gutter internal and external corners can be cut and folded around a corner in the same fashion as square gutter or fabricated in 2 pieces as for external corners. (if making from 2 pieces, allow a 15mm tab for joining). The following is the method for 2 pieces.

- The back and bottom of the gutter is marked as for normal mitre
- From the bottom of the gutter, to the outside point of the bead, mark 30mm longer than the perpendicular and join this mark to the mark at the bottom of the gutter
- Mark both sides of the corner opposite
- On one of the components, mark an extra 15mm tab on the 3 sides (front, base and back) for joining
- Cut the notch accordingly
- Fold front and back tabs to 90 degrees
- Rivet and seal (ensure tabs are to inside)