

# SHARPLINE<sup>®</sup> ROOF AND WALL CLADDING

Product Technical Manual

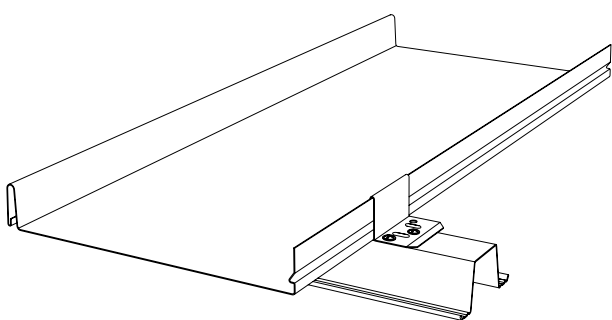

# SELECTION AND SPECIFICATION



SHARPLINE® CLIP FIX CLADDING

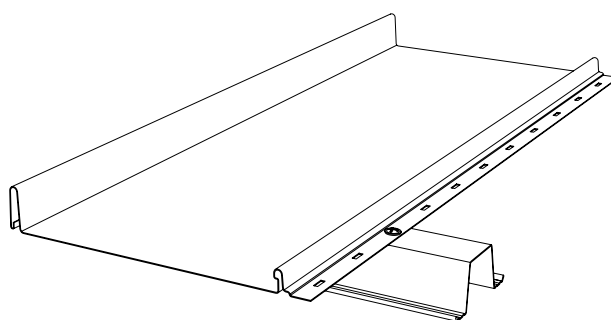

SHARPLINE® DIRECT FIX CLADDING

## FEATURES (COMMON ACROSS BOTH PROFILES)

- Visually striking with tall, sharp ribs and narrow pans
- Available in 25mm and 38mm rib heights
- 8 different tray widths are available to provide a range of design options
- Available in standard and matt COLORBOND® colours, as well as ZINCALUME® steel and Unicote® Lux
- Manufactured from non-combustible materials
- 3° minimum pitch to suit most traditional roofing applications
- Fully tested and NCC compliant with a full range of load performance data tables to suit most applications.

## APPLICATIONS

Part of Stramit's premier Architectural range, SharpLine® cladding can be installed horizontally, vertically or diagonally to suit the architectural requirements of the project.

Two fixing systems to enhance buildability, and a variety of finishes make SharpLine® cladding an easy choice for architectural cladding.

The SharpLine® clip must be installed with care using flat headed screws. If the screw is not installed straight causing the head to protrude, or if the next sheet is pressed down too hard, visible marking may result at the screw locations.

## IMPORTANT NOTICE AND DISCLAIMER

The information contained within this brochure is for general use and information only. Before application in a particular situation, Stramit recommends that you obtain appropriate independent qualified expert advice confirming the suitability of product(s) and information in question for the application proposed. While Stramit accepts its legal obligations, be aware however that to the extent permitted by law, Stramit disclaims all liability (including liability for negligence) for all loss and damage resulting from the use of the information provided in this brochure.

## MATERIALS

Stramit's SharpLine® cladding is manufactured from G300 colour coated steel, aluminium-zinc-magnesium or zinc-aluminium alloy coated steel. In some locations severe environment colour-coated steel may be available by arrangement.

Colour-coated steels are in accordance with AS/NZS2728 - Category 3 and, for the substrate, with AS1397. Aluminium-zinc-magnesium alloy coated AM100/AM125, zinc-aluminium alloy coated AZ150 conforms to AS1397.

Stramit has a comprehensive range of colours as standard. Ask your nearest Stramit location for colour availability.

SHARPLINE® CLADDING COLORBOND® XRW 0.55mm BMT - SHEETING MASS (kg/m <sup>2</sup> OF ROOF AREA)			
FIXING	RIB HEIGHT	COVER	MASS
Clip	25	320	5.56
	25	520	5.13
	38	285	6.25
	38	485	5.50
Direct	25	290	6.14
	25	490	5.45
	38	265	6.72
	38	465	5.74

## ADVERSE CONDITIONS

SharpLine® roof and wall cladding will give excellent durability in almost all locations. It is however important to choose the correct coating for each application environment as shown in the table below. Durability recommendations do vary based on the application of the product, in roofing or walling installations. Please read the tables below carefully.

Suitability of coating type	Roof sheeting - site exposure condition			Wall cladding - distance from marine environment
	mild/moderate	severe marine	very severe marine	
COLORBOND®	✓	✗	✗	>1km
COLORBOND® ULTRA	N/A	✓	✗	>500m
MagnaFlow®	N/A	✓	✗	>500m

The approximate site exposure conditions in the table above are defined below.

Site exposure condition	Roof sheeting - distance of site from	
	breaking surf / exposed marine	calm marine
mild / moderate	>200m	>100m
severe marine	>100m	>0m
very severe marine	>0m	>0m

The suitability and exposure tables above are current at the time of publication and are guidelines only; conditions will vary from site to site. Please check the Bluescope Technical Bulletins at [www.bluescopesteel.com.au](http://www.bluescopesteel.com.au) for the latest information and guidance on selection, maintenance and durability. If uncertain about the appropriate coating for a particular application, or if the product is to be used in environments affected by industrial emissions, fossil fuel combustion, animal farming, or has unwashed areas, please contact your nearest Stramit office for advice.

## COMPATIBILITY

All building products need to be checked for compatibility with adjacent materials. These checks need to be for both direct contact between materials, and where water runs from one material to another. The following guidelines generally avoid material incompatibility:

- For zinc-aluminium alloy coated steel, colour coated steel and galvanised steel roofs **avoid** copper, lead, green or treated timber, stainless steel, uncoated steel and mortar or concrete.

## TESTING

Stramit has in-house, purpose built, air-box testing equipment used to design, develop and improve products for the Australian market. In addition, many Stramit® products are tested by independent organisations.

This ongoing research and development activity ensure that Stramit remains at the forefront of innovation, design and consumer information.

## ARCHITECTURAL SPECIFICATION

This specification can be found on the Stramit web site and can be easily downloaded onto your documentation.

The roofing/walling shall be 0.55mm BMT Stramit SharpLine® cladding in continuous lengths with 25 or 38mm high ribs and flat trays spaced at specified centres to suit clip or direct fixing methods.

Sheeting material shall be protected steel sheet to Australian Standard AS1397, with a minimum yield stress of 300MPa (Grade G300) and an AM100/AZ150 coating with an oven-baked paint film of selected colour, or a plain AM125/AZ150 coating.

The sheeting shall be fixed to the purlins/girts in accordance with the manufacturer's recommendations. Suitable fixing screws in accordance with Australian Standard AS3566, Class 3, shall be used at every support.

Sheets shall be laid in such a manner that the approved side lap faces away from the prevailing weather.

A minimum of 50mm shall be provided for projection into gutters. Flashings shall be supplied in compatible materials as specified; minimum cover of flashing shall be 150mm.

All sheeting shall be fixed in a workman-like manner, leaving the job clean and weathertight.

All debris (nuts, screws, cuttings, filings etc.) shall be cleaned off daily.

# DESIGN

## SPAN TABLES

Stramit tests to Australian Standard AS1562.1 called up in the National Construction Code to provide span load tables.

The spans shown below are based on the direct pressure testing method described in the current version of AS1562.1 and take account of foot traffic and wind resistance including local pressure zone effects.

Pressures are based on AS4055 or AS1170.2. Where the two standards differ, the worst case has been taken for each classification.

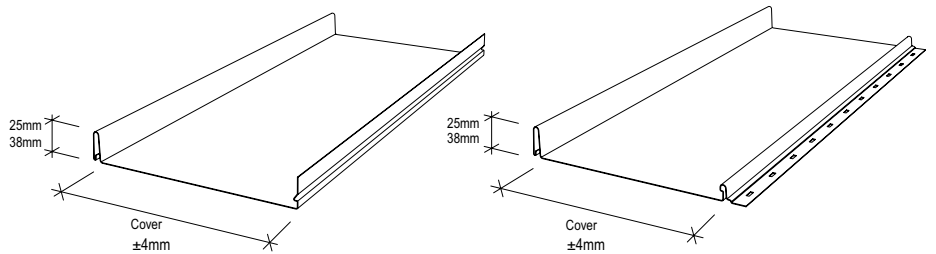

Data should only be used for buildings 7m or less in height, 1000m<sup>2</sup> or less in area, where both length and width exceed the building height and site is unaffected by land topography.

Designs for the most popular profiles are shown below.

SHARPLINE® CLADDING MAXIMUM SPAN CHART (mm) USING DIRECT PRESSURE (AIR BOX) TEST METHOD.												
Style	Rib Height (mm)	Cover (mm)	Pressure (kPa) Strength	ROOF			Pressure (kPa) Strength	WALL			OVERHANGS	
				Double spans	Equal spans	Internal (end) spans		Double spans	Equal spans	Internal (end) spans	free edge	stiffened edge
<b>N1 or Region A (TC3, FS) Wind Classification</b>												
Direct fix	25	290	1.81	600	600	900(600)	0.94	1200	1200	1200(950)	50	150
		490		450+	450+	450(350)+		600	600	600(450)	50	50
	38	265		600	600	900(600)		1200	1200	1200(950)	50	150
Clip fix		465		450+	450+	450(350)+		600	600	600(450)	50	50
	25	320	1.81	600++	600++	900(600)++	0.94	1200	1200	1200(950)	50	150
	38	285		600	600	900(600)		1200	1200	1200(950)	50	150
		485		450+	450+	450(350)+		600	600	600(450)	50	50
<b>N2 or Region B(TC3,FS) or Region A (TC2.5,PS) Wind Classification</b>												
Direct fix	25	290	1.75	600	600	900(600)	1.31	1150	1200	1200(950)	50	150
		490	2.53	450+	450+	450(350)+		600	600	600(450)	50	50
	38	265	2.53	600	600	900(600)		1200	1200	1200(950)	50	150
Clip fix		465	1.75	450+	450+	450(350)+		600	600	600(450)	50	50
	25	320	1.75	600++	600++	900(600)++	1.31	1200	1200	1200(950)	50	150
	38	285	2.53	600	600	900(600)		1200	1200	1200(950)	50	150
		485	1.75	450+	450+	450(350)+		600	600	600(450)	50	50
<b>N3 or Region B(TC2.5, PS) or Region A (TC2, NS) Wind Classification</b>												
Direct fix	25	290	2.70	600	600	800(600)	2.03	800	850	950(750)	50	150
		490	3.92	450+	450+	450(350)+		550	600	600(450)	50	50
	38	265	2.70	600	600	850(600)		900	1000	1150(900)	50	150
Clip fix		465	2.70	N/A	450+	450(350)+		550	600	600(450)	50	50
	25	320	2.70	600++	600++	800(600)++	2.03	900	950	1100(850)	50	150
	38	285	2.70	600	600	900(600)		1200	1200	1200(950)	50	150
		485	3.92	N/A	N/A	N/A		N/A	450	500(400)	50	50

\* Where roof pitch is less than 10 degrees, use spans given in red italics for roof corners. Internal spans must have both end spans 20% shorter.

+ SharpLine® cladding to be fixed to minimum 15mm thick CD Grade plywood base at spans given in the table above. Maximum span of plywood 600mm

++ Where roof pitch is > 10° use plywood base as above.

**Deflection under wind uplift not accounted for. If checking for this limit, please refer to serviceability pressures given in the wind pressure tables.**

Values are only valid for use on steel supports 0.55mm G550 or thicker. Where thinner supports are used, fastener capacity must be checked. For 0.48mm thick battens, use #10x25 wafer head Type 17 screws (Direct fix) or #10x16 smooth/flat head self drilling screws (Clip fix) for fixing and reduce strength capacity above by 15%. All spans and pressures based on edge and corner areas of roof, and edge area of wall. In some instances, better spans may be possible away from edges in roof. TC: Terrain category. FS, PS, NS: Full, partial and no shielding. Internal pressure coefficient +0.2/-0.3.

For more specific applications, SharpLine® cladding must be designed to the pressure and foot traffic limitations below.

## SHARPLINE® CLADDING WIND PRESSURE TABLE - NON-CYCLONIC AREAS

Stramit tests to Australian Standard AS1562.1 called up in the National Construction Code to provide wind pressure tables.

The table below shows wind pressure capacity based on the direct pressure (airbox) test method.

Tables are based on testing to AS1562.1 and AS4040 parts 0 and 2. Internal spans must have both end spans 20% shorter.

SHARPLINE® CLADDING WIND PRESSURE TABLE - NON-CYCLONIC											
Style	Rib Height (mm)	Cover (mm)	Span type	Serviceability pressure (kPa) at the span (mm) shown				Strength pressure (kPa) at the span (mm) shown			
				450	600	900	1200	450	600	900	1200
Direct fix	25	290	Internal	0.61	0.61	0.61	0.61	4.79	3.97	2.30	1.60
			Equal	0.61	0.61	0.61	0.61	4.23	3.51	2.03	1.42
			Double	0.61	0.61	0.61	0.61	3.87	3.21	1.85	1.30
Direct fix	25	490 †	Internal	0.67	0.28			3.40	2.36		
			Equal	0.67	0.28			3.01	2.08		
			Double	0.67	0.28			2.75	1.91		
Direct fix	38	265	Internal	0.80	0.80	0.80	0.80	3.93	3.66	2.65	2.01
			Equal	0.80	0.80	0.80	0.80	3.47	3.24	2.34	1.78
			Double	0.80	0.80	0.80	0.80	3.17	2.96	2.14	1.56
Direct fix	38	465 †	Internal	0.30	0.30			3.10	2.45		
			Equal	0.30	0.30			2.74	2.16		
			Double	0.30	0.30			2.50	1.98		
Clip fix	25	320+	Internal	0.66	1.05	0.79	0.53	4.16	3.53	2.52	1.88
			Equal	0.66	1.05	0.79	0.53	3.68	3.12	2.23	1.66
			Double	0.66	1.05	0.79	0.53	3.36	2.85	2.04	1.52
Clip fix	25	520 †	Internal	0.64	0.37			2.64	2.09		
			Equal	0.64	0.37			2.33	1.85		
			Double	0.64	0.37			2.13	1.69		
Clip fix	38	285	Internal	1.21	1.65	1.52	1.39	4.56	4.19	3.49	2.82
			Equal	1.21	1.65	1.52	1.39	4.03	3.71	3.08	2.49
			Double	1.21	1.65	1.52	1.39	3.69	3.39	2.82	2.28
Clip fix	38	485 †	Internal	0.38	0.64			2.37	1.88		
			Equal	0.38	0.64			2.09	1.66		
			Double	0.38	0.64			1.91	1.52		

Note: Values are only valid for use on steel supports 0.55mm G550 or thicker. Where thinner supports are used, fastener capacity must be checked. For 0.48mm thick battens, use #10x25 wafer head Type 17 screws (Direct fix) or #10x16 smooth/flat head self drilling screws (Clip fix) for fixing and reduce strength capacity above by 15%. Internal spans must have both end spans 20% shorter. † Where used on roofs, SharpLine® cladding direct fix 490, 465 and clip fixed 520, 485 to be fixed to minimum 15mm thick CD Grade plywood base at maximum 450mm spans. + For roof pitch >10° use a minimum 15mm thick CD Grade plywood base.

## FOOT TRAFFIC

SharpLine® cladding roofs may be subjected to foot traffic and the spans below conform to AS1562.1 with 1.1kN load as specified in AS/NZS1170.1 for R2 – Other Roofs.

- Controlled – spans that conform to AS1562.1 but require minimal careful foot traffic only on the designated foot path. Suggested for use only where occasional aesthetic imperfections from foot traffic are acceptable.

SHARPLINE® CONTROLLED FOOT TRAFFIC LIMITS					
style	rib height (mm)	cover (mm)	foot traffic limits (mm)		
			double	equal	internal
Direct fix	25	290	600	600	900
	25	490	450+	450+	450+
	38	265	600	600	900
	38	465	450+	450+	450+
Clip fix	25	320	600++	600++	900++
	25	520	450+	450+	450+
	38	285	600	600	900
	38	485	450+	450+	450+

+ on plywood base. See note under wind pressure tables for details. Tables are based on tests to AS1562.1 and AS4040 parts 0 and 1. ++ Plywood base where roof pitch exceeds 10°.

## SPRING CURVING

Stramit's SharpLine® cladding is not suitable for spring curving applications. It is most important that the structure behind the SharpLine® cladding is the one flat plane, so any installation distortions are reduced.

## SHEET LENGTH FOR DESIGN PURPOSES

SharpLine® cladding standard production maximum length is 9 metres. Longer lengths may be available however are not standard and should be discussed

SHARPLINE® CLADDING - MAXIMUM SHEET LENGTHS (m)		
roof colour	light	dark
Clip Fix	25	17
Direct Fix	25	17

with Stramit before designing. Due to the nature of standing seam profiles, additional care must be taken when manufacturing, handling and transporting long lengths. It's recommended that designs are made within the current standard lengths.

SHARPLINE® CLADDING MINIMUM ROOF SLOPE (DEGREES)										
Style	Rib Height (mm)	Cover (mm)	Rainfall intensity mm/hr	total roof run length (m)						max roof run length at min slope (m)
				30	40	50	60	70	80	
All	25, 38	All	200	3	3	3	3	3.0	3.2	78
			225	3	3	3	3	3.1	4.3	69
			250	3	3	3	3	4.0	5.6	62
			275	3	3	3	3.5	5.1	6.9	56
			300	3	3	3	4.3	6.2	8.5	52
			325	3	3	3.4	5.2	7.5	10	48
			350	3	3	4.0	6.2	8.9	12	44
			375	3	3	4.8	7.3	11	14	41
			400	3	3.2	5.6	8.5	12	16	39

Note: Computations based on AS1562.1

## THERMAL EXPANSION

All metal roof sheeting is subject to thermal expansion and, where there is a temperature difference between the sheeting and the structure, this needs to be accommodated. The colour of the sheeting will affect the amount of thermal expansion, and whether the sheet is flat or curved will affect its ability to resist without problems.

If longer lengths are required, sheet lengths should be limited to those shown below.

## WATER CARRYING CAPACITY

Stramit's SharpLine® cladding has excellent water-carrying capacity. Roof slopes can be as low as 3° for many applications. Roof run lengths are the combined lengths of all roof elements contributing to a single pan drainage path. This can include the roof length upstream of a roof penetration that concentrates flow into other pans.

All SharpLine® cladding profiles can be used at 3° slope for up to 30 metres run length and rainfall intensities up to 400mm/hr.

The table below gives slopes for 100-year return period rainfall intensity.

For more information on water-carrying performance, refer to Stramit's Roof Slope Guide.

## OIL CANNING

Wide, flat profiles may be subject to "oil canning", a perceived waviness in the material. This may happen in any wide, flat profiles and is usually an aesthetic issue only and the structural performance is not affected.

Since many uncontrollable factors are involved, no manufacturer can realistically assure the total elimination of oil canning.

With careful attention to the production and selection of material, to the panel design and to installation practice, oil canning can be effectively minimised.

To minimise the appearance of oil canning, use narrower profiles, lighter colours in matt finishes, ensure the sub structure is in a flat plane and fasteners are installed correctly.

## FLAMMABILITY AND COMBUSTIBILITY

Fire resistance is such an important topic and one that we take seriously at Stramit.

Stramit® roofing, cladding, rainwater and structural building products are manufactured from steel produced by BlueScope® Steel or Pacific Coil Coaters (through Selection Steel). Both

organisations have had independent tests on their materials carried out by CSIRO or AWTA. The testing was conducted in accordance with the Australian Standard AS1530.3 'Simultaneous Determination of Ignitability, Flame Propagation, Heat Release and Smoke Release.' All materials had a surface finish less than 1mm in thickness and a Spread of Flame Index of 0.

Stramit® products made from these steel sources and with the tested finishes would be considered non-combustible according to NCC 2019 Volume One Part C1.9(e) and Volume Two Part 3.7.1.1.

It is important to note that Stramit® sheeting is only one component used in construction of these building elements, and other components must also meet the necessary requirements to satisfy the criteria.

For more information, refer to the *Stramit Flammability Guide* on [stramit.com.au](http://stramit.com.au).



# PROCUREMENT

## ORDERING

SharpLine® cladding can be ordered directly, through distributors, or supplied and fixed from a roofing contractor.

## PRICES

Prices on SharpLine® cladding and its accessories can be obtained from your nearest Stramit location or distributor of Stramit® products. As Stramit does not provide an installation service, ask your tradesperson for a quote and fix price. Contact your nearest Stramit location for the names of tradespersons in your area.



SharpLine® cladding is supplied cut-to-length. When ordering or transporting long products ensure that the length is within the limit of the local Transport regulations. The manufacturing tolerance on the length of product supplied is +0, -15mm.



## RELATED PRODUCTS

**Ridge Capping -** standard or custom dimensions

**Flashings -** a range of custom flashings, barge roll etc.

Refer to the *Stramit® Roof and Wall Flashing Architectural Detailing Design Guide* available on [stramit.com.au](http://stramit.com.au)

**SharpLine® cladding clip** to suit height of product.

**Insulation & roofing mesh -** a range of mesh, Sisalation® foil insulation, plain & foil backed blanket.

## INSULATION

SharpLine® cladding is suitable for use with insulating blanket. Glasswool blanket up to 50mm thick can be readily used. Increased thicknesses require longer fasteners and greater care in installation. Ensure the length of the screw is sufficient to have a minimum of 3 threads protruding below the support. For domestic applications Stramit recommends that insulation is always used.

## DELIVERY/UNLOADING

SharpLine® cladding requires additional care when transporting and unloading.

Pack mass may be up to one tonne. When lifting SharpLine® cladding, care should be taken to ensure that the load is spread to prevent damage.

Delivery can normally be made within 72 hours, subject to the delivery location, quantity and material availability, or can be at a pre-arranged date and time.

Please ensure that suitable arrangements have been made for truck unloading, as this is the responsibility of the receiver.

## HANDLING/STORAGE

SharpLine® cladding should be handled with care at all times to preserve the product capabilities and quality of the finish. Packs should always be kept dry and stored above ground level while on site. If the sheets have become wet, they should be separated, wiped and placed in the open to promote drying.

## FASTENERS

All fasteners with Phillips head

### Direct Fix (one per sheet per support):

**Steel battens:** 0.48mm BMT - 10 x 25mm wafer head Type 17 screws

0.55mm BMT or greater - 10 x 16mm wafer head self-drilling screws

**Timber battens:** 10 x 25mm wafer head Type 17 screws

### Clip Fix (two per sheet per clip per support):

**Steel battens:** 10 x 16mm smooth/flat head self-drilling screws

**Timber battens:** 10 x 25mm smooth/flat head Type 17 screws

For plywood, use screws for timber battens. if protrusion below plywood is not desired, use 10 x 16mm flat head needle point screws.

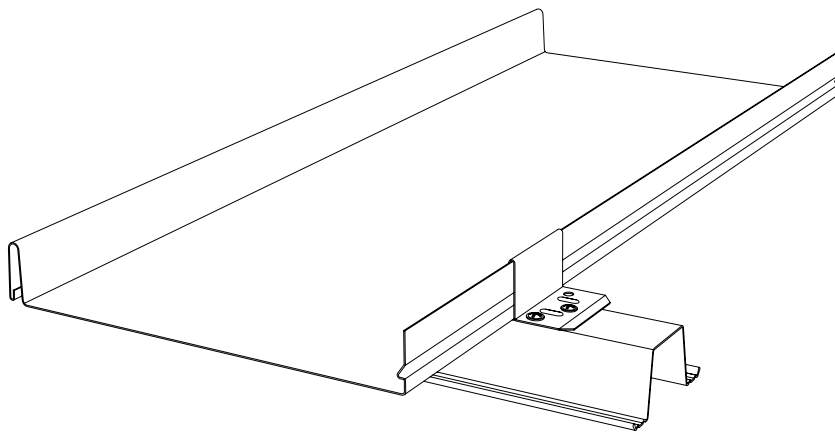

SHARPLINE® CLIP FIX CLADDING

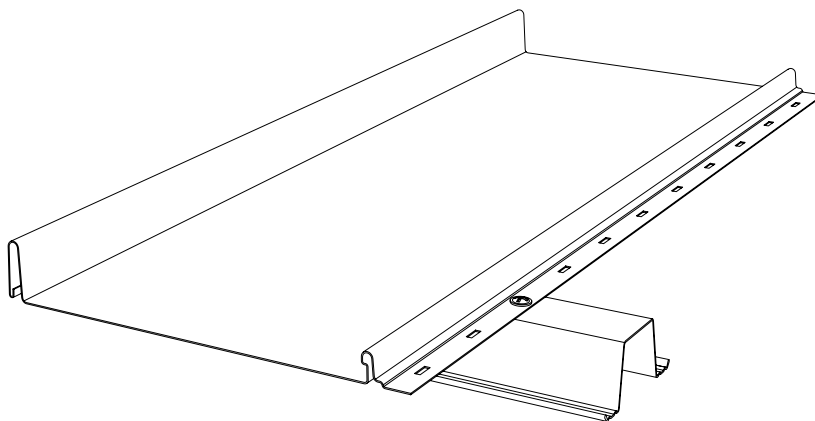

SHARPLINE® DIRECT FIX CLADDING



## SITE INDUCTION

Consideration should be given to handling and installation issues as part of site induction safety procedures. Specific consideration should be given to pack handling, avoidance of cuts, trips, slips and falls, long sheet handling particularly in windy conditions, sheet cutting procedures and surface temperature on sunny days. Personal Protection Equipment (PPE) should always be used.

## WALKING

As with all roofing products, we recommend extra caution be taken when walking on the roof. When walking on SharpLine® cladding roofing always wear flat rubber soled shoes and place feet only in the trays, taking care to avoid the last tray or two near edges of the metal roof area. Walk close to supports to avoid damage.

## GOOD PRACTICE

Stramit recommends that good trade practice be followed when using this product, such as that found in Australian Standards AS/NZ 1562.1 and handbook HB39.

## SHEET HANDLING

Cut resistant or leather gloves should be worn when handling product. Foot protection should be worn when handling and transporting product.

## CUTTING

SharpLine® cladding can be easily cold cut, where required, using a power saw with a steel cutting blade or a power nibbler and, for localised cutting, tin snips. Avoid the use of abrasive discs as these can cause burred edges and coating damage.

**Please dispose of any off-cuts carefully.**

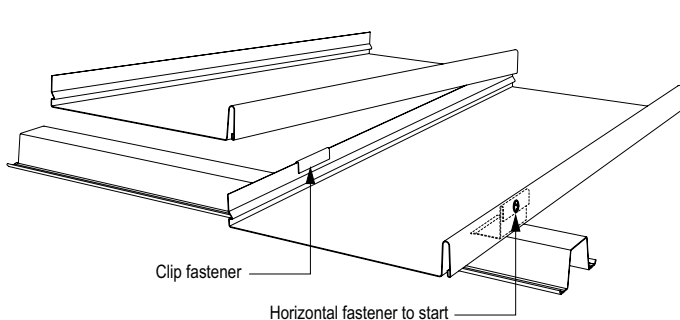

# INSTALLATION

SharpLine® cladding is readily installed with or without fiberglass insulation blanket.

The use of heavy-duty sarking is recommended to ensure weather tightness. If practical lay sheets in the opposite direction to prevailing weather.

Installation of SharpLine® cladding is a straightforward procedure using the following fixing sequence for either SharpLine® Clip or SharpLine® Direct fix.

## FASTENER LOCATION

SharpLine® clip fix cladding requires a galvanized fixing clip to be attached at the supports at every batten/purling.

SharpLine® direct fix cladding has the fasteners driven through the slots in the side edge of the sheet. If the slots do not align with the supports, drill through the roof/wall sheet with the fasteners.

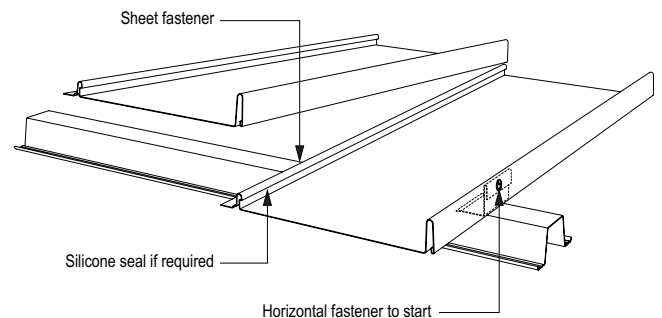

*Note that the different cover width versions of both SharpLine® clip fix cladding and SharpLine® direct fix cladding profiles can be used together to create different architectural appearances, however SharpLine® clip fix cladding and SharpLine® direct fix cladding are not compatible and cannot be used side by side.*

### SharpLine® clip fix cladding

1. Ensure all purlins/battens are in line and correctly installed and that plywood substrate, mesh, and blanket (if specified) are in place.
2. Use a string line, or the edge of the first sheet to align the first row of fixing clips. Attach the fixing clips to the structure using the correct fasteners, ensuring screws go in straight and head is not tilted or protruding.
3. Position the first sheet over the clips ensuring the correct sheet overhangs (minimum 50mm).
4. Fasten through the vertical upstand to attach

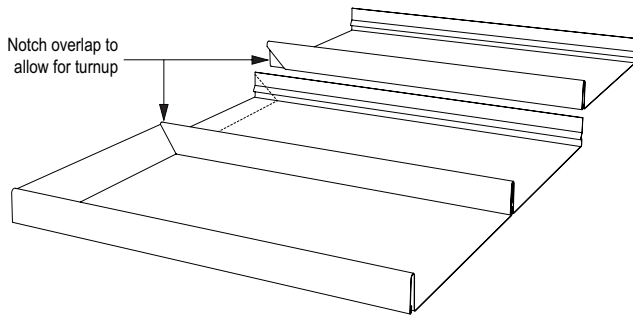

the sheet to the clip.

5. Install fixing clips to each batten using two fasteners driven in straight, placing the clip over the trailing edge of the cladding sheet.
6. Carefully lay the following sheet in place and press the interlock together along the sheet, ensuring the interlock is fully engaged. If needed, use a rubber mallet for assistance, taking care not to damage the rib.  
Note: Visible marking may result if excessive force used. If the roof pitch is less than 7.5 degrees, or the roof run length exceeds 5 meters, apply silicone sealer below the underlap rib, prior to laying the following sheet.
7. Continue to install fixing clips and subsequent sheets, checking that sheet ends at the lower edge are exactly aligned.
8. Measure the overall cover width at the top and bottom of the sheets from time to time to avoid "fanning".
9. For roofs, turn up the pans at the upper roof edge and install flashings. Turn down the bottom end of the sheet to facilitate drainage into gutters.
10. Clean up the roof after each day's work, removing all screws, cuttings, swarf etc., and leave roof clean and watertight.

### SharpLine® direct fix cladding

1. Ensure all purlins/battens are in line and correctly installed and that plywood substrate, mesh and blanket (if specified) are in place.
2. Either cut a full-length sheet of SharpLine® direct fix cladding near the trailing edge to create a starter strip or install SharpLine® cladding fixing clips to locate the first sheet (see steps 2, 3, and 4 for SharpLine® clip fix cladding installation).
3. Position and fix the first sheet over the clips ensuring the correct sheet overhangs (minimum 50mm). Ensure the screws are not overtightened.

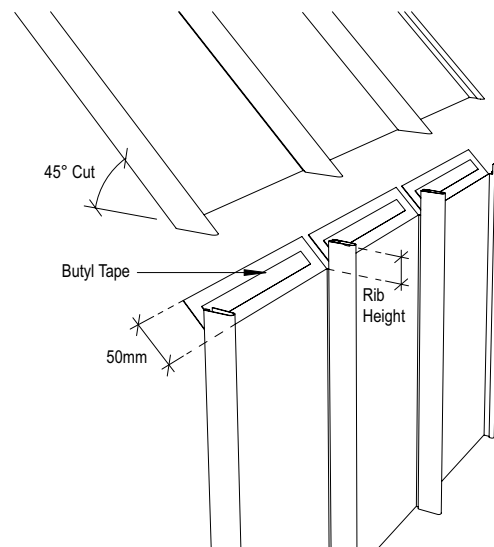

4. Carefully lay the following sheet in place and press the interlock together along the sheet, ensuring the interlock is fully engaged. If needed, use a rubber mallet for assistance, taking care not to damage the rib.  
Note: If the roof pitch is less than 7.5 degrees, or the roof run length exceeds 5 metres, apply silicone sealer below the underlap rib, prior to laying the following sheet, then fasten down with screws.
5. Continue to install subsequent sheets, checking that sheet ends at the lower edge are exactly aligned.
6. Measure the overall cover width at the top and bottom of the sheets from time to time to avoid "fanning".
7. For roofs, turn up the pans at the upper roof edge and install flashings. Turn down the bottom end of the sheet to facilitate drainage into gutters.
8. Clean up the roof after each day's work, removing all screws, cuttings, swarf etc., and leave roof clean and watertight.

## END LAPS

End lapping of SharpLine® clip fix cladding or SharpLine® direct fix cladding is not recommended. Contact Stramit Technical Services for more information.

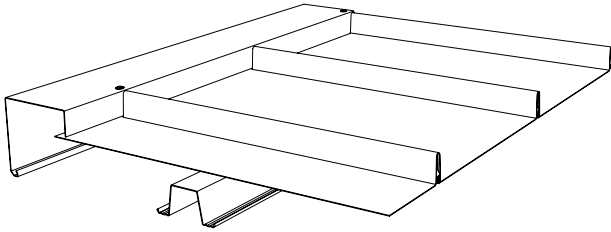

## SHARPLINE® CLADDING TURN UP DETAIL

Use a turn up/down tool to carefully and progressively fold up the top end of the sheet for approximately 25mm. Fold the sheet up as close to 90 degrees as possible. Do not tear the sheet.

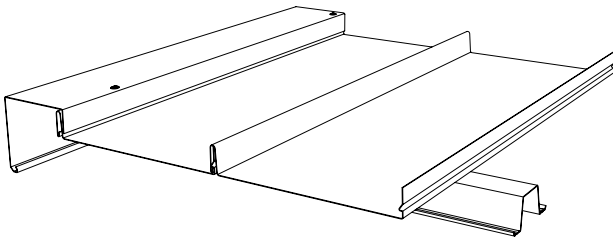

## SHARPLINE® CLADDING TURN DOWN DETAIL

Use a turn up/down tool to carefully and progressively fold down the bottom gutter end of the sheet for approximately 25mm. Do not tear the sheet.

## SHARPLINE® CLADDING ROOF TO WALL DETAIL

This common architectural detail requires the wall sheets to be cut 50mm longer than the wall height. The top end of the wall sheet is notched and a 50mm fold created to sit below the roof sheet.

The roof sheet is also notched at the bottom end to match the wall rib height, the ribs are cut back to the pans. Rivet roof and wall sheets together. Use butyl tape and silicone to make the joint weathertight. Ensure that the anti-capillary drain on the roof is allowed to drain before the roof/wall joint.

## TYPICAL FLASHING DETAIL

At the high end of the roof run, fascia or ridge flashing is conventional and must cover the cladding by at least 150mm.

Notch the flashing around the ribs and secure with low profile fasteners at approximately 300mm centres.

The barge flashing is also conventional and must cover the cladding by at least one rib. If necessary, support the flashing on roof battens to maintain the flashing shape over wider coverage and secure with low profile fasteners at approximately the same spacing as supports below.

For more flashing detail, refer to the *Stramit® Roof and Wall Flashing Architectural Detailing Design Guide* available on [stramit.com.au](http://stramit.com.au).

# ADDITIONAL INFORMATION

## MAINTENANCE

Exterior surfaces of metal products unwashed by rain can benefit from occasional washing to remove build-up of corrosive salts. Walls beneath eaves or awnings are such a situation.

## FURTHER INFORMATION

As well as our standard range of Technical Manuals, Installation Leaflets, Case Studies and other promotional literature Stramit has a series of Guides to aid design.

## REFERENCES

In preparing this document reference has been made to:

- Standards Australia Handbook – HB39 (Installation code for metal roof and wall cladding)
- BlueScope Steel – Technical Bulletin TB-4 (Maintenance of COLORBOND® pre-painted steel roofing)
- BlueScope Steel – Technical Bulletin TB-1 (Steel roofing and walling products – selection guide)

# CONTACT US

Visit [stramit.com.au](http://stramit.com.au) or contact us using the details below.

REGION	LOCATION	CONTACT DETAILS	TECHNICAL ENQUIRIES
NSW & ACT	SYDNEY 33-83 Quarry Rd, Erskine Park NSW 2759	Ph 02 9834 0909	Ph 02 9834 0964
	CANBERRA 4 Bass St, Queanbeyan NSW 2620	Ph 02 6298 2500	
	COFFS HARBOUR 6 Mansbridge Dr, Coffs Harbour NSW 2450	Ph 02 6656 3800	
	NEWCASTLE 17 Nelson Rd, Cardiff NSW 2285	Ph 02 4041 3400	
	ORANGE 51 Leewood Dr, Orange NSW 2800	Ph 02 6360 9200	
VIC	MELBOURNE 3/1464 Ferntree Gully Rd, Knoxfield VIC 3180	Ph 03 9237 6300	Ph 03 9237 6353
	ALBURY 18 Ariel Dr, Albury NSW 2640	Ph 02 6092 3700	
	BENDIGO Lot 7-9 Ramsay Court, Kangaroo Flat VIC 3555	Ph 03 5448 6400	
TAS	HOBART 57 Crooked Billett Dr, Brighton TAS 7030	Ph 03 6262 8788	Ph 03 9237 6353
SA	ADELAIDE 11 Stock Rd, Cavan SA 5094	Ph 08 8219 2000	Ph 08 9493 8823
SOUTH QLD	BRISBANE 57-71 Platinum St, Crestmead QLD 4132	Ph 07 3803 9999	Ph 07 3803 9869
	MARYBOROUGH 10 Activity St, Maryborough QLD 4650	Ph 07 4123 9500	
	ROCKHAMPTON 41 Johnson St, Parkhurst QLD 4702	Ph 07 4921 5600	
NORTH QLD	CAIRNS 53 Vickers St, Edmonton QLD 4869	Ph 07 4034 6555	Ph 07 3803 9869
	TOWNSVILLE 402-408 Bayswater Rd, Garbutt QLD 4814	Ph 07 4412 3900	
WA	PERTH 605-615 Bickley Rd, Maddington WA 6109	Ph 08 9493 8800	Ph 08 9493 8823

© 2021 Stramit Corporation Pty Limited ABN 57 005 010 195. A member of the Fletcher Building Group. Use of ™ and ® indicates trade marks of Stramit Corporation Pty Limited. This document replaces all previous issues. Please destroy, or clearly mark as superseded, all previous issues. COLORBOND®, Zinalume® and \* colour names are registered trade marks of BlueScope Steel Limited. ™ colour names are trade marks of BlueScope Steel Limited. ABN 16 000 011 058. MagnaFlow® is a registered trademark of Fletcher Building Holdings Limited. Sisalation® is a registered trademark of Fletcher Insulation Pty Ltd. UniCote® is a registered trademark of Selection Steel Trading Pty. Ltd. STR054\_OCT22.