

RAINWATER GOODS - SA

GUTTERS, FASCIA & ACCESSORIES



A Met-TECH™ GUIDE

DECEMBER 2022



Metroll®

BETTER SERVICE • BETTER BUILDING SOLUTIONS

METROLL SA - RAINWATER GOODS

Made from COLORBOND®, ZINCALUME® and galvanised steels, the Metroll SA range of gutters, fascia and accessories are practical and designed to suit the demanding needs of any building and environment.

WIDE RANGE OF APPLICATIONS

Whether you require a standard or custom item, Metroll rainwater goods are available for a wide range of applications across commercial, domestic, industrial or rural buildings.

STYLE & COLOUR CHOICE

Metroll's style, material and colour range is extensive to ensure your rainwater goods are both durable and complementary to your roof and building design.

DOWNPIPES & ACCESSORIES

Metroll SA stocks a range of round and rectangular metal downpipes. PVC downpipes are also available. Check with us for availability and lead times.

MATERIAL & INSTALLATION INFO

MATERIAL COMPATIBILITY

Never use lead flashings with rainwater items made from COLORBOND® and ZINCALUME® steels. Avoid drainage from copper roofs onto COLORBOND®, ZINCALUME® or galvanised steel rainwater products.

ADVERSE CONDITIONS

Localised environmental conditions can impact the corrosive nature of a site which may impact on material choice. Conditions that may impact on material choice include; direction of prevailing winds, rainfall intensity, duration of exposure, temperature, shelter and areas not washed by rainfall. Contact your local Metroll branch if you intend to use any Metroll rainwater goods within 1 km of industrial, chemical, marine or corrosive environments.

MEASUREMENTS & INSTALLATION

Rainwater goods must be installed with special consideration given to roof fall and overall design of the drainage system. Measure along the roof edges to calculate how many sections of gutter are required. Add 10% to allow for fitting and wastage. Combine roof measurements with the gutter layout plan to calculate and assess all other required gutter components.

CLEAN UP

Prior to departing the work site remove all foreign debris, screws, rivets and especially any swarf created by drilling or cutting from the roof surface and/or inside gutters. Failure to do so may result in premature corrosion of the roof and/or gutters.

What is Met-TECH™?

Met-TECH™ is Metroll's Technical Resource Centre. It is the one stop shop for all of Metroll's product and technical information. Perfect for builders, contractors and specifiers to source all the information they may require. You can find other Met-TECH™ items on our website www.metroll.com.au/resources

RAINWATER OVERFLOW DESIGN & PROVISION

When designing a roof drainage system there are a range of factors that must be considered. These include:

- Rainfall intensity
- Roof area
- Gutter size
- Gutter capacity
- Gutter fall
- Downpipe size
- Downpipe quantity
- Downpipe placement
- Overflow systems

The NCC 2016, Part 3.5.2 details the appropriate performance requirements for overflow measures of eave and valley gutters. This has recently been updated and incorporates requirements for rainfall intensities of 1 in 20 years and 1 in a 100 years intervals for locations Australia wide.

CONSTRUCTION & COMPLIANCE

It is important that the drainage system diverts water away from the building. NCC 2016, Part 3.5.2 sets out acceptable construction practices and gives consideration to materials, gutter selection, gutter installation, downpipe size and downpipe installation. The NCC 2016 code also provides information on rainfall duration intensities, overflow volumes and acceptable overflow measures both continuous and dedicated.

OVERFLOW MEASURES & DRAINAGE SYSTEM DESIGN

It is important to note that a combination of overflow measures may be required in order to achieve a drainage system that complies. Overflow systems must be considered in totality of the drainage system as it may not be sufficient to rely on gutter capacity alone.

CLASS 1 DWELLING PROVISION

The NCC requires that eave gutters on Class 1 dwellings be designed to prevent water entry to the building under severe rain conditions. Severe is defined as the 100 year, 5 minute duration average recurrence interval event (100Yr ARI).

DESIGNER RESPONSIBILITY

The designer may be the builder, hydraulic engineer, architect, building designer, roof and guttering contractor or homeowner. In all cases it is up to the designer to design a complete rainwater drainage system that meets the requirements of the NCC Building Code and relevant Australian Standards. Designers should take note of AS/NZS 3500.3 and AS/NZS 3500.5.

Broadly the items for consideration when designing a rainwater drainage system are:

- Ascertain rainfall intensity duration.
- Consider roof design, roof catchment area, slope, downpipe quantity, downpipe position, gutter length and ridge to gutter length.
- Calculate overflow volume.
- Select suitable downpipes, gutters and overflow measures based on overflow volume.

INSTALLER RESPONSIBILITY

The installer is responsible for installing the rainwater drainage system as per the design provided by the designer. The minimum requirements for the installation of gutters is set out in the NCC 2016, Section 3.5.2.4.

HOMEOWNER RESPONSIBILITY

A rainwater drainage system is only as good as the maintenance of the system. Blocked gutters, downpipes or other overflow items will reduce the performance of the drainage system. The homeowner is responsible for ensuring basic maintenance of the drainage system is carried out at regular intervals.

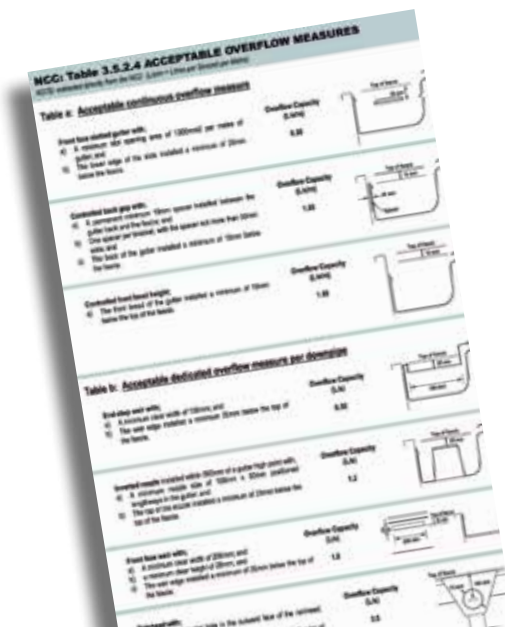

Refer to the NCC 2016, Part 3.5.2 which details the appropriate performance requirements for overflow measures of eave and valley gutters.

RAINWATER OVERFLOW DESIGN & PROVISION

NCC: Table 3.5.2.4 ACCEPTABLE OVERFLOW MEASURES

Note: Extracted directly from the NCC. (L/s/m = Litres per second per metre)

TABLE A: ACCEPTABLE CONTINUOUS OVERFLOW MEASURES

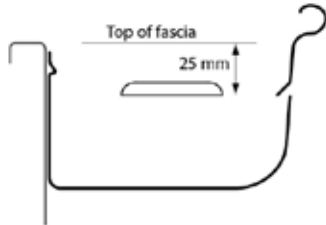
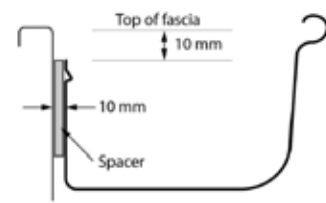
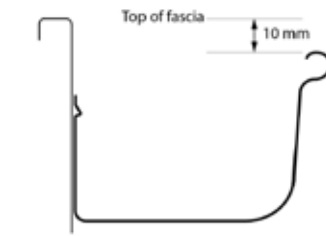

	Overflow Capacity (L/s/m)	
<p>Front face slotted gutter with;</p> <ul style="list-style-type: none"> a. A minimum slot opening area of 1200mm² per metre gutter; and b. The lower edge of the slots is installed a minimum of 25mm below the fascia. 	<p>0.50</p>	
<p>Controlled back gap with;</p> <ul style="list-style-type: none"> a. A permanent minimum 10mm spacer installed between the gutter back and fascia; and b. One spacer per bracket, with the spacer not more than 50mm wide; and c. The back of the gutter installed a minimum of 10mm below the fascia. 	<p>1.50</p>	
<p>Controlled front bead height;</p> <ul style="list-style-type: none"> a. The front bead of the gutter installed a minimum 10mm below the top of the fascia. 	<p>1.50</p>	

RAINWATER OVERFLOW DESIGN & PROVISION

NCC: Table 3.5.2.4 ACCEPTABLE OVERFLOW MEASURES

Note: Extracted directly from the NCC. (L/s/m = Litres per second per metre)

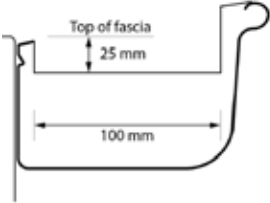
TABLE B: ACCEPTABLE DEDICATED OVERFLOW MEASURES PER DOWNPIPE

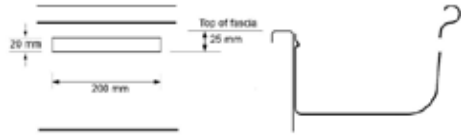
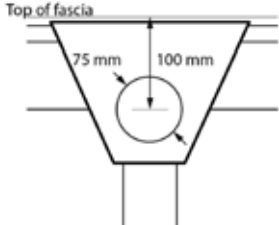
	Overflow Capacity (L/s)	
<p>End-stop weir with;</p> <p>a. A minimum clear width of 100mm; and</p> <p>b. The weir edge installed a minimum of 25mm below the fascia.</p>	0.50	
<p>Inverted nozzle installed within 500mm of a gutter high point with;</p> <p>a. A minimum nozzle size of 100mm x 50mm positioned lengthways in the gutter; and</p> <p>b. The top of the nozzle installed a minimum of 25mm below the top of the fascia.</p>	1.2	
<p>Front race weir with;</p> <p>a. A minimum clear width of 200mm; and</p> <p>b. A minimum clear height of 20mm; and</p> <p>c. The weir edge installed a minimum of 25mm below the top of the fascia.</p>	1.0	
<p>Rainhead with;</p> <p>a. A 75mm diameter hole in the outward face of the rainhead; and</p> <p>b. The centreline of the hole positioned 100mm below the top of the fascia.</p>	3.5	

GUTTER RANGE & SPECIFICATION

TCA: Total Cross Sectional Area.
ECA: Effective Cross Sectional Area.
 ECA is 10mm below the overflow level.

115 QUAD GUTTER

	Standard
ECA mm²	5,611
TCA mm²	4,673

A popular profile. The high front provides for a great aesthetic finish to any project.

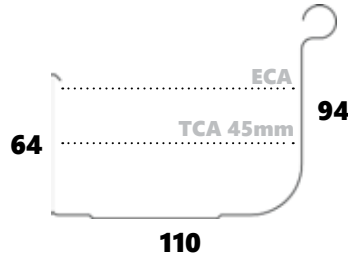

125 QUAD GUTTER

	Standard
ECA mm²	7,177
TCA mm²	5,564

A popular profile. The high front provides for a great aesthetic finish to any project.

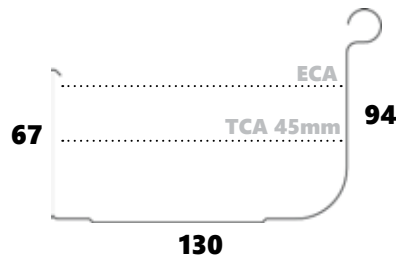

150 QUAD GUTTER

	Standard
ECA mm²	8,889
TCA mm²	6,902

A popular profile. The high front provides for a great aesthetic finish to any project.

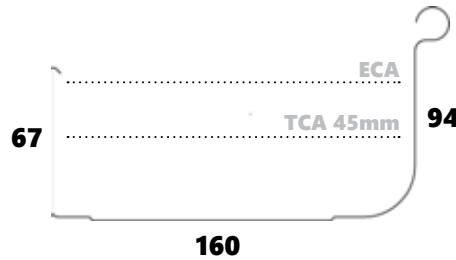

METROLINE GUTTER

	Standard
ECA mm²	7,331
TCA mm²	6,071

Designed with a high front to hide the edges of roof sheets or tiles, this gutter is easily suited to new projects or renovations.

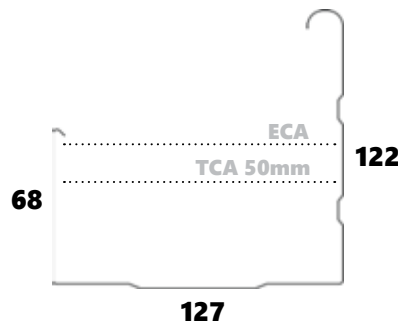

OG GUTTER

	Standard
ECA mm²	5,209
TCA mm²	4,834

Metroll's traditional colonial style gutter. This gutter is particularly well suited to traditional designs.

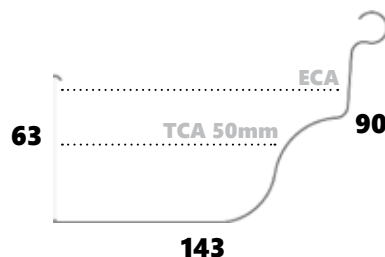

CITY GUTTER

	Standard
ECA mm ²	11,246

A contemporary style with larger water carrying capacity for a modern home. No slots.

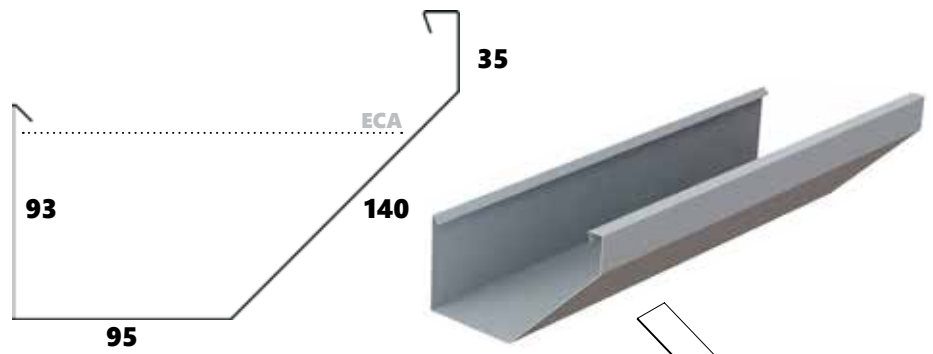

LARGE CITY GUTTER BRACKET

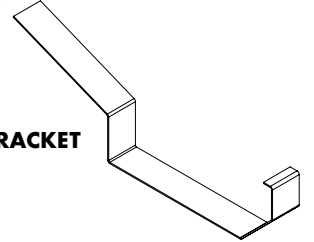

SUBURBAN GUTTER

	Standard
ECA mm ²	7,502

A smaller version of the popular City Gutter suited to smaller roof areas and tight boundaries. No slots.

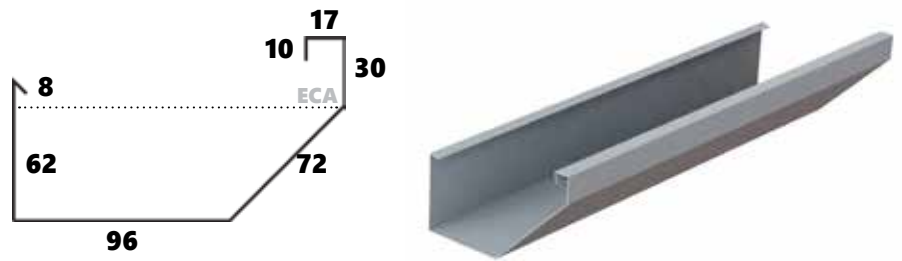

FASCIA & RIDGE CAP

FASCIA

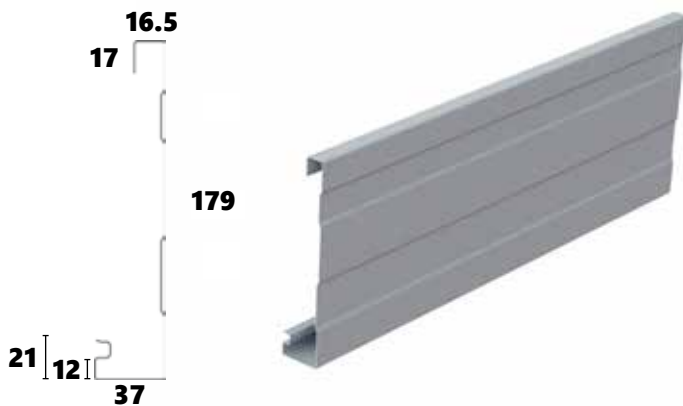

FASCIA COVER

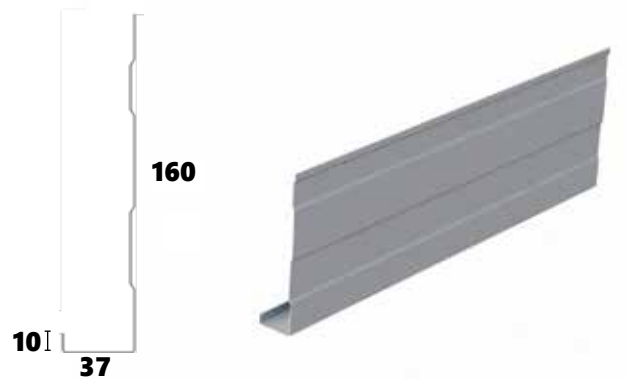

RIDGE CAP

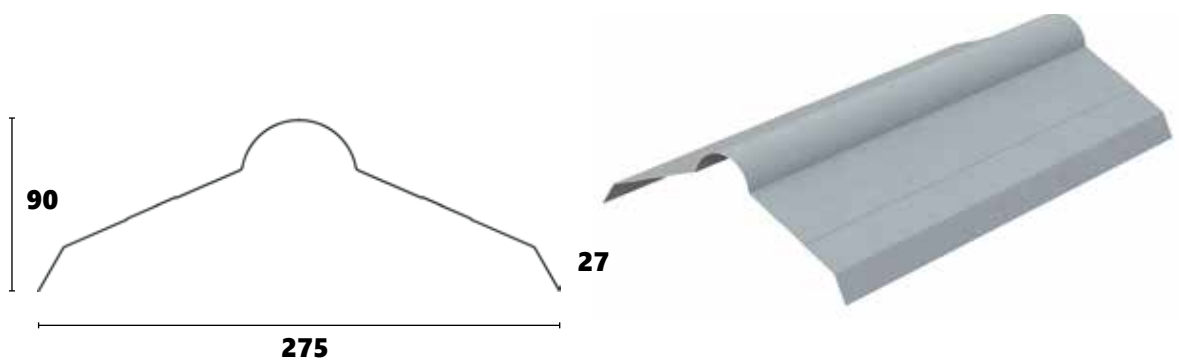

Can we assist with any additional
Steel Building Products?



Metroll Adelaide
Phone: 08 8282 3300
70 - 72 Rundle Road
Salisbury South, SA 5106

Visit our website
metroll.com.au



All reasonable care has been taken in the compilation of the information contained in this brochure. All recommendations on the use of Metroll products are made without guarantee as conditions of use are beyond the control of Metroll. It is the customers responsibility to ensure that the product is fit for its intended purpose and that the actual conditions of use are suitable. Metroll pursues a policy of continuous development and reserves the right to amend specifications without prior notice. The Metroll M and Logo are registered trademarks of Metroll. COLORBOND®, ZINCALUME®, GALVSPAN® steels are all registered trademarks of BlueScope Steel Limited.