

# DESIGNING FOR WIND SPEEDS

GUIDE TO WIND CLASSIFICATION



A Met-TECH™ GUIDE

SEPTEMBER 2020



**Metroll**®

BETTER SERVICE • BETTER BUILDING SOLUTIONS

# DESIGNING FOR WIND SPEEDS

The information in this guide is based on Australian Standard AS4055-2012 Wind loads for housing, and is intended as a guide only. For full and complete details please refer to AS4055-2012 Wind loads for housing and AS/NZS 1170.2:2011 Structural design actions. Part 2: Wind actions.

This guide provides information to assist in determining the wind speed classifications for domestic buildings.

It is applicable to domestic buildings (Class 1 and 10 as defined by the NCC Code) that are:

- No wider than 16m,
- No higher than 8.5m (ground level to highest point in the roof excluding chimneys) and,
- Have a roof pitch that does not exceed 35°.

## How is Wind Classification determined?

Establishing the wind speed classification for a house requires the following site conditions to be established:

1. Geographic Wind Speed Region
2. Terrain Category
3. Topographic Classification
4. Shielding Class

## GEOGRAPHIC WIND SPEED REGIONS

Identify what region the dwelling is in.

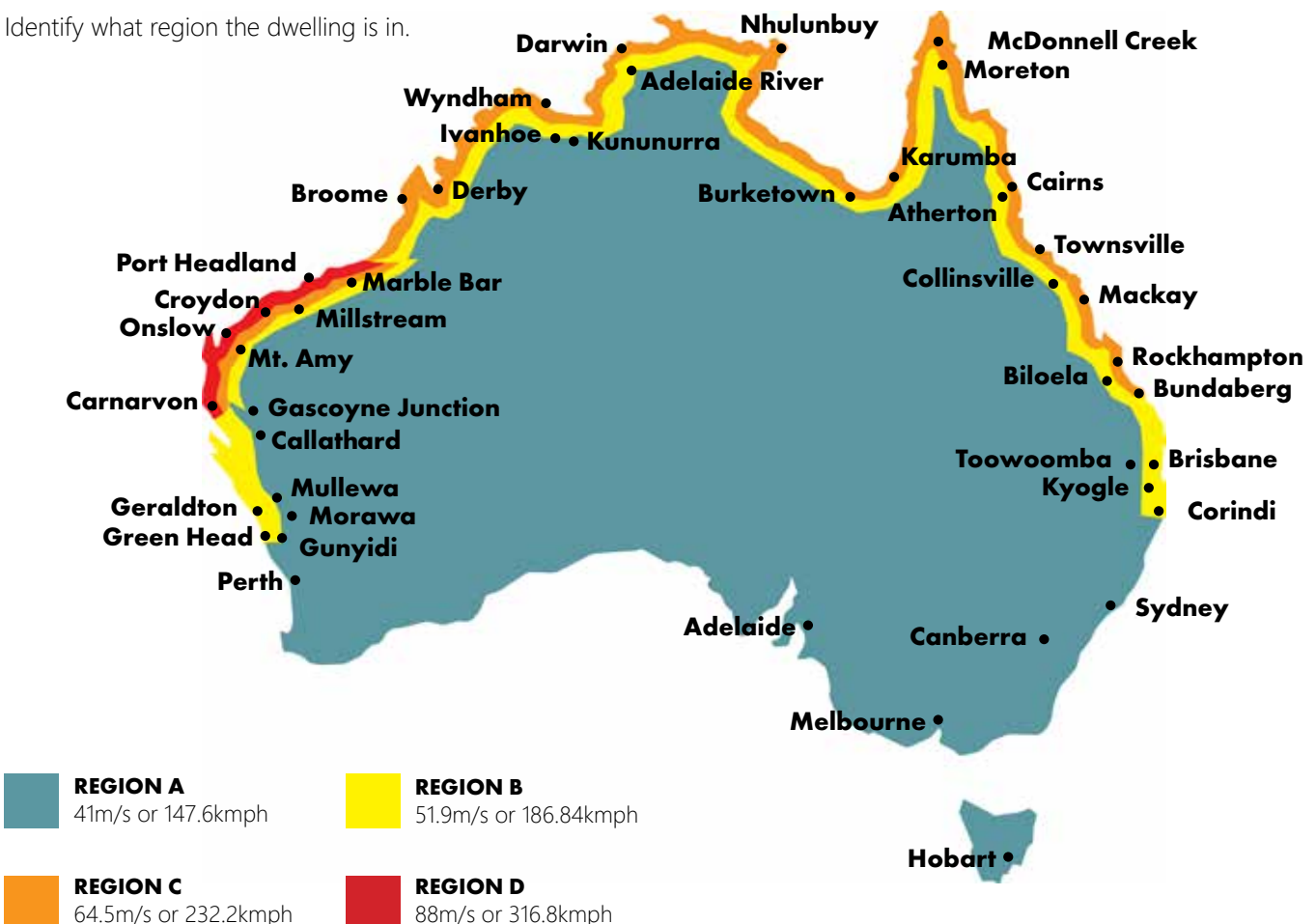

## TERRAIN CATEGORY

---

The terrain category describes the surface roughness of the surrounding area 500m from the housing site. Select from the below categories:

### TC1 TERRAIN CATEGORY 1



Very exposed open terrain with few or no obstructions and enclosed limited sized water surfaces, e.g. flat, treeless, poorly grassed plains, or river, canals, lakes and enclosed bays, extending less than 10km in the wind direction.

### TC1.5 TERRAIN CATEGORY 1.5



Open water surfaces subject to shoaling waves, e.g. near shore water, large unenclosed bays on seas and oceans, lakes and enclosed bays extending greater than 10km in the wind direction.

### TC2 TERRAIN CATEGORY 2



Open terrain including grassland with well-scattered obstructions having heights generally from 1.5m to 5m with no more than 2 obstructions per hectare, e.g. farmland and cleared subdivisions with isolated trees and uncut grass.

### TC2.5 TERRAIN CATEGORY 2.5



Terrain with few trees or isolated obstructions. This category is intermediate between TC2 and TC3 and represents the terrain in developing outer urban areas with scattered houses, or large acreage developments with fewer than 10 buildings per hectare.

### TC3 TERRAIN CATEGORY 3



Terrain with numerous closely spaced obstructions having heights generally from 3m to 10m. The minimum density of obstructions shall be at least the equivalent of 10 house-size obstructions per hectare, e.g. suburban housing, light industrial estates or dense forest.

## TOPOGRAPHIC CLASSIFICATIONS

---

The topographic classification is determined by the effect the wind has on the dwelling due to its possible position on a hill, ridge or escarpment and the height and maximum slope of the hill, ridge or escarpment.

The bottom of a hill, ridge or escarpment is the area at the base where the average slope is less than 1 in 20.

The maximum slope is the point where the hill, ridge or escarpment is at its steepest. This is factored in regardless of where the house is positioned. The top third zone extends for equal distance either side of the top of a hill, ridge or escarpment.

Topographic classifications are broken into zones T0, T1, T2, T3, T4 and T5. Use the table following to determine the topographic class of a dwelling located on a hill, ridge or escarpment.

## TOPOGRAPHIC CLASSIFICATION TABLE

**SITE LOCATION ON HILL/RIDGE/ESCARPMENT**



MAXIMUM SLOPE OF HILL	LOWER THIRD	MID THIRD	TOP THIRD			OVER TOP*
Less than 1:20 (2.9°)	T0	T0	T0	T0	T0	T0
Greater than and equal to 1:20 <b>to</b> Less than 1:10 (≥ 2.9° to < 5.7°)	T0	T0	T1	T1	T1	T0
Greater than and equal to 1:10 <b>to</b> Less than 1:7.5 (≥ 5.7° to < 7.6°)	T0	T1	T1	T2	T2	T0
Greater than and equal to 1:7.5 <b>to</b> Less than 1:5 (≥ 7.6° to < 11.3°)	T0	T1	T2	T2	T3	T1
Greater than and equal to 1:5 <b>to</b> Less than 1:3 (≥ 11.3° to < 18.4°)	T0	T2	T2	T3	T4	T2
Greater than and equal to 1:3 (18.4°)	T0	T2	T3	T4	T5	T3

\* Applies to 4 times the height past the crest for escarpments only.

## SHIELDING CLASS

The Shielding Class of a dwelling identifies how the wind speeds on a house are influenced by obstructions of a similar size. Shielding should be based on likely shielding 5 years hence. The Shielding Classes are as follows:

### FS FULL SHIELDING

Full Shielding applies where at least two rows of houses or similar size permanent obstructions surround the house. In Wind Regions A and B, permanent, closely-spaced trees with a height greater than the proposed house, and extending equivalent to three rows of houses, is considered Full Shielding. Full Shielding is only possible for houses within Topographic Classes T0, T1 and T2. The Full Shielding Class is applicable to suburban developments with 10 or more houses, or similar sized obstructions, per hectare. The effects of roads or other open areas with a distance of 100m in any direction are exempt. However, the first two rows of houses abutting permanent open areas with a minimum of 100m, such as parklands, large expanses of water and airfields, are considered to be either Partial Shielding or No Shielding classes.

### PS PARTIAL SHIELDING

Partial Shielding applies to intermediate situations where there are at least 2.5 houses or sheds per hectare, such as acreage type suburban development. In Wind Regions A and B, permanent, closely-spaced trees with a height greater than the proposed house, and extending equivalent to two rows of houses, is considered Partial Shielding. Partial Shielding is only possible for houses within Topographic Classes T0, T1, T2 and T3. The second row of houses abutting parkland, open water or airfields, are classified as Partial Shielding.

### NS NO SHIELDING

No Shielding applies where there are no permanent obstructions or where there are less than 2.5 obstructions per hectare, such as the row of houses or single houses abutting parkland, open water or airfields.

# DETERMINING THE WIND CLASSIFICATION

The Wind Classification is a combination of Wind Region, Terrain Category, Topography & Shielding. AS4055-2012 identifies 10 Wind Classes: N1 -N6 and C1 - C4.

Use the table below to determine this Wind Classification. Once the Wind Classification is determined, and by working in accordance with AS4055.2012, the wind loads design requirements for a dwelling can be established.

WIND REGION	TERRAIN CATEGORY	T0			T1			T2			T3		T4	T5	TOPOGRAPHIC CLASS	
		FS	PS	NS	FS	PS	NS	FS	PS	NS	PS	NS	NS	NS	SHIELDING CLASS	
A	3	N1	N1	N1	N1	N2	N2	N2	N2	N2	N3	N3	N3	N4	NON-CYCLONIC (N)	
	2.5	N1	N1	N2	N1	N2	N2	N2	N3	N3	N3	N3	N4	N4		
	2	N1	N2	N2	N2	N2	N3	N2	N3	N3	N3	N3	N4	N4		
	1.5	N2	N2	N2	N2	N3	N3	N3	N3	N3	N3	N4	N4	N5		
	1	N2	N3	N3	N2	N3	N3	N3	N3	N4	N3	N4	N4	N5		
B	3	N2	N2	N3	N2	N3	N3	N3	N3	N4	N4	N4	N4	N5		NON-CYCLONIC (N)
	2.5	N2	N3	N3	N3	N3	N3	N3	N4	N4	N4	N4	N5	N5		
	2	N2	N3	N3	N3	N3	N4	N3	N4	N4	N4	N5	N5	N6		
	1.5	N3	N3	N4	N3	N4	N4	N4	N4	N4	N5	N5	N5	N6		
	1	N3	N4	N4	N4	N4	N4	N4	N5	N5	N5	N5	N6	N6		
C	3	C1	C1	C2	C1	C2	C2	C2	C2	C3	C3	C3	C3	C4	CYCLONIC (C)	
	2.5	C1	C2	C2	C2	C2	C2	C2	C3	C3	C3	C3	C4	NA		
	2	C1	C2	C2	C2	C2	C3	C2	C3	C3	C3	C4	C4	NA		
	1.5	C2	C2	C3	C2	C3	C3	C3	C3	C4	C4	C4	NA	NA		
	1	C2	C3	C3	C3	C3	C3	C3	C4	C4	C4	NA	NA	NA		
D	3	C2	C3	C3	C2	C3	C3	C3	C4	C4	C4	C4	NA	NA		CYCLONIC (C)
	2.5	C2	C3	C3	C3	C3	C4	C3	C4	C4	C4	NA	NA	NA		
	2	C3	C3	C4	C3	C4	C4	C4	C4	NA	NA	NA	NA	NA		
	1.5	C3	C4	C4	C4	C4	NA	C4	NA	NA	NA	NA	NA	NA		
	1	C3	C4	C4	C4	NA	NA	NA	NA	NA	NA	NA	NA	NA		

NA = Not available. Refer to AS4055.2012 Table 2.2

## FURTHER INFORMATION FOR DESIGNERS

### DESIGN GUST WIND SPEED FOR NON-CYCLONIC REGIONS A & B

WIND CLASS	COMMON NOTATION	DESIGN GUST WIND SPEED ( $V_h$ ) AT HEIGHT (h) m/s	
		Serviceability Limit State ( $V_{h,s}$ )	Ultimate Limit State ( $V_{h,u}$ )
N1	W28	26	34
N2	W33	26	40
N3	W41	32	50
N4	W50	39	61
N5	W60	47	74
N6	W70	55	86

## DESIGN GUST WIND SPEED FOR CYCLONIC REGIONS C & D

WIND CLASS	COMMON NOTATION	DESIGN GUST WIND SPEED ( $V_h$ ) AT HEIGHT (h) m/s	
		Serviceability Limit State ( $V_{h,s}$ )	Ultimate Limit State ( $V_{h,u}$ )
C1	W41C	32	50
C2	W50C	39	61
C3	W60C	47	74
C4	W70C	55	86

### PRESSURE ZONES ON ROOFS (PLAN VIEW)

The following external pressure zones shall be used in evaluating wind loads on houses:

- General (G)** Areas of roofs more than 1200mm from edges, and areas of walls (including windows and doors) more than 1200mm from external corners.
- Roof Edge (RE)** Areas of roofs within 1200mm of all edges except the external corners of the roof.
- Roof Corners (RC)** Areas of the external corners of roofs within 1200mm of two adjacent edges. (This is the overlap between two RE zones.)
- Walls Near Corners (SC)** Walls (including windows and doors) at external corners of the house within 1200mm of the corner.

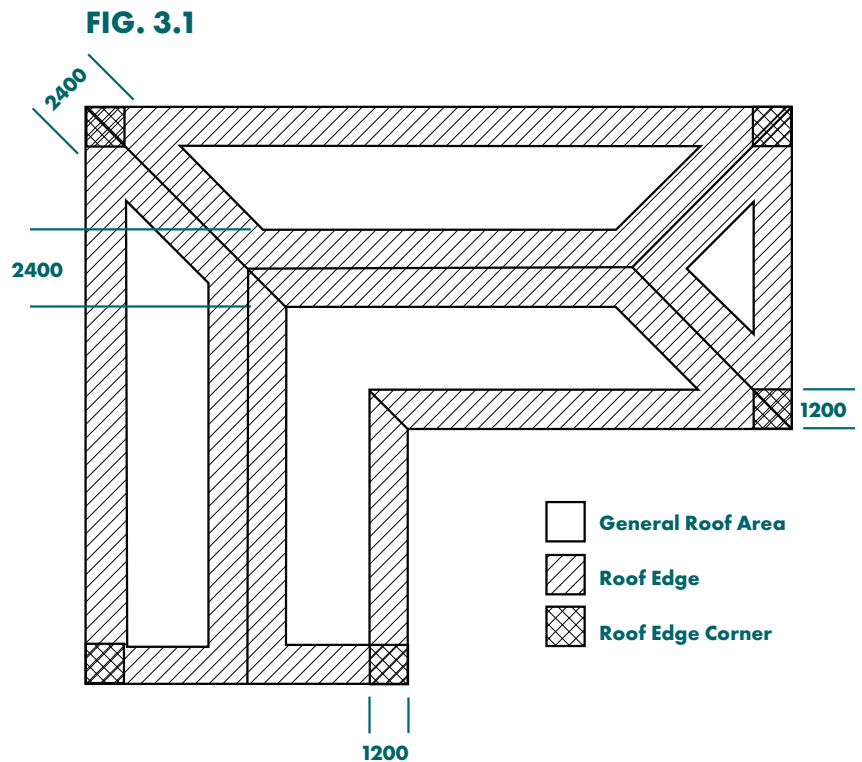

### PRESSURE ZONES ON WALLS (PLAN VIEW)

**FIG. 3.2**

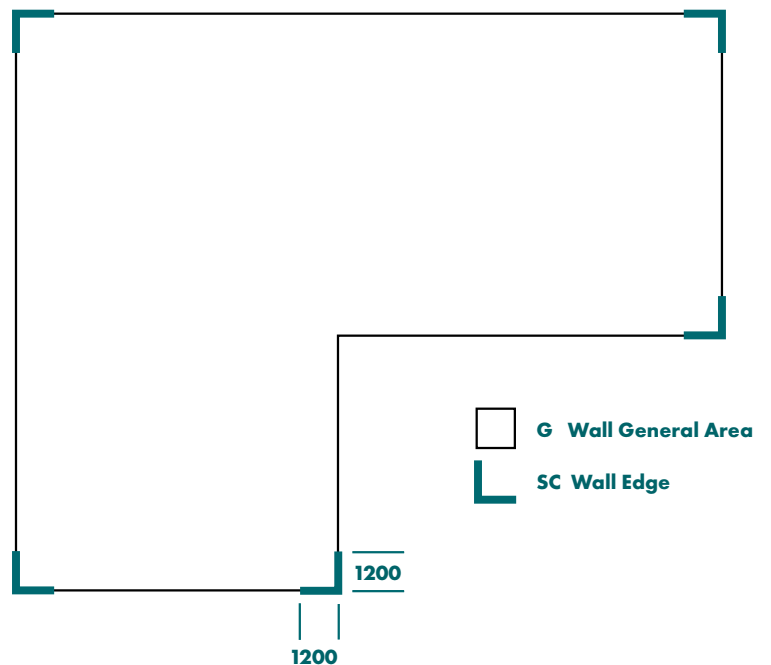

## ULTIMATE STRENGTH PRESSURES (kPa) FOR WIND CLASSIFICATION FROM THE NET PRESSURE COEFFICIENTS GIVEN IN CLAUSE 3.2 (AS 4055-2012)

WIND CLASS	WALLS - Refer FIG. 3.2			ROOFS - Refer FIG. 3.1			
	Any Position	Away from Corners (see Note 3)	Within 1200mm of Corners (see Note 3)	Any Position	General Away from Edges (see Note 2)	Within 1200mm of Edges (see Note 2)	At Corners - Within 1200mm of both Edges (see Note 2)
<b>PRESSURE ZONE</b>	<b>G, SC</b>	<b>G</b>	<b>SC</b>	<b>G, RE, RC</b>	<b>G</b>	<b>RE</b>	<b>RC</b>
<b><math>K_c C_{p,n}</math></b>	<b>+0.9</b>	<b>-0.77</b>	<b>-1.35</b>	<b>+0.63</b>	<b>-0.99</b>	<b>-1.8</b>	<b>-2.61</b>
N1	+0.62	-0.53	-0.94	+0.44	-0.69	-1.25	-1.81
N2	+0.86	-0.74	-1.30	+0.60	-0.95	-1.73	-2.51
N3	+1.35	-1.16	-2.03	+0.95	-1.49	-2.70	-3.92
N4	+2.01	-1.72	-3.01	+1.41	-2.21	-4.02	-5.83
N5	+2.96	-2.53	-4.44	+2.07	-3.25	-5.91	-8.58
N6	+3.99	-3.42	-5.99	+2.80	-4.39	-7.99	-11.58
<b><math>K_c C_{p,n}</math></b>	<b>+1.2</b>	<b>-1.2</b>	<b>-1.8</b>	<b>+0.95</b>	<b>-1.44</b>	<b>-2.25</b>	<b>-3.06</b>
C1	+1.80	-1.80	-2.7	+1.43	-2.16	-3.38	-4.59
C2	+2.68	-2.68	-4.02	+2.12	-3.21	-5.02	-6.83
C3	+3.94	-3.94	-5.91	+3.12	-4.73	-7.39	-10.05
C4	+5.33	-5.33	-7.99	+4.22	-6.39	-9.98	-13.58

### NOTES:

1. All locations must be able to resist both positive and negative net pressures. The positive net pressures apply to any position on the surface. The negative net pressures are given for each pressure zone defined in Clause 3.1 and illustrated for roofs in Figure 3.1 and for walls in Figure 3.2.
2. For roofs, net pressures on cladding, fasteners and immediate supporting members (such as battens and purlins) are specific to the pressure zone. Net pressure effects on trusses and rafters can be taken from the net pressures for general zones.
3. For walls, net pressures on cladding elements and fasteners (such as wall sheathing, windows and doors) are specific to the pressure zone. Net pressure effects on wall studs and frames can be taken from the net pressures for general zones.
4. The design net pressures for eaves and soffit linings is taken as equal to the net pressures applied to adjacent wall surface (e.g. the design pressure for eaves lining within 1200mm of a corner for a C2 classification is +2.68 kPa and -4.02 kPa).
5. The net pressures for all N wind classifications may only be used where all cladding elements including windows demonstrate compliance with the relevant Australian Standard.
6. In order to use the internal pressures in the N classifications in this table, all of the cladding elements including windows, doors and garage doors need to be designed to resist the design winds.

## SERVICEABILITY PRESSURES (kPa) FOR WIND CLASSIFICATION FROM THE NET PRESSURE COEFFICIENTS GIVEN IN CLAUSE 3.2 (AS 4055-2012)

WIND CLASS	WALLS - Refer FIG. 3.2			ROOFS - Refer FIG. 3.1			
	Any Position	Away from Corners (see Note 3)	Within 1200mm of Corners (see Note 3)	Any Position	General Away from Edges (see Note 2)	Within 1200mm of Edges (see Note 2)	At Corners - Within 1200mm of both Edges (see Note 2)
PRESSURE ZONE	G, SC	G	SC	G, RE, RC	G	RE	RC
<b>K<sub>c</sub> C<sub>p,n</sub></b>	<b>+0.9</b>	<b>-0.77</b>	<b>-1.35</b>	<b>+0.63</b>	<b>-0.99</b>	<b>-1.8</b>	<b>-2.61</b>
N1 <sub>serv</sub>	+0.37	-0.31	-0.55	+0.26	-0.40	-0.73	-1.06
N2 <sub>serv</sub>	+0.37	-0.31	-0.55	+0.26	-0.40	-0.73	-1.06
N3 <sub>serv</sub>	+0.55	-0.47	-0.83	+0.39	-0.61	-1.11	-1.60
N4 <sub>serv</sub>	+0.82	-0.70	-1.23	+0.57	-0.90	-1.64	-2.38
N5 <sub>serv</sub>	+1.19	-1.02	-1.79	+0.84	-1.31	-2.39	-3.46
N6 <sub>serv</sub>	+1.63	-1.40	-2.45	+1.14	-1.80	-3.27	-4.74
<b>K<sub>c</sub> C<sub>p,n</sub></b>	<b>+0.9</b>	<b>-0.77</b>	<b>-1.35</b>	<b>+0.61</b>	<b>-0.99</b>	<b>-1.8</b>	<b>-2.61</b>
C1 <sub>serv</sub>	+0.55	-0.47	-0.83	+0.39	-0.61	-1.11	-1.60
C2 <sub>serv</sub>	+0.82	-0.70	-1.23	+0.57	-0.90	-1.64	-2.38
C3 <sub>serv</sub>	+1.19	-1.02	-1.79	+0.84	-1.31	-2.39	-3.46
C4 <sub>serv</sub>	+1.63	-1.40	-2.45	+1.14	-1.80	-3.27	-4.74

### NOTES:

1. All locations are subject to both positive and negative net pressures. The positive net pressures apply to any position on the surface. The negative net pressures are given for each pressure zone defined in Clause 3.1 (AS4055.2012) and illustrated for roofs in Figure 3.1 and for walls in Figure 3.2.
2. For roofs, net pressures on cladding, fasteners and immediate supporting members (such as battens and purlins) are specific to the pressure zone. Net pressure effects on trusses and rafters can be taken from the net pressures for general zones.
3. For walls, net pressures on cladding elements and fasteners (such as wall sheathing, windows and doors) are specific to the pressure zone. Net pressure effects on wall studs and frames can be taken from the net pressures for general zones.
4. The design net pressures for eaves and soffit linings is taken as equal to the net pressures applied to adjacent wall surface.
5. The net pressures for all N wind classifications may only be used where all cladding elements including windows demonstrate compliance with the relevant Australian Standard.

Visit our website  
[metroll.com.au](http://metroll.com.au)



All reasonable care has been taken in the compilation of the information contained in this brochure. All recommendations on the use of Metroll products are made without guarantee as conditions of use are beyond the control of Metroll. It is the customers responsibility to ensure that the product is fit for its intended purpose and that the actual conditions of use are suitable. Metroll pursues a policy of continuous development and reserves the right to amend specifications without prior notice. The Metroll M and Logo are registered trademarks of Metroll. COLORBOND®, ZINCALUME®, GALVSPAN® steels are all registered trademarks of BlueScope Steel Limited.