

CEILING BATTENS, ROOF BATTENS & TOP HATS

DESIGN MANUAL



A Met-TECH™ GUIDE

MAY 2023



Metroll®

BETTER SERVICE • BETTER BUILDING SOLUTIONS

CONTENTS

	Page
DESIGN & SPECIFICATION	3
1. APPLICATION	3
2. MATERIAL	3
GENERAL INFORMATION & INSTALLATION	4
3. MATERIAL COMPATIBILITY	4
4. WELDING	4
5. CUTTING	4
6. WALKING	4
7. BATTEN SPACINGS	4
8. GENERAL FIXING	4
9. ADVERSE CONDITIONS	4
10. ON-SITE STORAGE	4
11. GOOD PRACTICE	4
12. LAPS & ENDS	5
13. ALLOWANCE AT ENDS	5
PRODUCT RANGE & PROPERTIES	6
LIMIT STATE CAPACITY TABLES	8

What is Met-TECH™ ?

Met-TECH™ is Metroll's Technical Resource Centre. It is the one stop shop for all of Metroll's product and technical information. Perfect for builders, contractors and specifiers to source all the information they may require. You can find other Met-TECH items on our website

www.metroll.com.au/resources

CEILING BATTENS, ROOF BATTENS & TOP HATS

Metroll manufacture ceiling battens, roof battens and top hats suited to a variety of residential, commercial and industrial applications. Manufactured from high-tensile galvanised steel and G550, AZ150 ZINCALUME® steel conforming to AS 1397.



FEATURES & BENEFITS

- Wide range of applications
- Big spans
- Range of gauges
- Simple screw fasteners
- Quick to install
- Available in both ZINCALUME® & galvanised steels

DESIGN & SPECIFICATION

APPLICATION

Metroll battens and top hats are suitable for use in residential, commercial and industrial applications when used as a secondary member supporting roof or wall cladding.

AUSTRALIAN STANDARDS

The span tables in this manual have been designed in accordance with the following relevant Australian Standards:

AS 1170.0:2011, AS 1170.1:2002 & AS 1170.2:2011 - Loading Codes

AS/NZS 4600:2005 - Cold-formed Steel Structures

AS 3623:1993 - Domestic Metal Framing

AS 1397:2011 - Steel Sheet & Strip - G550 MPa Steel

AS 1562.1:2018 - Design and installation of sheet roof and wall cladding

ROOF & CEILING BATTENS

Designed in accordance with AS 4055 Wind Loads for Housing.

TOP HATS

Span tables have been produced in combination with calculations derived from AS/NZS 4600 and using software developed by the Centre for Advanced Structural Engineering at the University of Sydney. This software is based on the limit-states from AS/NZS 4600 Cold-formed Steel Structures.

GENERAL INFORMATION & INSTALLATION

MATERIAL COMPATIBILITY

Never use ceiling battens, roof battens or top hats on or in conjunction with lead, copper, bare metal, stainless steel, mortar, concrete, green and some chemically treated timbers. Contact Metroll for more detailed information.

WELDING

Metroll does not recommend the welding of top hats and battens. The heat produced when welding will affect the material properties of the high-tensile, cold-formed steel. In many instances considerable stress concentrations are likely to arise. In addition, welding will remove the galvanised coating locally leading to potential reduction in durability.

CUTTING

Should cutting be required, use a power saw with a steel cutting blade or a power nibbler. Avoid the use of abrasive discs as these can cause burred edges.

WALKING

TOP HATS & ROOF CEILING BATTENS

Ceiling battens are not to be walked on or carry any other loads.

TOP HATS & ROOF BATTENS

Metroll top hat sections and roof battens have been designed to withstand foot traffic load during installation and service.

BATTEN SPACINGS

Restrictions on roof and ceiling batten spacings are subject to roof sheeting capacity, roof tile spacings and support (truss spacing) along with manufacturer's specifications for plasterboard support.

Additional roof battens may be required where local pressure factors are increased due to combined external and internal wind pressures as per AS 1170.2.

GENERAL FIXING

Fix top hats and battens as per the design engineer's requirements or as specified in this manual. Always use the correct fastener type as nominated by the design engineer or as specified in this manual.

ADVERSE CONDITIONS

Localised environmental conditions can impact the corrosive nature of a site which may impact on material choice. Contact your local Metroll branch if you intend to use Metroll ceiling battens, roof battens or top hats within 1 km of industrial, chemical, marine or corrosive environments.

STORAGE & HANDLING

If not required for immediate use, Metroll top hats and battens should be neatly stacked clear of the ground. For extended outdoor storage duration, items should be stored with a small incline so that water does not pool.

Top hats and battens should not be left exposed in the open for extended periods of time. If unavoidable protect from moisture and rain with waterproof covers.

GOOD PRACTICE

Metroll recommends that good trade practice is followed, such as that found in Australian Standards Handbook HB39.

LAPS & ENDS

For a lap to be considered structural a minimum overlap length of 15% of the span (support spacing) is required, i.e. 7.5% at each end. In addition to the two screws at the support position, two additional screws per side are required 25 - 50mm from both ends of the lap at the top of the web and bottom flange, a total of ten screws per lap.

Top hat overlaps (or non-structural laps) are recommended to be a minimum of 100mm in length. In these cases structural continuity must not be assumed. When connecting overlapping top hats, place foot onto upper section to nest sections prior to and during fixing. Laps must be fastened through both webs as shown.

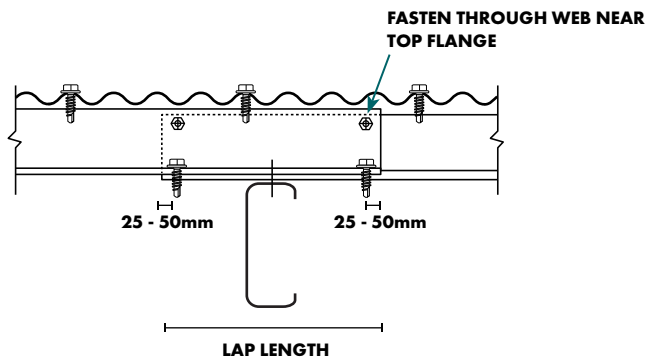

ALLOWANCE AT ENDS

End fastenings are recommended to be at least 25mm from the section end irrespective of whether this occurs at the structure end or at an internal support. Remember to allow this additional material over and above the span length and laps when specifying, ordering or cutting sections.

TYPICAL CONNECTION DETAILS

STRUCTURAL LAP - 2 SCREW CONNECTION

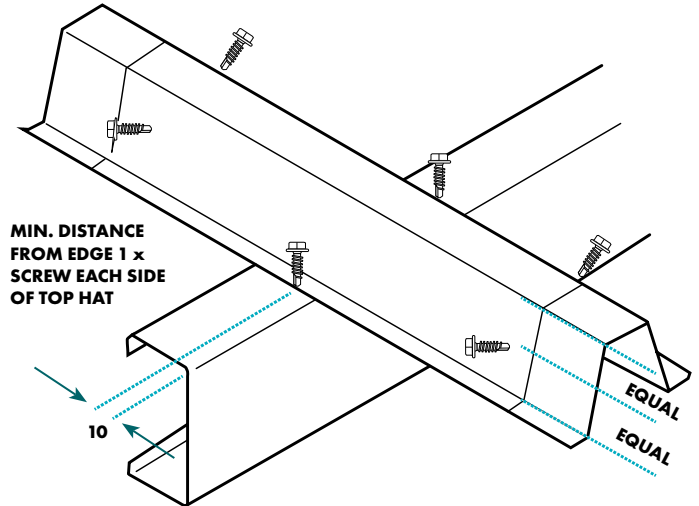

STRUCTURAL LAP - 4 SCREW CONNECTION

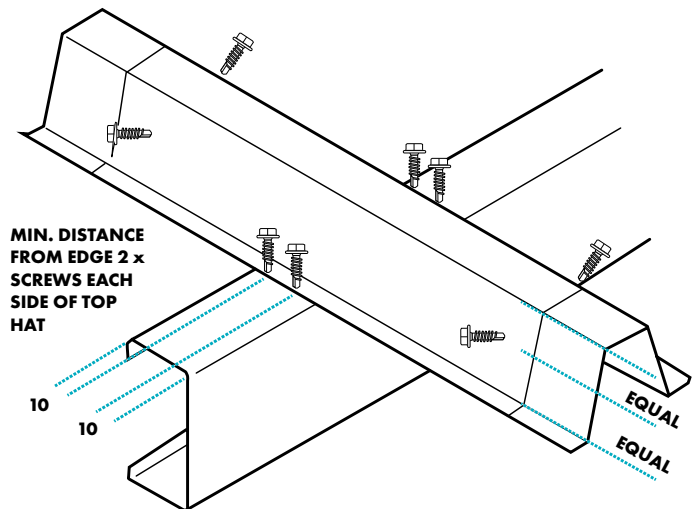

NON-STRUCTURAL LAP

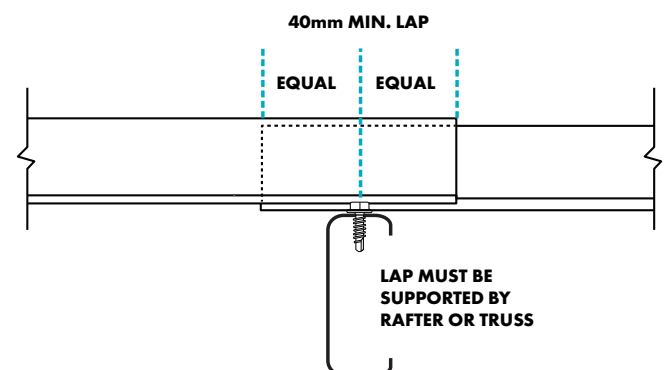

PRODUCT RANGE

22mm CEILING BATTEN

0.42 BMT

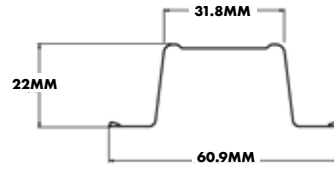

40mm ROOF BATTEN

0.55 BMT

0.75 BMT

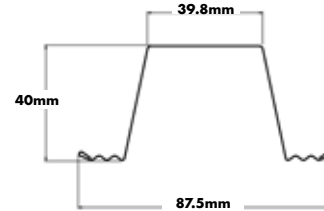

64mm TOP HAT

0.75 BMT

0.95 BMT

1.15 BMT

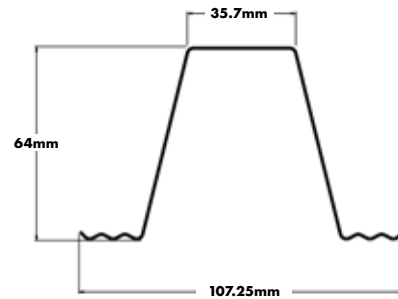

96mm TOP HAT

0.75 BMT

0.95 BMT

1.15 BMT

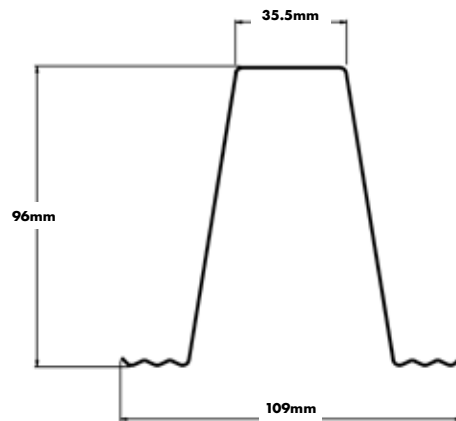

120mm TOP HAT

0.75 BMT

0.95 BMT

1.15 BMT

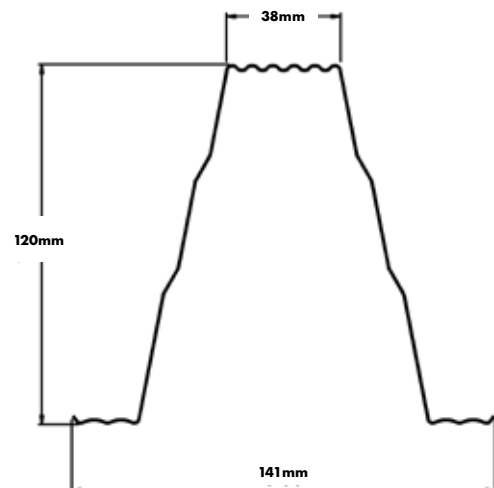

PRODUCT PROPERTIES

22mm CEILING BATTEN FULL SECTION PROPERTIES

SECTION	Nominal Height (mm)	BMT (mm)	Area (mm ²)	Mass (kg/m)	I _x (10 ² mm ⁴)	I _y (10 ² mm ⁴)	Z _{x,top} (10 ² mm ³)	Z _{x,bottom} (10 ² mm ³)	Z _y (10 ² mm ³)	r _x (mm)	r _y (mm)	J (mm ⁴)	B _x (mm)	I _w (10 ⁶ mm ⁴)
22 - 42	22	0.42	40.18	0.32	3.088	12.13	0.269	0.261	0.397	8.77	17.38	2.363	-57.58	0.291

40mm ROOF BATTEN FULL SECTION PROPERTIES

SECTION	Nominal Height (mm)	BMT (mm)	Area (mm ²)	Mass (kg/m)	I _x (10 ² mm ⁴)	I _y (10 ² mm ⁴)	Z _{x,top} (10 ² mm ³)	Z _{x,bottom} (10 ² mm ³)	Z _y (10 ² mm ³)	r _x (mm)	r _y (mm)	J (mm ⁴)	B _x (mm)	I _w (10 ⁶ mm ⁴)
40 - 55	40	0.55	85.35	0.714	21.04	53.99	1.097	1.038	1.228	15.207	24.360	8.606	-90.57	3.475
40 - 75	40	0.75	115.20	0.974	28.46	71.25	1.471	1.416	1.635	15.146	23.965	21.71	-89.54	4.608

64mm TOP HAT FULL SECTION PROPERTIES

SECTION	Nominal Height (mm)	BMT (mm)	Area (mm ²)	Mass (kg/m)	I _x (10 ² mm ⁴)	I _y (10 ² mm ⁴)	Z _{x,top} (10 ² mm ³)	Z _{x,bottom} (10 ² mm ³)	Z _y (10 ² mm ³)	r _x (mm)	r _y (mm)	J (mm ⁴)	B _x (mm)	I _w (10 ⁶ mm ⁴)
64 - 75	64	0.75	155.30	1.223	87.82	129.1	2.681	2.681	2.431	23.743	28.788	29.12	-118.10	17.90
64 - 100	64	0.95	207.50	1.631	117.40	173.5	3.578	3.576	3.256	23.774	28.902	69.15	-118.10	24.25
64 - 120	64	1.15	249.10	1.957	141.10	209.40	4.298	4.297	3.919	23.793	28.985	119.60	-118.10	29.49

96mm TOP HAT FULL SECTION PROPERTIES

SECTION	Area A _g mm ²	I _x x10 ² mm ⁴	I _y x10 ² mm ⁴	Z _x ⁺ x10 ² mm ³	Z _x ⁻ x10 ² mm ³	Z _y ⁺ x10 ² mm ³	Z _y ⁻ x10 ² mm ³	r _x	r _y	J	B _x	I _w
96 - 75	206	245	152	4.80	5.44	2.99	2.99	34.5	27.1	38.7	157	63.8
96 - 100	274	325	202	6.39	7.17	3.98	3.98	34.4	27.1	91.4	158	82.8
96 - 120	328	389	242	7.65	8.53	4.77	4.77	34.4	27.1	158	158	97.3

120mm TOP HAT FULL SECTION PROPERTIES

SECTION	Mass kg/m	Area A _g mm ²	I _x x10 ² mm ⁴	Z _x ⁺ x10 ² mm ³	Z _x ⁻ x10 ² mm ³
120 - 75	1.93	246	423	6.41	7.83
120 - 100	2.58	329	563	8.53	10.40
120 - 120	3.08	393	675	10.20	12.50

LIMIT STATE CAPACITY TABLES

40mm ROOF BATTEN LIMIT STATE CAPACITY TABLE

40mm ROOF BATTEN DESIGN ASSUMPTIONS

1. All spans are equal.
2. Design Load Capacities have been calculated with roof sheets attached to the top of the battens.
3. Load required to obtain a deflection of SPAN/150.
4. Support member is assumed to be G450 steel.

40mm ROOF BATTEN TRIPLE SPAN¹ (UNLAPPED) - DESIGN CAPACITY² (kN/m)

SPAN (mm)	BATTEN SIZE						SCREW PULL OUT CAPACITY (kN/m) 2 x 12G SCREWS				SCREW PULL OUT CAPACITY (kN/m) 14 x 12G SCREWS			
	40-55			40-75			SUPPORT MEMBER THICKNESS (mm) ⁴							
	Load Inwards	Load Outwards	Deflection ³ Span/150	Load Inwards	Load Outwards	Deflection ³ Span/150	0.75	0.95	1.15	≥ 1.5	0.75	0.95	1.15	≥ 1.5
600	8.39	7.04	19.10	13.73	12.42	25.83	2.36	3.23	3.91	5.10	3.49	6.46	7.82	10.20
900	3.89	3.06	5.66	6.09	5.16	7.65	1.57	2.15	2.61	3.40	2.33	4.31	5.21	6.80
1200	2.05	1.60	2.39	3.22	2.65	3.23	1.18	1.62	1.96	2.55	1.75	3.23	3.91	5.10
1500	1.23	0.94	1.22	1.93	1.54	1.65	0.94	1.29	1.56	2.04	1.40	2.58	3.13	4.08
1800	0.80	0.59	0.71	1.26	0.95	0.96	0.79	1.08	1.30	1.70	1.16	2.15	2.61	3.40

64mm TOP HAT LIMIT STATE CAPACITY TABLES

64mm TOP HAT DESIGN ASSUMPTIONS

1. Loads are assumed to act uniformly along the top central flange of the sections or, for connections to support members, evenly between each of the lower flanges (feet).
2. Foot traffic loadings, where used, are based on AS 1562.
3. Shaded cells denote where foot traffic of 1.1 kN will exceed the serviceability requirements.
4. Capacities may be limited by fastener capacities which should be verified by the designer.

64mm 0.75BMT TOP HAT LIMIT STATE CAPACITY (kN/m)

SPAN (mm)	SINGLE				DOUBLE LAPPED				TRIPLE LAPPED			
	OUT		IN		OUT		IN		OUT		IN	
	SERVICE	STRENGTH	SERVICE	STRENGTH	SERVICE	STRENGTH	SERVICE	STRENGTH	SERVICE	STRENGTH	SERVICE	STRENGTH
1500	3.84	4.39	3.44	3.44	4.39	5.04	4.59	4.65	5.63	5.63	3.60	3.61
1750	2.77	3.15	2.87	2.87	3.42	3.73	3.37	3.95	4.23	4.14	3.02	3.10
2000	2.00	2.36	2.39	2.40	2.66	2.88	2.58	3.36	3.17	3.1	2.53	2.66
2250	1.45	1.83	1.99	2.00	2.07	2.29	2.04	2.85	2.38	2.51	2.12	2.28
2500	1.05	1.46	1.66	1.67	1.62	1.86	1.65	2.43	1.78	2.03	1.77	1.95
2750	0.76	1.19	1.38	1.40	1.26	1.55	1.37	2.06	1.34	1.68	1.48	1.67
3000	0.55	0.99	1.15	1.17	0.98	1.31	1.15	1.75	1.00	1.41	1.24	1.44
3250	0.39	0.83	0.96	0.97	0.76	1.12	0.98	1.49	0.75	1.21	1.04	1.23
3500	0.29	0.71	0.80	0.81	0.59	0.97	0.84	1.27	0.56	1.04	0.87	1.06
3750	0.21	0.61	0.67	0.68	0.46	0.85	0.73	1.08	0.42	0.91	0.73	0.91
4000	0.15	0.53	0.55	0.57	0.36	0.75	0.65	0.91	0.32	0.80	0.61	0.78
4250					0.28	0.66	0.57	0.78	0.24	0.71	0.51	0.67
4500					0.22	0.59	0.51	0.66	0.18	0.63	0.43	0.57
4750					0.17	0.53	0.46	0.56	0.13	0.57	0.36	0.49
5000											0.30	0.42
5250											0.25	0.36
5500											0.21	0.31
5750											0.18	0.26
6000											0.15	0.23

64mm 0.95BMT TOP HAT LIMIT STATE CAPACITY (kN/m)

SPAN (mm)	SINGLE				DOUBLE LAPPED				TRIPLE LAPPED			
	OUT		IN		OUT		IN		OUT		IN	
	SERVICE	STRENGTH	SERVICE	STRENGTH	SERVICE	STRENGTH	SERVICE	STRENGTH	SERVICE	STRENGTH	SERVICE	STRENGTH
1500	5.21	5.65	5.66	5.80	6.42	6.87	6.92	7.67	7.22	7.22	7.16	7.16
1750	3.82	4.11	4.18	4.31	5.13	5.11	5.08	5.53	5.55	5.80	5.86	5.31
2000	2.44	3.12	3.21	3.33	4.09	3.95	3.88	4.17	4.27	4.49	4.80	4.10
2250	1.64	2.45	2.55	2.65	3.27	3.15	3.06	3.25	3.28	3.58	3.93	3.26
2500	1.15	1.97	2.07	2.16	2.61	2.557	2.48	2.60	2.34	2.92	3.22	2.66
2750	0.83	1.62	1.72	1.80	2.08	2.14	2.04	2.13	1.79	2.43	2.63	2.21
3000	0.62	1.35	1.45	1.52	1.66	1.81	1.72	1.77	1.37	2.06	2.16	1.87
3250	0.48	1.15	1.24	1.30	1.33	1.55	1.46	1.49	1.04	1.76	1.77	1.60
3500	0.37	0.98	1.07	1.13	1.06	1.34	1.26	1.28	0.80	1.53	1.45	1.38
3750	0.29	0.85	0.93	0.99	0.85	1.18	1.10	1.10	0.61	1.34	1.18	1.21
4000	0.24	0.75	0.82	0.87	0.68	1.04	0.96	0.96	0.46	1.18	0.97	1.07
4250	0.19	0.66	0.73	0.78	0.54	0.92	0.85	0.85	0.35	1.05	0.79	0.95
4500	0.16	0.59	0.65	0.69	0.43	0.83	0.76	0.75	0.27	0.94	0.65	0.85
4750					0.34	0.75	0.68	0.67	0.21	0.85	0.53	0.77
5000					0.28	0.68	0.61	0.60	0.16	0.77	0.44	0.69
5250					0.22	0.62	0.56	0.54	0.12	0.70	0.36	0.63
5500					0.18	0.56	0.51	0.49	0.09	0.64	0.29	0.58
5750											0.24	0.53
6000											0.20	0.49

64mm 1.15BMT TOP HAT LIMIT STATE CAPACITY (kN/m)

SPAN (mm)	SINGLE				DOUBLE LAPPED				TRIPLE LAPPED			
	OUT		IN		OUT		IN		OUT		IN	
	SERVICE	STRENGTH	SERVICE	STRENGTH	SERVICE	STRENGTH	SERVICE	STRENGTH	SERVICE	STRENGTH	SERVICE	STRENGTH
1500	7.29	7.33	7.56	7.58	6.47	6.47	8.73	9.55	7.40	7.40	9.65	9.65
1750	4.60	5.27	5.55	5.59	5.20	5.86	6.71	6.92	6.35	6.47	8.15	8.18
2000	2.92	4.03	4.25	4.29	4.18	4.61	5.05	5.24	5.54	5.66	6.29	6.30
2250	1.96	3.18	3.36	3.40	3.37	3.73	3.93	4.10	4.12	4.91	4.99	5.01
2500	1.37	2.58	2.72	2.76	2.71	3.08	3.14	3.29	2.87	4.18	4.05	4.08
2750	0.99	2.13	2.25	2.29	2.18	2.60	2.56	2.70	2.07	3.30	3.28	3.38
3000	0.74	1.79	1.89	1.93	1.75	2.22	2.13	2.25	1.54	2.85	2.66	2.86
3250	0.56	1.52	1.61	1.65	1.41	1.92	1.79	1.90	1.17	2.46	2.16	2.44
3500	0.44	1.31	1.39	1.42	1.13	1.68	1.53	1.63	0.91	2.13	1.75	2.11
3750	0.34	1.14	1.21	1.24	0.91	1.49	1.32	1.41	0.72	1.84	1.42	1.85
4000	0.28	1.00	1.06	1.09	0.73	1.32	1.15	1.24	0.58	1.59	1.15	1.63
4250	0.22	0.89	0.94	0.97	0.59	1.19	1.01	1.09	0.47	1.37	0.93	1.42
4500	0.18	0.79	0.84	0.87	0.48	1.07	0.90	0.97	0.38	1.18	0.75	1.29
4750					0.38	0.97	0.80	0.86	0.32	1.02	0.61	1.16
5000					0.31	0.89	0.72	0.78	0.27	0.88	0.50	1.05
5250					0.25	0.81	0.64	0.70	0.23	0.76	0.40	0.96
5500					0.20	0.75	0.58	0.64	0.19	0.66	0.33	0.87
5750					0.16	0.69	0.53	0.58	0.17	0.57	0.26	0.80
6000											0.21	0.74

96mm TOP HAT LIMIT STATE CAPACITY TABLES

96mm TOP HAT DESIGN ASSUMPTIONS

1. Loads are assumed to act uniformly along the top central flange of the sections.
2. Foot traffic loadings, where applicable, are based on AS 1562.
3. Support member is assumed to be high tensile steel.
4. For full compliance to AS 4600 the serviceability limit must be regarded as the strength limit state design capacity.
5. Fastener capacity can be increased by 18% if 2 x No.14 screws are used, increased by 30% if 4 x No.12 screws are used, or increased by 40% if 4 x No.14 screws are used.



96mm TOP HAT SINGLE SPAN - OUTWARDS DESIGN CAPACITY (kN/m)

SPAN (mm)	MEMBER DESIGN CAPACITY FOR SECTION SHOWN						2 x No.12 FASTENER CAPACITY					
	0.75		1.00		1.20		SUPPORT MEMBER THICKNESS (mm)					
	svblty	strength	svblty	strength	svblty	strength	1.0	1.2	1.5	1.9	2.4	3.0
1500	5.18	6.01	7.70	10.75	9.81	13.28	3.39	3.84	4.43	5.61	7.09	8.86
1750	3.80	4.41	5.65	7.90	7.21	7.90	2.90	3.29	3.80	4.81	6.08	7.60
2000	2.91	3.37	4.03	5.47	4.89	6.76	2.54	2.88	3.32	4.21	5.32	6.65
2250	2.12	2.67	2.83	3.76	3.43	4.57	2.26	2.56	2.9	3.74	4.73	5.91
2500	1.55	1.89	2.06	2.77	2.50	3.53	2.03	2.30	2.66	3.37	4.25	5.32
2750	1.16	1.54	1.55	2.29	1.88	2.92	1.85	2.09	2.42	3.06	3.87	4.83
3000	0.90	1.29	1.19	1.92	1.45	2.45	1.69	1.92	2.21	2.81	3.54	4.43
3250	0.70	1.10	0.94	1.64	1.14	2.09	1.56	1.77	2.04	2.59	3.27	4.09
3500	0.56	0.95	0.75	1.41	0.91	1.80	1.45	1.65	1.90	2.41	3.04	3.80
3750	0.53	0.83	0.59	1.23	0.73	1.57	1.35	1.54	1.77	2.25	2.84	3.55
4000	0.34	0.73	0.47	1.08	0.58	1.38	1.27	1.44	1.66	2.10	2.66	3.32
4250	0.27	0.65	0.37	0.96	0.46	1.22	1.20	1.36	1.56	1.98	2.50	3.13
4500	0.22	0.58	0.30	0.86	0.38	1.09	1.13	1.28	1.48	1.87	2.36	2.95
4750			0.25	0.77	0.31	0.98	1.07	1.21	1.40	1.77	2.24	2.80
5000			0.21	0.69	0.27	0.88	1.02	1.15	1.33	1.68	2.13	2.66
5250					0.22	0.80	0.97	1.10	1.27	1.60	2.03	2.53

96mm TOP HAT SINGLE SPAN - INWARDS DESIGN CAPACITY (kN/m)

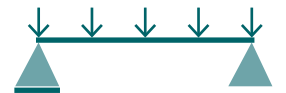

SPAN (mm)	MEMBER DESIGN CAPACITY FOR SECTION SHOWN								
	0.75			1.00			1.20		
	L/90	svblty	strength	L/90	svblty	strength	L/90	svblty	strength
1500	10.11	3.16	3.16	15.92	5.32	5.32	19.52	7.36	7.36
1750	6.37	2.71	2.54	10.03	4.56	4.47	12.29	6.31	6.22
2000	4.27	2.37	1.94	6.72	3.99	3.42	8.23	4.94	4.77
2250	3.00	1.80	1.53	4.72	2.83	2.71	5.38	3.74	3.76
2500	2.18	1.31	1.25	3.44	2.06	2.20	4.22	2.53	3.08
2750	1.64	0.98	1.03	2.59	1.55	1.82	3.17	1.90	2.52
3000	1.26	0.76	0.86	1.99	1.19	1.53	2.44	1.46	2.12
3250	0.99	0.60	0.74	1.57	0.94	1.30	1.92	1.15	1.80
3500	0.80	0.48	0.64	1.25	0.75	1.07	1.52	0.92	1.55
3750	0.65	0.39	0.56	1.02	0.61	0.93	1.25	0.75	1.36
4000	0.53	0.32	0.48	0.84	0.50	0.82	1.03	0.62	1.19
4250	0.44	0.27	0.43	0.70	0.42	0.73	0.86	0.51	1.06
4500	0.37	0.22	0.38	0.59	0.35	0.65	0.72	0.43	0.94
4750				0.50	0.30	0.58	0.61	0.37	0.85
5000				0.43	0.26	0.52	0.53	0.32	0.77
5250							0.46	0.27	0.69

96mm TOP HAT DOUBLE LAPPED - OUTWARDS DESIGN CAPACITY (kN/m)

SPAN (mm)	MEMBER DESIGN CAPACITY FOR SECTION SHOWN						2 x No.12 FASTENER CAPACITY					
	0.75		1.00		1.20		SUPPORT MEMBER THICKNESS (mm)					
	svblty	strength	svblty	strength	svblty	strength	1.0	1.2	1.5	1.9	2.4	3.0
1500	6.05	6.04	6.44	6.44	6.44	6.44	1.15	1.31	1.83	2.25	2.61	3.23
1750	4.51	4.74	4.83	5.52	5.52	5.52	0.99	1.12	1.57	1.93	2.23	2.79
2000	3.02	3.81	4.03	4.83	4.83	4.83	0.86	0.98	1.37	1.69	1.96	2.44
2250	2.12	3.11	2.83	4.29	3.43	4.29	0.77	0.87	1.22	1.50	1.74	2.17
2500	1.55	2.52	2.06	3.86	2.50	3.86	0.69	0.78	1.10	1.35	1.56	1.96
2750	1.16	2.08	1.55	3.43	1.88	3.51	0.63	0.71	1.00	1.23	1.42	1.78
3000	0.90	1.75	1.19	2.88	1.45	3.22	0.58	0.65	0.92	1.12	1.30	1.63
3250	0.70	1.49	0.94	2.45	1.14	2.94	0.53	0.60	0.85	1.04	1.20	1.50
3500	0.56	1.29	0.75	2.12	0.91	2.53	0.49	0.56	0.78	0.96	1.12	1.40
3750	0.46	1.12	0.61	1.84	0.74	2.20	0.46	0.52	0.73	0.90	1.04	1.30
4000	0.38	0.98	0.50	1.62	0.61	1.94	0.43	0.49	0.69	0.84	0.98	1.22
4250	0.31	0.87	0.42	1.43	0.51	1.72	0.41	0.46	0.65	0.79	0.92	1.15
4500	0.27	0.78	0.35	1.28	0.43	1.53	0.38	0.44	0.61	0.75	0.87	1.09
4750	0.23	0.70	0.30	1.15	0.36	1.38	0.36	0.41	0.58	0.71	0.82	1.03
5000	0.19	0.63	0.26	1.04	0.31	1.24	0.35	0.39	0.55	0.68	0.78	0.98
5250	0.17	0.57	0.22	0.94	0.27	1.13	0.33	0.37	0.52	0.64	0.75	0.93
5500	0.15	0.52	0.19	0.86	0.24	1.03	0.31	0.36	0.50	0.60	0.71	0.89
5750	0.13	0.48	0.17	0.78	0.21	0.94	0.30	0.34	0.48	0.59	0.68	0.85
6000			0.15	0.72	0.18	0.86	0.29	0.33	0.46	0.56	0.65	0.82

96mm TOP HAT DOUBLE LAPPED - INWARDS DESIGN CAPACITY (kN/m)

SPAN (mm)	MEMBER DESIGN CAPACITY FOR SECTION SHOWN								
	0.75			1.00			1.20		
	L/90	svblty	strength	L/90	svblty	strength	L/90	svblty	strength
1500	19.09	3.95	3.16	30.00	6.62	5.30	36.30	8.66	6.93
1750	12.02	3.39	2.53	18.90	5.40	4.32	22.80	7.03	5.62
2000	8.05	2.95	1.94	12.68	4.51	3.44	15.30	5.85	4.68
2250	5.65	2.52	1.53	8.91	3.83	2.72	10.70	4.95	3.78
2500	4.12	2.18	1.24	6.49	3.30	2.20	7.84	4.25	3.06
2750	3.10	1.86	1.03	4.88	2.86	1.82	5.91	3.59	2.53
3000	2.39	1.43	0.86	3.76	2.25	1.53	4.59	2.76	2.12
3250	1.88	1.13	0.73	2.96	1.77	1.30	3.62	2.17	1.81
3500	1.50	0.90	0.63	2.37	1.42	1.12	2.90	1.74	1.56
3750	1.22	0.73	0.55	1.92	1.15	0.98	2.36	1.41	1.36
4000	1.01	0.60	0.49	1.59	0.95	0.86	1.94	1.17	1.20
4250	0.84	0.10	0.43	1.32	0.79	0.76	1.62	0.97	1.06
4500	0.71	0.42	0.38	1.11	0.67	0.68	1.36	0.82	0.94
4750	0.60	0.36	0.34	0.95	0.57	0.61	1.16	0.70	0.85
5000	0.52	0.31	0.31	0.81	0.49	0.55	0.99	0.60	0.76
5250	0.45	0.27	0.28	0.70	0.42	0.50	0.86	0.52	0.69
5500	0.39	0.23	0.26	0.61	0.37	0.16	0.75	0.45	0.63
5750	-	-	-	0.53	0.32	0.42	0.65	0.39	0.58
6000	-	-	-	0.47	0.28	0.38	0.58	0.35	0.53

96mm TOP HAT DOUBLE UNLAPPED - OUTWARDS DESIGN CAPACITY (kN/m)

SPAN (mm)	MEMBER DESIGN CAPACITY FOR SECTION SHOWN						2 x No.12 FASTENER CAPACITY						
	0.75		1.00		1.20		SUPPORT MEMBER THICKNESS (mm)						
	svbly	strength	svbly	strength	svbly	strength	1.0	1.2	1.5	1.9	2.4	3.0	
1500	4.64	4.64	6.19	6.19	6.53	6.53	1.17	1.33	1.87	2.29	2.66	3.32	
1750	3.98	3.98	5.31	5.31	5.60	5.60	1.01	1.14	1.60	1.97	2.28	2.85	
2000	3.02	3.26	4.03	4.64	4.89	4.90	0.88	1.00	1.40	1.72	1.99	2.49	
2250	2.12	2.65	2.83	4.13	3.43	4.35	0.78	0.89	1.24	1.53	1.77	2.22	
2500	1.55	2.16	2.06	3.71	2.50	3.92	0.70	0.80	1.12	1.38	1.60	1.99	
2750	1.16	1.79	1.55	3.19	1.88	3.56	0.64	0.73	1.02	1.25	1.45	1.81	
3000	0.90	1.50	1.19	2.68	1.45	3.26	0.59	0.67	0.93	1.15	1.33	1.66	
3250	0.70	1.28	0.94	2.29	1.14	2.83	0.54	0.62	0.86	1.06	1.23	1.53	
3500	0.56	1.10	0.75	1.97	0.91	2.44	0.50	0.58	0.80	0.98	1.14	1.42	
3750	0.46	0.96	0.61	1.72	0.74	2.12	0.47	0.53	0.75	0.92	1.06	1.33	
4000	0.38	0.84	0.50	1.51	0.61	1.87	0.44	0.50	0.70	0.86	1.00	1.25	
4250	0.31	0.75	0.42	1.34	0.51	1.65	0.41	0.47	0.66	0.81	0.94	0.117	
4500	0.27	0.67	0.35	1.19	0.43	1.48	0.39	0.44	0.62	0.76	0.89	1.11	
4750	0.23	0.60	0.30	1.07	0.36	1.32	0.37	0.42	0.59	0.72	0.84	1.05	
5000	0.19	0.54	0.26	0.97	0.31	1.19	0.35	0.40	0.56	0.69	0.80	1.00	
5250	0.17	0.49	0.22	0.89	0.27	1.08	0.34	0.38	0.53	0.66	0.76	0.95	
5500			0.19	0.80	0.24	0.99	0.32	0.36	0.51	0.63	0.73	0.91	
5750			0.17	0.74	0.21	0.90	0.31	0.35	0.49	0.60	0.69	0.87	
6000			0.15	0.67	0.18	0.83	0.29	0.33	0.47	0.57	0.67	0.83	

96mm TOP HAT DOUBLE UNLAPPED - INWARDS DESIGN CAPACITY (kN/m)

SPAN (mm)	MEMBER DESIGN CAPACITY FOR SECTION SHOWN								
	0.75			1.00			1.20		
	L/90	svbly	strength	L/90	svbly	strength	L/90	svbly	strength
1500	10.11	4.31	3.52	15.93	7.26	6.12	19.52	10.00	8.50
1750	6.37	3.70	2.59	10.03	6.02	4.49	12.29	7.38	6.24
2000	4.27	2.56	1.98	6.72	4.03	3.44	8.23	4.94	4.78
2250	3.00	1.80	1.56	4.72	2.83	2.72	5.78	3.47	3.78
2500	2.18	1.31	1.27	3.44	2.06	2.20	4.22	2.53	3.06
2750	1.64	0.98	1.05	2.59	1.55	1.82	3.17	1.90	2.53
3000	1.26	0.76	0.88	1.99	1.19	1.53	2.44	1.46	2.12
3250	0.99	0.60	0.75	1.57	0.94	1.30	1.92	1.15	1.81
3500	0.80	0.48	0.65	1.25	0.75	1.12	1.54	0.92	1.56
3750	0.65	0.39	0.56	1.02	0.61	0.98	1.25	0.75	1.36
4000	0.53	0.32	0.50	0.84	0.50	0.86	1.03	0.62	1.20
4250	0.44	0.27	0.44	0.70	0.42	0.76	0.86	0.51	1.06
4500	0.37	0.22	0.39	0.59	0.35	0.68	0.72	0.43	0.94
4750	0.32	0.19	0.35	0.50	0.30	0.61	0.61	0.37	0.85
5000	0.27	0.16	0.32	0.43	0.26	0.55	0.53	0.32	0.76
5250	0.24	0.14	0.29	0.37	0.22	0.50	0.46	0.27	0.69
5500	0.21	0.12	0.26	0.32	0.19	0.45	0.40	0.24	0.63
5750	0.18	0.11	0.24	0.28	0.17	0.42	0.35	0.21	0.58
6000	0.16	0.09	0.22	0.25	0.15	0.38	0.30	0.18	0.53

96mm TOP HAT DESIGN ASSUMPTIONS

1. Loads are assumed to act uniformly along the top central flange of the sections.
2. Foot traffic loadings, where applicable, are based on AS 1562.
3. Support member is assumed to be high tensile steel.
4. For full compliance to AS 4600 the serviceability limit must be regarded as the strength limit state design capacity.
5. Fastener capacity can be increased by 18% if 2 x No.14 screws are used, increased by 30% if 4 x No.12 screws are used, or increased by 40% if 4 x No.14 screws are used.
6. Double span beams are supported and attached at each end and in the middle (unlapped) or have a structural lap (15%) at that central support (lapped). Each span is assumed to be equal.
7. Triple span beams are supported and attached at two equally spaced intermediate supports (unlapped) or have a structural lap (15%) at those intermediate supports (lapped).

96mm TOP HAT TRIPLE LAPPED - OUTWARDS DESIGN CAPACITY (kN/m)

SPAN (mm)	MEMBER DESIGN CAPACITY FOR SECTION SHOWN						2 x No.12 FASTENER CAPACITY						
	0.75		1.00		1.20		SUPPORT MEMBER THICKNESS (mm)						
	svblty	strength	svblty	strength	svblty	strength	1.0	1.2	1.5	1.9	2.4	3.0	
1500	7.17	7.17	7.38	7.38	7.38	7.38	1.32	1.51	2.11	2.59	3.00	3.75	
1750	5.73	5.73	6.33	6.33	6.33	6.33	1.14	1.29	1.81	2.22	2.57	3.21	
2000	4.76	4.76	5.54	5.54	5.54	5.54	0.99	1.13	1.58	1.94	2.25	2.81	
2250	3.69	3.69	4.92	4.92	4.92	4.92	0.88	1.00	1.40	1.73	2.00	2.50	
2500	2.92	2.92	3.90	3.90	4.43	4.43	0.79	0.90	1.26	1.55	1.80	2.25	
2750	2.19	2.19	2.93	2.94	3.55	3.55	0.72	0.82	1.15	1.41	1.64	2.05	
3000	1.69	1.69	2.25	2.47	2.73	2.95	0.66	0.75	1.05	1.29	1.50	1.88	
3250	1.33	1.42	1.77	2.10	2.15	2.69	0.61	0.69	0.97	1.19	1.39	1.73	
3500	1.06	1.22	1.42	1.82	1.72	2.31	0.57	0.65	0.90	1.11	1.29	1.61	
3750	0.86	1.06	1.15	1.58	1.40	2.02	0.53	0.60	0.84	1.04	1.20	1.50	
4000	0.71	0.94	0.95	1.39	1.15	1.78	0.50	0.56	0.79	0.97	1.13	1.41	
4250	0.56	0.83	0.76	1.23	0.94	1.57	0.47	0.53	0.74	0.91	1.06	1.32	
4500	0.45	0.74	0.62	1.10	0.77	1.40	0.44	0.50	0.70	0.86	1.00	1.25	
4750	0.37	0.66	0.51	0.98	0.63	1.26	0.42	0.48	0.67	0.82	0.95	1.18	
5000	0.30	0.60	0.42	0.89	0.53	1.14	0.40	0.45	0.63	0.78	0.90	1.13	
5250	0.25	0.54	0.35	0.81	0.44	1.03	0.38	0.43	0.60	0.74	0.86	1.07	
5500	0.21	0.50	0.30	0.74	0.37	0.94	0.36	0.41	0.57	0.71	0.82	1.02	
5750			0.25	0.67	0.32	0.86	0.35	0.39	0.55	0.68	0.78	0.98	
6000			0.22	0.62	0.27	0.78	0.33	0.38	0.53	0.65	0.75	0.94	

96mm TOP HAT TRIPLE LAPPED - INWARDS DESIGN CAPACITY (kN/m)

SPAN (mm)	MEMBER DESIGN CAPACITY FOR SECTION SHOWN								
	0.75			1.00			1.20		
	L/90	svblty	strength	L/90	svblty	strength	L/90	svblty	strength
1500	19.09	4.01	3.21	30.06	6.74	5.39	36.83	9.32	7.46
1750	12.02	3.43	2.56	18.93	5.78	4.47	23.20	7.99	6.24
2000	8.05	3.00	1.96	12.68	5.05	3.42	15.54	6.99	4.78
2250	5.65	2.67	1.55	8.91	4.49	2.70	10.91	6.22	3.78
2500	4.12	2.40	1.25	6.49	3.90	2.19	7.96	4.77	3.06
2750	3.10	1.86	1.04	4.88	2.93	1.81	5.98	3.59	2.53
3000	2.39	1.43	0.87	3.76	2.25	1.52	4.60	2.76	2.12
3250	1.88	1.13	0.74	2.96	1.77	1.30	3.62	2.17	1.81
3500	1.50	0.90	0.64	2.37	1.42	1.12	2.90	1.74	1.56
3750	1.22	0.73	0.56	1.92	1.15	0.97	2.36	1.41	1.36
4000	1.01	0.60	0.49	1.59	0.95	0.86	1.94	1.17	1.20
4250	0.84	0.50	0.43	1.32	0.79	0.76	1.62	0.97	1.06
4500	0.71	0.42	0.39	1.11	0.67	0.68	1.36	0.82	0.94
4750	0.60	0.36	0.35	0.95	0.57	0.61	1.16	0.70	0.85
5000	0.52	0.31	0.31	0.81	0.49	0.55	0.99	0.60	0.76
5250	0.45	0.27	0.28	0.70	0.42	0.50	0.86	0.52	0.69
5500	0.39	0.23	0.26	0.61	0.37	0.45	0.75	0.45	0.63
5750				0.53	0.32	0.41	0.65	0.39	0.58
6000				0.47	0.28	0.38	0.58	0.35	0.53

96mm TOP HAT TRIPLE UNLAPPED - OUTWARDS DESIGN CAPACITY (kN/m)

SPAN (mm)	MEMBER DESIGN CAPACITY FOR SECTION SHOWN						2 x No.12 FASTENER CAPACITY					
	0.75		1.00		1.20		SUPPORT MEMBER THICKNESS (mm)					
	svblty	strength	svblty	strength	svblty	strength	1.0	1.2	1.5	1.9	2.4	3.0
1500	5.28	5.28	7.03	7.03	7.42	7.42	1.33	1.52	2.12	2.61	3.02	3.78
1750	4.52	4.52	6.03	6.03	6.36	6.36	1.14	1.30	1.82	2.23	2.59	3.24
2000	3.85	3.85	5.28	5.28	5.56	5.56	1.00	1.14	1.59	1.96	2.27	2.83
2250	3.16	3.16	4.69	4.69	4.95	4.95	0.89	1.01	1.41	1.74	2.01	2.52
2500	2.64	2.64	3.90	3.90	4.45	4.45	0.80	0.91	1.27	1.56	1.81	2.27
2750	2.19	2.19	2.93	2.93	3.55	3.55	0.73	0.83	1.16	1.43	1.65	2.06
3000	1.69	1.69	2.25	2.41	2.73	2.97	0.67	0.76	1.06	1.30	1.51	1.89
3250	1.33	1.28	1.77	2.05	2.15	2.61	0.62	0.70	0.98	1.20	1.39	1.74
3500	1.06	1.10	1.42	1.77	1.72	2.25	0.57	0.65	0.91	1.12	1.30	1.62
3750	0.85	0.96	1.12	1.54	1.38	1.96	0.53	0.61	0.85	1.04	1.21	1.51
4000	0.67	0.85	0.89	1.35	1.09	1.73	0.50	0.57	0.80	0.98	1.13	1.42
4250	0.53	0.75	0.71	1.20	0.88	1.53	0.47	0.54	0.75	0.92	1.07	1.33
4500	0.43	0.67	0.58	1.07	0.72	1.36	0.44	0.51	0.71	0.87	1.01	1.26
4750	0.35	0.60	0.48	0.96	0.59	1.22	0.42	0.48	0.67	0.82	0.95	1.19
5000	0.29	0.54	0.39	0.86	0.49	1.10	0.40	0.46	0.64	0.78	0.91	1.13
5250	0.24	0.49	0.33	0.78	0.41	1.00	0.38	0.43	0.61	0.75	0.86	1.08
5500	0.20	0.45	0.28	0.71	0.35	0.91	0.36	0.41	0.58	0.71	0.82	1.03
5750			0.24	0.66	0.30	0.83	0.35	0.40	0.55	0.68	0.79	0.99
6000			0.20	0.60	0.26	0.77	0.33	0.38	0.53	0.65	0.76	0.94

96mm TOP HAT TRIPLE UNLAPPED- INWARDS DESIGN CAPACITY (kN/m)

SPAN (mm)	MEMBER DESIGN CAPACITY FOR SECTION SHOWN								
	0.75			1.00			1.20		
	L/90	svblty	strength	L/90	svblty	strength	L/90	svblty	strength
1500	19.09	3.95	3.16	30.00	6.62	5.30	36.30	8.66	6.93
1750	12.02	3.39	2.53	18.90	5.40	4.32	22.80	7.03	5.62
2000	8.05	2.95	1.94	12.68	4.51	3.44	15.30	5.85	4.68
2250	5.65	2.52	1.53	8.91	3.83	2.72	10.70	4.95	3.78
2500	4.12	2.18	1.24	6.49	3.30	2.20	7.84	4.25	3.06
2750	3.10	1.86	1.03	4.88	2.86	1.82	5.91	3.59	2.53
3000	2.39	1.43	0.86	3.76	2.25	1.53	4.59	2.76	2.12
3250	1.88	1.13	0.73	2.96	1.77	1.30	3.62	2.17	1.81
3500	1.50	0.90	0.63	2.37	1.42	1.12	2.90	1.74	1.56
3750	1.22	0.73	0.55	1.92	1.15	0.98	2.36	1.41	1.36
4000	1.01	0.60	0.49	1.59	0.95	0.86	1.94	1.17	1.20
4250	0.84	0.10	0.43	1.32	0.79	0.76	1.62	0.97	1.06
4500	0.71	0.42	0.38	1.11	0.67	0.68	1.36	0.82	0.94
4750	0.60	0.36	0.34	0.95	0.57	0.61	1.16	0.70	0.85
5000	0.52	0.31	0.31	0.81	0.49	0.55	0.99	0.60	0.76
5250	0.45	0.27	0.28	0.70	0.42	0.50	0.86	0.52	0.69
5500	0.39	0.23	0.26	0.61	0.37	0.16	0.75	0.45	0.63
5750				0.53	0.32	0.42	0.65	0.39	0.58
6000				0.47	0.28	0.38	0.58	0.35	0.53

120mm TOP HAT LIMIT STATE CAPACITY TABLES

120mm TOP HAT DESIGN ASSUMPTIONS

1. Support member is assumed to be G450 steel.
2. Outward Capacities may be limited by fastener capacity - refer Screw Pull Out capacity columns.
3. Loads are assumed to act uniformly along the top central flange of the sections or, for connections to support members, evenly between each of the lower flanges (feet).
4. Foot traffic loadings, where used, are based on AS 1562.

120mm TOP HAT SINGLE SPAN - OUTWARDS DESIGN CAPACITY (kN/m)

SPAN (mm)	MEMBER DESIGN CAPACITY FOR SECTION SHOWN			SCREW PULL OUT CAPACITY 2 x No.14 ²				2/ M12 BOLTS
	0.75	1.00	1.20	SUPPORT MEMBER ¹ THICKNESS (mm)				
	strength	strength	strength	0.75	0.95	1.15	≥ 1.5	
2000	4.48	5.78	6.93	3.08	4.58	5.54	7.02	7.88
2250	3.44	4.34	5.20	2.74	4.04	4.93	6.24	7.00
2500	2.67	3.38	4.05	2.46	3.66	4.43	5.61	6.30
2750	2.14	2.67	3.20	2.24	3.33	4.03	5.10	5.73
3000	1.75	2.21	2.64	2.05	3.05	3.69	4.68	5.25
3250	1.46	1.82	2.18	1.90	2.82	3.41	4.32	4.85
3500	1.24	1.55	1.86	1.76	2.62	3.17	4.01	4.50
3750	1.06	1.32	1.58	1.64	2.44	2.96	3.74	4.20
4000	0.93	1.14	1.37	1.54	2.29	2.77	3.51	3.94
4250	0.80	1.00	1.19	1.45	2.15	2.61	3.30	3.71
4500	0.71	0.88	1.06	1.37	2.04	2.46	3.12	3.50
4750	0.63	0.78	0.94	1.30	1.93	2.33	2.95	3.32
5000	0.57	0.70	0.84	1.23	1.83	2.22	2.81	3.15
5250	0.51	0.63	0.75	1.17	1.74	2.11	2.67	3.00
5500	0.46	0.57	0.68	1.12	1.67	2.02	2.55	2.86
5750	0.42	0.52	0.63	1.07	1.59	1.93	2.44	2.74
6000	0.38	0.47	0.57	1.03	1.53	1.85	2.34	2.63

120mm TOP HAT SINGLE SPAN - INWARDS DESIGN CAPACITY (kN/m)

SPAN (mm)	MEMBER DESIGN CAPACITY FOR SECTION SHOWN					
	0.75		1.00		1.20	
	L/100	strength	L/100	strength	L/100	strength
2000	8.12	3.67	10.81	4.74	12.96	5.65
2250	5.70	2.81	7.59	3.56	9.10	4.24
2500	4.16	2.19	5.53	2.77	6.64	3.30
2750	3.12	1.75	4.16	2.19	4.99	2.61
3000	2.41	1.43	3.20	1.81	3.84	2.16
3250	1.89	1.20	2.52	1.49	3.02	1.78
3500	1.52	1.01	2.02	1.27	2.42	1.51
3750	1.23	0.87	1.64	1.08	1.97	1.29
4000	1.02	0.76	1.35	0.94	1.62	1.12
4250	0.85	0.66	1.13	0.82	1.35	0.97
4500	0.71	0.58	0.95	0.72	1.14	0.86
4750	0.61	0.52	0.81	0.64	0.97	0.77
5000	0.52	0.46	0.69	0.57	0.83	0.68
5250	0.45	0.42	0.60	0.52	0.72	0.62
5500	0.39	0.37	0.52	0.47	0.62	0.56
5750	0.34	0.34	0.45	0.43	0.55	0.51
6000	0.30	0.31	0.40	0.39	0.48	0.46

NOTE: Deflection limits can be used for both outward and inward loads.

120mm TOP HAT DOUBLE SPAN LAPPED - OUTWARDS DESIGN CAPACITY (kN/m)

SPAN (mm)	MEMBER DESIGN CAPACITY FOR SECTION SHOWN			SCREW PULL OUT CAPACITY 4 x No.14 ²				2/M12 BOLTS
	0.75	1.00	1.20	SUPPORT MEMBER' THICKNESS (mm)				
	strength	strength	strength	0.75	0.95	1.15	≥ 1.5	
2000	4.18	5.95	7.13	3.08	4.58	5.54	7.02	7.88
2250	3.70	5.24	6.28	2.74	4.07	4.93	6.24	7.00
2500	3.34	4.61	5.52	2.46	3.66	4.43	5.61	6.30
2750	3.02	4.03	4.83	2.24	3.33	4.03	5.10	5.73
3000	2.53	3.48	4.47	2.05	3.05	3.69	4.68	5.25
3250	2.07	3.06	3.67	1.90	2.82	3.41	4.32	4.85
3500	1.67	2.70	3.24	1.76	2.62	3.17	4.01	4.50
3750	1.40	2.36	2.83	1.64	2.44	2.96	3.74	4.20
4000	1.15	2.08	2.49	1.54	2.29	2.77	3.51	3.94
4250	0.98	1.85	2.22	1.45	2.15	2.61	3.30	3.71
4500	0.93	1.65	1.98	1.37	2.04	2.46	3.12	3.50
4750	0.87	1.48	1.77	1.30	1.93	2.33	2.95	3.32
5000	0.84	1.33	1.60	1.23	1.83	2.22	2.81	3.15
5250	0.80	1.20	1.44	1.17	1.74	2.11	2.67	3.00
5500	0.76	1.10	1.32	1.12	1.67	2.02	2.55	2.86
5750	0.72	0.99	1.19	1.07	1.59	1.93	2.44	2.74
6000	0.66	0.91	1.09	1.03	1.53	1.85	2.34	2.63

120mm TOP HAT DOUBLE SPAN LAPPED - INWARDS DESIGN CAPACITY (kN/m)

SPAN (mm)	MEMBER DESIGN CAPACITY FOR SECTION SHOWN					
	0.75		1.00		1.20	
	L/100	strength	L/100	strength	L/100	strength
2000	10.20	3.43	13.50	4.56	16.20	5.85
2250	7.13	3.04	9.49	4.02	11.40	5.15
2500	5.20	2.74	6.92	3.53	8.29	4.53
2750	3.91	2.48	5.20	3.09	6.23	3.96
3000	3.01	2.08	4.00	2.67	4.80	3.42
3250	2.37	1.70	3.15	2.34	3.78	3.01
3500	1.89	1.39	2.52	2.07	3.02	2.66
3750	1.54	1.15	2.05	1.81	2.46	2.32
4000	1.27	0.94	1.69	1.59	2.03	2.04
4250	1.06	0.80	1.41	1.42	1.69	1.82
4500	0.89	0.76	1.19	1.27	1.42	1.63
4750	0.76	0.72	1.01	1.13	1.21	1.45
5000	0.65	0.69	0.86	1.02	1.04	1.31
5250	0.56	0.65	0.75	0.92	0.90	1.18
5500	0.49	0.62	0.65	0.84	0.78	1.08
5750	0.43	0.59	0.57	0.76	0.68	0.98
6000	0.38	0.54	0.50	0.70	0.60	0.89

NOTE: Deflection limits can be used for both outward and inward loads.

120mm TOP HAT DOUBLE SPAN UNLAPPED - OUTWARDS DESIGN CAPACITY (kN/m)

SPAN (mm)	MEMBER DESIGN CAPACITY FOR SECTION SHOWN			SCREW PULL OUT CAPACITY 4 × No.14 ²				2/M12 BOLTS
	0.75	1.00	1.20	SUPPORT MEMBER1 THICKNESS (mm)				
	strength	strength	strength	0.75	0.95	1.15	≥ 1.5	
2000	3.43	4.88	5.85	3.08	4.58	5.54	7.02	7.88
2250	3.04	4.30	5.15	2.74	4.07	4.93	6.24	7.00
2500	2.74	3.78	4.52	2.46	3.66	4.43	5.61	6.30
2750	2.48	3.30	3.96	2.24	3.33	4.03	5.10	5.73
3000	2.08	2.86	3.42	2.05	3.05	3.69	4.68	5.25
3250	1.69	2.51	3.00	1.90	2.82	3.41	4.32	4.85
3500	1.39	2.22	2.66	1.76	2.62	3.17	4.01	4.50
3750	1.15	1.94	2.32	1.64	2.44	2.96	3.74	4.20
4000	0.94	1.70	2.04	1.54	2.29	2.77	3.51	3.94
4250	0.80	1.52	1.82	1.45	2.15	2.61	3.30	3.71
4500	0.76	1.36	1.62	1.37	2.04	2.46	3.12	3.50
4750	0.72	1.21	1.45	1.30	1.93	2.33	2.95	3.32
5000	0.69	1.09	1.31	1.23	1.83	2.22	2.81	3.15
5250	0.65	0.99	1.18	1.17	1.74	2.11	2.67	3.00
5500	0.62	0.90	1.08	1.12	1.67	2.02	2.55	2.86
5750	0.59	0.81	0.97	1.07	1.59	1.93	2.44	2.74
6000	0.54	0.75	0.89	1.03	1.53	1.85	2.34	2.63

120mm TOP HAT DOUBLE SPAN UNLAPPED- INWARDS DESIGN CAPACITY (kN/m)

SPAN (mm)	MEMBER DESIGN CAPACITY FOR SECTION SHOWN					
	0.75		1.00		1.20	
	L/100	strength	L/100	strength	L/100	strength
2000	8.12	2.81	10.80	4.00	13.00	4.80
2250	5.70	2.49	7.59	3.53	9.10	4.22
2500	4.16	2.24	5.53	3.10	6.64	3.71
2750	3.12	2.03	4.16	2.71	4.99	3.24
3000	2.41	1.70	3.20	2.34	3.84	2.81
3250	1.89	1.39	2.52	2.06	3.02	2.46
3500	1.52	1.14	2.02	1.82	2.42	2.18
3750	1.23	0.94	1.64	1.59	1.97	1.90
4000	1.02	0.77	1.35	1.40	1.62	1.67
4250	0.85	0.66	1.13	1.25	1.35	1.49
4500	0.71	0.63	0.95	1.11	1.14	1.33
4750	0.61	0.59	0.81	0.99	0.97	1.19
5000	0.52	0.57	0.69	0.90	0.83	1.08
5250	0.45	0.53	0.60	0.81	0.72	0.97
5500	0.39	0.51	0.52	0.74	0.62	0.88
5750	0.34	0.48	0.45	0.67	0.55	0.80
6000	0.30	0.44	0.40	0.61	0.48	0.73

NOTE: Deflection limits can be used for both outward and inward loads.

22mm CEILING BATTEN SPAN TABLE (kN/m)

		SPAN	
		450	600
TRIPLE SPAN	Load Inwards	3.51	2.01
	Load Outwards	3.99	2.22
	Deflection (Span/150)	6.64	2.81

NON CYCLONIC MAXIMUM SPAN

Max. Span 1200mm

Max. Spacing 600mm

Supporting 1 layer of 10mm or 13mm plasterboard

FASTENERS

Fixing to Steel 10 - 16 x 16 HH Tek

Fixing to Timber M5.5 - 11 x 40 Batten Screws

120mm TOP HAT FLOOR JOIST SPAN TABLE

BMT (mm)	450mm CRS					
	SINGLE SPAN			DOUBLE LAPPED SPAN		
	1.5 kPa	3.0 kPa	5.0 kPa	1.5 kPa	3.0 kPa	5.0 kPa
0.75	2150	1400	900	2450	1450	900
0.95	2350	1950	1650	2650	2200	1650
1.15	2450	2050	1700	2750	2300	1900

SCREW PULLOUT CAPACITIES (kN/m)

DESIGN ASSUMPTIONS

1. All spans are equal.
2. Support member material is G450 steel.
3. Minimum edges distance = 3 times nominal screw diameter.
4. Minimum screw head diameter is in accordance with AS 3566.1

2 x 14G SCREWS PER SUPPORT

SPAN (mm)	SINGLE SPAN				DOUBLE SPAN ¹				TRIPLE SPAN ¹			
	SUPPORT MEMBER THICKNESS (mm) ²											
	0.75	0.95	1.15	1.5	0.75	0.95	1.15	1.5	0.75	0.95	1.15	1.5
1200	2.25	4.07	4.93	6.43	0.90	1.63	1.97	2.57	1.02	1.85	2.24	2.92
1500	1.80	3.26	3.94	5.14	0.72	1.30	1.58	2.06	0.82	1.48	1.79	2.34
1800	1.50	2.71	3.28	4.28	0.60	1.09	1.31	1.71	0.68	1.23	1.49	1.95
2100	1.29	2.33	2.82	3.67	0.51	0.93	1.13	1.47	0.58	1.06	1.28	1.67
2400	1.13	2.04	2.46	3.21	0.45	0.81	0.99	1.29	0.51	0.93	1.12	1.46
2700	1.00	1.81	2.19	2.86	0.40	0.72	0.88	1.14	0.45	0.82	1.00	1.30
3000	0.90	1.63	1.97	2.57	0.36	0.65	0.79	1.03	0.41	0.74	0.90	1.17
3300	0.82	1.48	1.79	2.34	0.33	0.59	0.72	0.94	0.37	0.67	0.81	1.06
3600	0.75	1.36	1.64	2.14	0.30	0.54	0.66	0.86	0.34	0.62	0.75	0.97
3900	0.69	1.25	1.52	1.98	0.28	0.50	0.61	0.79	0.32	0.57	0.69	0.90
4200	0.64	1.16	1.41	1.84	0.26	0.47	0.56	0.73	0.29	0.53	0.64	0.84
4500	0.60	1.09	1.31	1.71	0.24	0.43	0.53	0.69	0.27	0.49	0.60	0.78
4800	0.56	1.02	1.23	1.61	0.23	0.41	0.49	0.64	0.26	0.46	0.56	0.73
5100	0.53	0.96	1.16	1.51	0.21	0.38	0.46	0.61	0.24	0.44	0.53	0.69
5400	0.50	0.90	1.10	1.43	0.20	0.36	0.44	0.57	0.23	0.41	0.50	0.65
5700	0.47	0.86	1.04	1.35	0.19	0.34	0.42	0.54	0.22	0.39	0.47	0.62
6000	0.45	0.81	0.99	1.29	0.18	0.33	0.39	0.51	0.20	0.37	0.45	0.58

4 x 14G SCREWS PER SUPPORT

SPAN (mm)	SINGLE SPAN				DOUBLE SPAN ¹				TRIPLE SPAN ¹			
	SUPPORT MEMBER THICKNESS (mm) ²											
	0.75	0.95	1.15	1.5	0.75	0.95	1.15	1.5	0.75	0.95	1.15	1.5
1200	4.50	8.14	9.85	12.85	1.80	3.26	3.94	5.14	2.05	3.70	4.48	5.84
1500	3.60	6.51	7.88	10.28	1.44	2.61	3.15	4.11	1.64	2.96	3.58	4.67
1800	3.00	5.43	6.57	8.57	1.20	2.17	2.63	3.43	1.36	2.47	2.99	3.90
2100	2.57	4.65	5.63	7.34	1.03	1.86	2.25	2.94	1.17	2.11	2.56	3.34
2400	2.25	4.07	4.93	6.43	0.90	1.63	1.97	2.57	1.02	1.85	2.24	2.92
2700	2.00	3.62	4.38	5.71	0.80	1.45	1.75	2.29	0.91	1.64	1.99	2.60
3000	1.80	3.26	3.94	5.14	0.72	1.30	1.58	2.06	0.82	1.48	1.79	2.34
3300	1.64	2.96	3.58	4.67	0.65	1.18	1.43	1.87	0.74	1.35	1.63	2.12
3600	1.50	2.71	3.28	4.28	0.60	1.09	1.31	1.71	0.68	1.23	1.49	1.95
3900	1.38	2.50	3.03	3.95	0.55	1.00	1.21	1.58	0.63	1.14	1.38	1.80
4200	1.29	2.33	2.82	3.67	0.51	0.93	1.13	1.47	0.58	1.06	1.28	1.67
4500	1.20	2.17	2.63	3.43	0.48	0.87	1.05	1.37	0.55	0.99	1.19	1.56
4800	1.13	2.04	2.46	3.21	0.45	0.81	0.99	1.29	0.51	0.93	1.12	1.46
5100	1.06	1.92	2.32	3.02	0.42	0.77	0.93	1.21	0.48	0.87	1.05	1.38
5400	1.00	1.81	2.19	2.86	0.40	0.72	0.88	1.14	0.45	0.82	1.00	1.30
5700	0.95	1.71	2.07	2.71	0.38	0.69	0.83	1.08	0.43	0.78	0.94	1.23
6000	0.90	1.63	1.97	2.57	0.36	0.65	0.79	1.03	0.41	0.74	0.90	1.17

Can we assist with any additional
Steel Building Products?

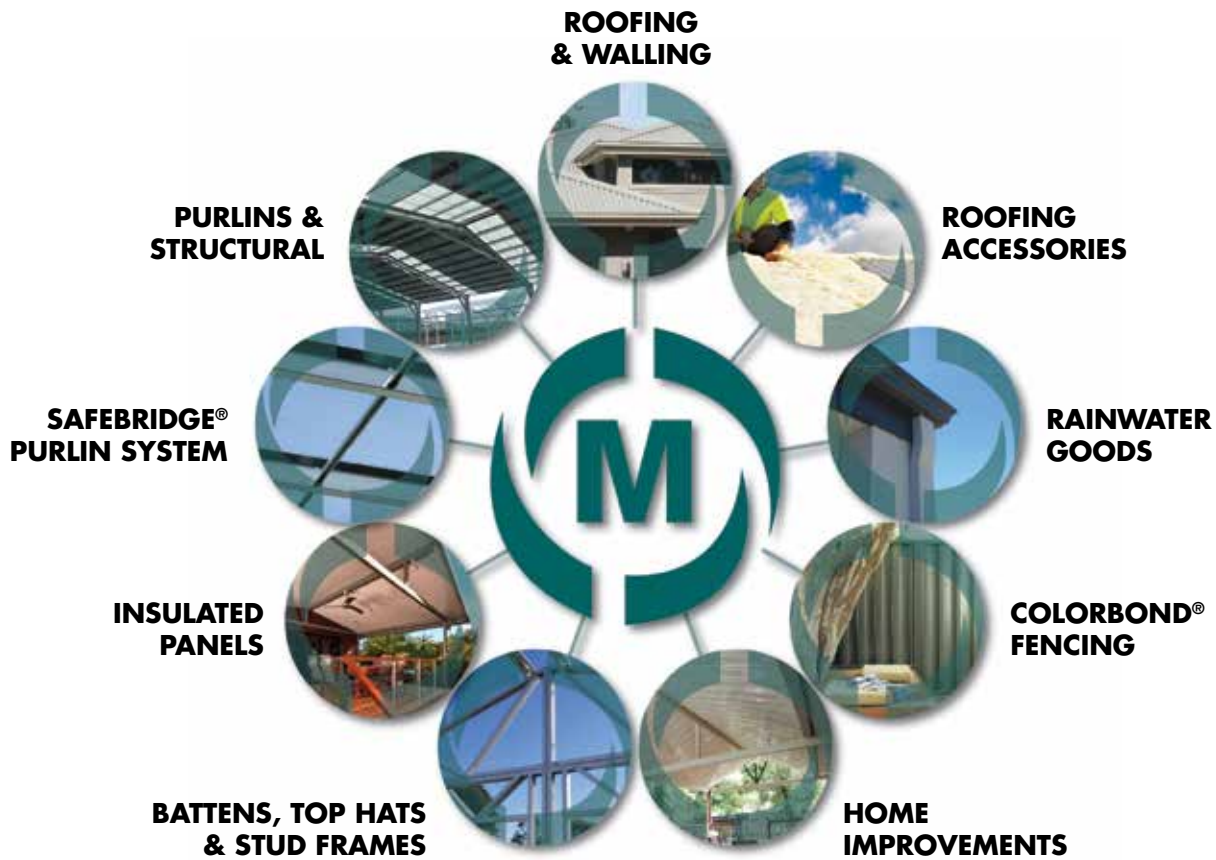

QLD

Cairns 07 4054 0888
Townsville 07 4779 8266
Mackay 07 4968 1255
Rockhampton 07 4920 0900
Bundaberg 07 4155 5999
Toowoomba 07 4634 6144
Sunshine Coast 07 5493 7872
Brisbane 07 3375 0100

NSW

Lismore 02 6622 6677
Tamworth 02 6765 4799
Newcastle 02 4954 5799
Sydney 1300 766 346
Dubbo 02 6883 4800
Wagga Wagga 02 5924 4500
Canberra 02 6298 2777
Albury 02 6043 6800

VIC

Sunshine 03 9480 3744
Laverton 03 8369 8300
Geelong 03 5248 2006
Ballarat 03 5335 6416
Pakenham 03 8710 9300
TAS
Hobart 03 6335 8555
Launceston 03 6335 8555

SA

Adelaide 08 8282 3300

NT

Darwin 08 8935 9555

WA

Kalgoorlie 08 9024 1388
Perth 08 9365 5444
Bunbury 08 9796 9796
Albany 08 9841 6966

29 Metroll Branches Nationwide

Visit our website
metroll.com.au



All reasonable care has been taken in the compilation of the information contained in this brochure. All recommendations on the use of Metroll products are made without guarantee as conditions of use are beyond the control of Metroll. It is the customers responsibility to ensure that the product is fit for its intended purpose and that the actual conditions of use are suitable. Metroll pursues a policy of continuous development and reserves the right to amend specifications without prior notice. The Metroll M and Logo are registered trademarks of Metroll. COLORBOND®, ZINCALUME®, GALVSPAN® steels are all registered trademarks of BlueScope Steel Limited.