

# LYSAGHT® FENCING

LYSAGHT

DESIGN & INSTALLATION GUIDE  
NON-CYCLONIC



INSPIRATION TO BUILD BETTER

# Contents

## FENCES & GATES - NON CYCLONIC

1.0	INTRODUCING OUR FENCING RANGE	3
2.0	COMPONENTS FOR FENCE ASSEMBLY AND INSTALLATION	4
3.0	AT THE START	6
4.0	FENCE SELECTION	7
5.0	SELECT FENCE POSTS AND CAPS	9
6.0	DETERMINE POST LENGTHS (3 INFILL SHEETS/PANEL)	10
7.0	FOOTINGS	11
8.0	INSTALLING A FENCE: STEP BY STEP	12
9.0	INSTALLING FENCE POSTS	13
10.0	PREPARING RAKED SECTIONS	14
11.0	INSTALLING 2 OR 3 INFILL SHEETS PER PANEL FENCES	15
12.0	INSTALLING 4 INFILL SHEETS PER PANEL FENCES	16
13.0	FINISHING OFF THE FENCE INSTALLATION	17
14.0	INSTALLING 'PLUS OPTION'	18
15.0	TAPERING ENDS OF FENCES	19
16.0	INSTALLING INFILL STRIPS AND POST CAPS	20
17.0	GATE SIZES, GATE COMBINATIONS AND GATE KITS	21
18.0	COMPONENTS FOR GATE ASSEMBLY AND INSTALLATION	22
19.0	INSTALLATION OF GATE POSTS AND GATES	23
20.0	GATE ASSEMBLY - PREPARATION STEPS (NEETASCREEN® & SMARTASCREEN® GATES)	24
21.0	GATE ASSEMBLY - (NEETASCREEN® & SMARTASCREEN® GATES)	25
22.0	GATE ASSEMBLY - PREPARATION STEPS (MINISCREEN® GATES)	27
23.0	GATE ASSEMBLY (MINISCREEN® GATES)	28
24.0	ADDING A 'PLUS OPTION' (LATTICE, SLATS) TO AN EXISTING LYSAGHT® FENCE	30
25.0	POST CAPS INSTALLATION	31

# FENCES & GATES



NEETASCREEN®



SMARTASCREEN®



MINISCREEN®

## LYSAGHT® FENCING RANGE

Product Availability	QLD	NSW	VIC	TAS	SA	NT	WA
NEETASCREEN® Standard	✓	✓	✓	✓	✓	✓	✓
NEETASCREEN PLUS® with Lattice	✓	✓	✓	✓	✓	✓	✓
NEETASCREEN PLUS® with Infill Slats		✓	✓				✓
SMARTASCREEN® Standard	✓	✓	✓	✓			✓
SMARTASCREEN PLUS® with Lattice	✓	✓	✓	✓			✓
SMARTASCREEN PLUS® with Infill Slats		✓	✓				✓
MINISCREEN® Standard	✓	✓	✓	✓			✓
MINISCREEN PLUS® with Lattice	✓	✓	✓	✓			✓
MINISCREEN PLUS® with Infill Slats		✓	✓				✓

NOTE: Non-cyclonic fences only. For cyclonic areas, refer to the LYSAGHT® Cyclonic Area Fence Design & Installation Guide.

# 1.0 INTRODUCING OUR FENCING RANGE

## THE FACTS BEHIND LYSAGHT® STEEL FENCING

Boundary fences are one of the most visible features of many homes – and also one of the most exposed to the elements. That’s why the fence you choose needs to be attractive, strong and designed to last.

Choose a LYSAGHT® steel fence solution from Lysaght and you can be confident that over 40 years of steel fencing experience will ensure you get a fence that will not only look great when you install it but will give you peace of mind for years to come.

## INTRODUCING THE NEW 4 SHEET/PANEL LYSAGHT® FENCE RANGE

LYSAGHT® steel fences in non-cyclonic regions are now even better looking with the introduction of the 4 infill sheet per panel design. With panels 33% wider than the traditional 3 sheet panel system, there are fewer posts to interrupt the clean lines of a long run LYSAGHT® steel fence. With fewer post holes to dig installation can be quicker and even more economical with less concrete footings required.

## DESIGNED FOR STYLE

LYSAGHT® steel fences are available in a range of styles and COLORBOND® steel colours to suit every Australian home. Complemented by a range of accessories, such as gates and lattice, you can be confident of finding the perfect fence for your home.

## THREE STYLES ARE AVAILABLE;

1. Traditional NEETASCREEN® - our first and still our most popular style
2. Neighbour friendly SMARTASCREEN® - with its clean attractive lines and subtle textured finish, this style has the same great look on both sides
3. Stylish MINISCREEN® - with its sophisticated mini-corrugated profile

## HEIGHTS FOR EVERY BACKYARD

LYSAGHT® steel fences are available in standard heights of 1500, 1800 and 2100mm and can be installed on flat and sloping grounds.

## BUILT TO LAST

Designed to Australian Standards, fully engineered and wind pressure tested to Australian wind loading standards in our NATA-accredited facility, LYSAGHT® steel fences combine a unique post and rail system with hi-tensile 0.35mm BMT steel infill sheets to produce one of the strongest steel boundary fences on the market.

The deep rail system of a LYSAGHT® fence also gives greater latitude for installation of raked fences on sloping ground.

## PROVEN IN AUSTRALIA

Because your LYSAGHT® steel fence is guaranteed to be manufactured using genuine COLORBOND® steel, the only pre-painted steel fencing material with over 40 years of proven performance in Australia’s harsh conditions, you can be assured that your fence will look great for years to come.

## BACKED BY A REAL WARRANTY

A LYSAGHT® steel fence gives you real peace of mind. Not only do we offer a material warranty backed by one of Australia’s leading manufacturers - BlueScope, but our comprehensive product testing enables us to offer a 10 year structural fencing warranty for all regions in Australia.

1. The LYSAGHT® 10 Year Fencing Warranty covers the structural integrity of your complete fence system and is your guarantee that your fence will remain standing for years to come; and
2. A separate COLORBOND® steel warranty covers the material used to manufacture your LYSAGHT® steel fence against corrosion to perforation by natural weathering and against paint flake and peel.

\* When the fence is installed and maintained according to COLORBOND® steel and LYSAGHT® steel fencing specifications.

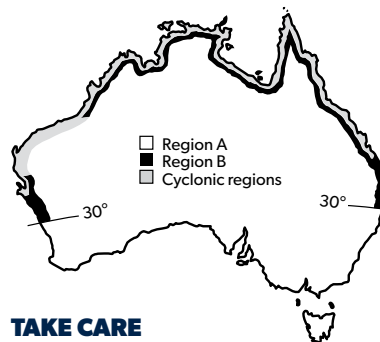
For further information on the warranties available for a LYSAGHT® fence and eligibility, visit [www.lysaght.com/warranty](http://www.lysaght.com/warranty).

## MAKE THE RIGHT CHOICE

The products and instructions in this guide are for LYSAGHT® fence installations all over Australia except for tropical cyclone regions defined in AS/NZS 1170.2 Structural Design Loads, Part 2; Wind Loads (See map Figure 1.1). Refer to our cyclonic fencing guide for use in these regions.

## FIGURE 1.1:

Wind regions based on AS/NZS 1170.2



## TAKE CARE

LYSAGHT® steel fences are easy to maintain, a simple regular wash down with fresh water is all they need. While your fence will have good resistance to accidental spillage of solvents they should not be installed within one kilometre of marine, severe industrial or other corrosive environments. Similarly both saltwater and freshwater swimming pools contain corrosive chemicals and you should be aware that your warranty does not cover damage resulting from your fence or gate being splashed with contents of the swimming pool. Fence and gate panels must be installed clear of the ground.

This is a step-by-step guide for the selection and installation of LYSAGHT NEETASCREEN®, SMARTASCREEN® and MINISCREEN® steel fences and matching gates.

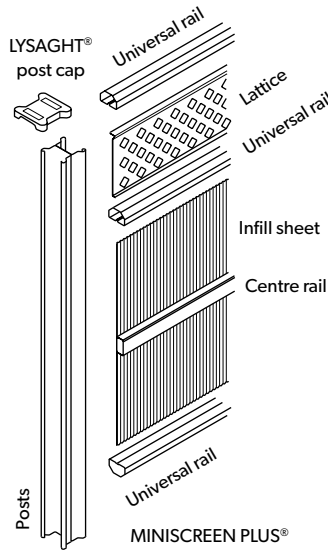
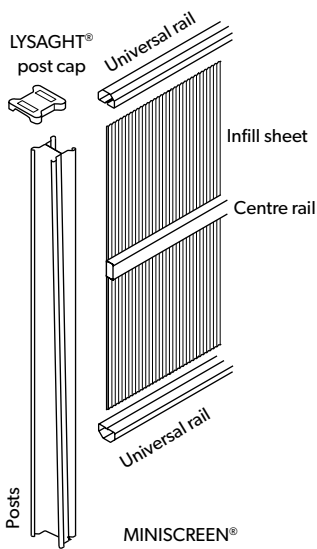
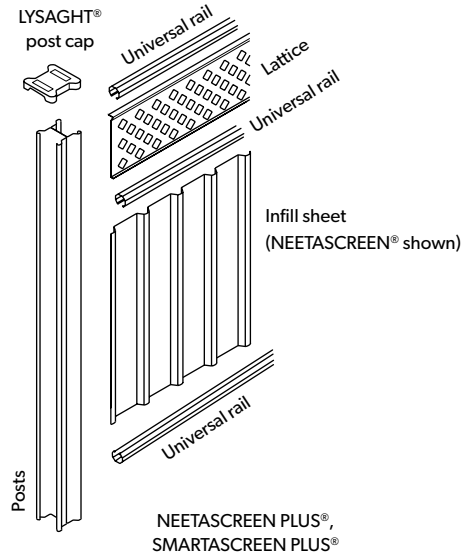
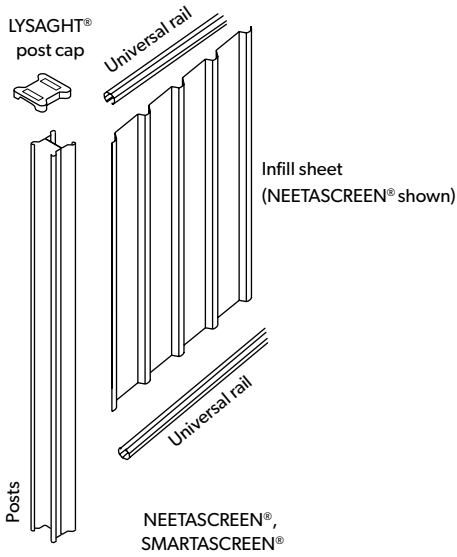
When NEETASCREEN® and SMARTASCREEN® fences comprising up to four infill sheets per panel are combined with attractive steel lattice, they are called NEETASCREEN PLUS® and SMARTASCREEN PLUS®.

MINISCREEN PLUS® can have up to three infill sheets per panel. Also included are instructions to convert suitable standard fences to a 'PLUS' fence through retro-fitting a 'PLUS Option' lattice.

# 2.0 COMPONENTS FOR FENCE ASSEMBLY AND INSTALLATION

Detailed below is the componentry required for assembly and installation of your new fence panels. Ensure you determine the best option and required components from the following pages prior to placing your order. Gate components can be found in

Section 18 of this manual. Please check with your local LYSAGHT® fencing supplier for availability of components in your area.



## Infill Sheet Styles

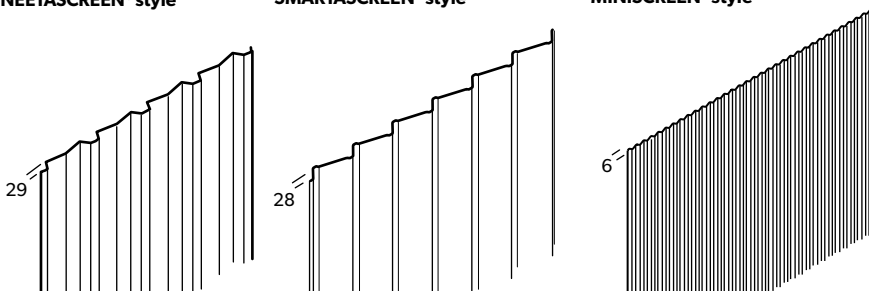
Standard lengths: 1490, 1790 & 2090mm

Standard lengths for 'PLUS': 1190, 1490 & 1790mm

NEETASCREEN® style

SMARTASCREEN® style

MINISCREEN® style

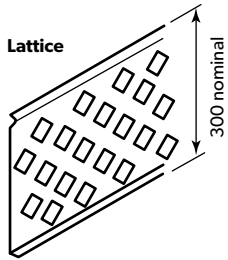
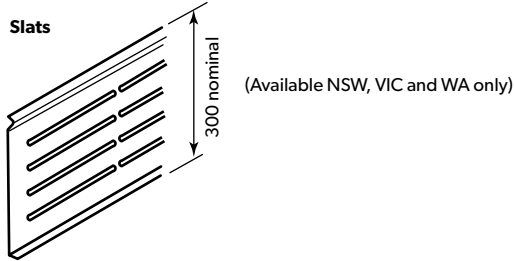


**FIGURE 2.1:**

Components.

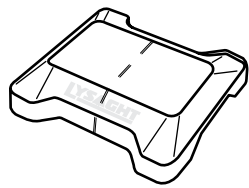
**'PLUS' Options**

NEETASCREEN PLUS  
SMARTASCREEN PLUS  
MINISCREEN PLUS



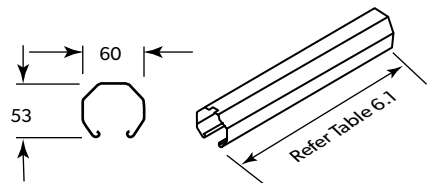
**Post Caps**

LYSAGHT® Post Cap

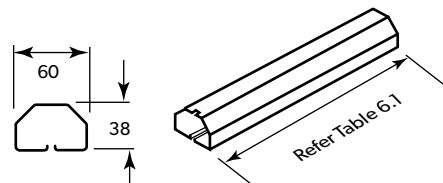


**Rails**

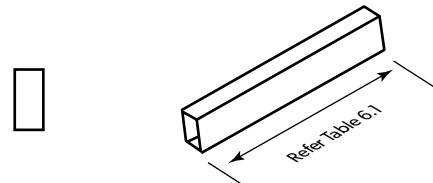
NEETASCREEN® and SMARTASCREEN® Universal Rail



MINISCREEN® Universal Rail



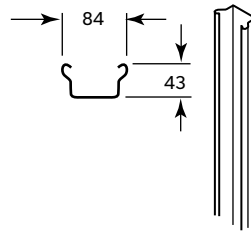
MINISCREEN® Centre Rail



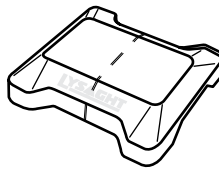
**Standard Post**

LYSAGHT® Posts

Standard lengths:  
2100, 2400, 2700 & 3000mm

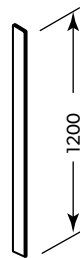


LYSAGHT® Post Cap

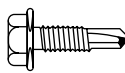


Flat Post Stiffener

3mm



**Fasteners**



Self-drilling, self tapping hex.  
washer-head screws 10-16x16

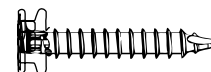
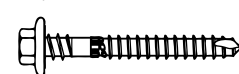


Self-drilling, self tapping,  
long drill bit hex. head screw  
12-24x32

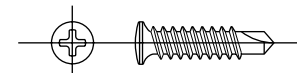
Ripple Screws  
(MINISCREEN® range only)



RippleZip® screw  
or M4.8-16x25



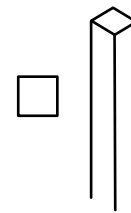
Self-drilling, self tapping, hex. head  
screw 12-14x45 or RoofZips M6-11x50  
or AutoTek's M5.5-14x50



Ripple Tek® screw  
10-16x20

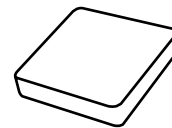
Square (Tubular) Post

60 x 60 x 1.6, 65 x 65 x 2.5  
Standard lengths: 2400, 3000



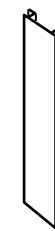
Square (Tubular) Post Cap

(for square post) 60 x 60, 65 x 65



Post Cover Strip

Standard length: 2400 mm



# 3.0 AT THE START

## BEFORE YOU ORDER

- The next five pages are about selecting the right components in order to get the fence you want. This includes choosing the right fence type, post lengths and infill profile.
- Decide if you prefer NEETASCREEN®, NEETASCREEN PLUS®, SMARTASCREEN®, SMARTASCREEN PLUS®, MINISCREEN® or MINISCREEN PLUS®
- Decide the height of your fence 1500, 1800 or 2100mm high.
- Choose your components as listed in the order guide on this page.
- The subsequent pages detail how to install your fence.

## BEFORE YOU START WORK

- Read this guide.
- Check you have the correct components for the type of fence you are installing.
- Check where you intend to dig that there are no underground electricity, telephone, gas or water mains.
- Check you have the appropriate tools that you need for a safe installation.

## EQUIPMENT YOU NEED

Ensure all equipment is suitable for the job and you are familiar with the safe operation procedure of the equipment

- Screw gun (or power drill) with torque adjustment
- Marker, coloured pencils, chalk - not black pencil
- Tape measure
- Rubber mallet
- Stringline and marker pegs
- Shovel and/or spade
- Spirit level
- Personal protective equipment including safety clothing, gloves and glasses, ear protection, sun protection
- Sharp knife
- Tin snips (if cutting required)
- Hacksaw with fine tooth blade (optional)
- Nibbler (optional if cutting required)
- Power saw with metal cutting blade (optional if cutting required)
- Concrete mixer (optional)
- Posthole digger (optional)

## COMPONENTS

Our new range of fences introduce four panel fences (4 infill sheets per panel) and the example in the next column refers only to NS4 (no stiffener and 4 infill sheet/panel) fences, except as noted.

## POSTS AND POST CAPS

Each standard fence panel is supplied with two standard posts. However, depending on how you configure corners and ends of fence runs, you might need extra standard posts or some square posts (Figure 5.1).

Your selection of these extra posts will affect the number and type of additional post caps.

## ORDER GUIDE

### STANDARD COMPONENTS

A standard NS4 fence (No post stiffener, 4 infill sheets/panel) consists of the following components:

### NEETASCREEN® AND SMARTASCREEN® NS4 COMPONENTS

- 2 Standard posts
- 2 NEETASCREEN® or SMARTASCREEN® universal rails
- 4 NEETASCREEN® or SMARTASCREEN® infill sheets
- 1 LYSAGHT® post cap\*
- 17 self-drilling hex. head screws #10-16x16
- 2 self drilling hex. head screws #12-14x45

### NEETASCREEN PLUS® AND SMARTASCREEN PLUS® NS4 COMPONENTS

- 2 Standard posts
- 3 NEETASCREEN® or SMARTASCREEN® universal rails
- 4 NEETASCREEN® or SMARTASCREEN® infill sheets
- 1 Lattice
- 27 self-drilling hex. head screws #10-16x16
- 2 Self drilling hex. head screws #12-14x45
- 2 Post infill strips (optional)

### MINISCREEN® NS3 COMPONENTS

- 2 Standard posts
- 2 MINISCREEN® universal rails
- 1 Centre rail
- 3 MINISCREEN® infill sheets
- 1 LYSAGHT® post cap\*
- 17 self-drilling hex. head screws #10-16x16
- 7 Ripple Tek or RippleZip screws

### MINISCREEN PLUS® NS3 COMPONENTS

- 2 Standard posts
- 3 MINISCREEN® universal rails
- 1 Centre rail
- 3 MINISCREEN® infill sheets
- 1 Lattice
- 27 self-drilling hex. head screws #10-16x16
- 7 Ripple Tek or RippleZip screws
- 2 Post infill strips (optional)

\* You may need to order extra caps depending on your post configurations (Figure 5.1).

NOTE: Gates are dealt with separately at the back of this manual.

FS2, FS3 and FS4 fences contain the addition of a post stiffener. FS4 fences have added fasteners to connect the rails to the infill sheets.

Cyclonic fences are detailed in a separate manual: Cyclonic Area Design and Installation Guide.

# 4.0 FENCE SELECTION

It is important to make your fence selection based on both your aesthetic requirements, and the suitability to the environment your fence is to be erected. Ensure you get a long lasting, value adding boundary fence by following the guidelines below:

## INSTALLATION ENVIRONMENT

Steel fences should not be installed within 1km of marine, severe industrial or other corrosive environments. Take extreme care if the fence is near a swimming pool because pool water splashed on the fence will void the warranty.

The fence bottom rail must be installed clear of the ground to ensure longevity.

These fences are not to be used as a retaining wall.

### 1. DETERMINE YOUR WIND REGION

The information in this guide is suitable for use only in regions A and B of AS/NZS 1170.2 Structural Design Loads, Part 2: Wind Loads (Figure 1.1). Cyclonic regions are covered in our cyclonic fence guide. If you have any doubt about the region your fence will be in, get advice from your local building consent authority.

### 2. DETERMINE YOUR TERRAIN CATEGORY

Select the terrain category that best describes the area in which your fence will be erected from the categories listed below. Use this information to determine the type of fence required. Use Table 4.1 or 4.2 to choose the appropriate fence infill styles.

If you want to build on the top of a hill, adjacent to an escarpment, on a ridge, or in Terrain Category 1, you need engineering advice beyond the scope of this publication.

**FIGURE 4.1:**

Terrain Categories.



#### Terrain Category 2

Open terrain including sea coast areas, airfields, sports fields, grassland with a few well-scattered obstructions, such as isolated trees and uncut grass, having heights generally from 1.5 to 10m, and water surfaces. Typically acreage-suburbia with less than 10 houses per hectare.



#### Terrain Category 2.5

Terrain with a few trees, isolated obstructions (for example agricultural land, canefields or long grass to 0.6 m). This category is typical of developing outer urban areas. Less than 10 houses per hectare; or more than 10 houses per hectare, 500m apart and in two rows.



#### Terrain Category 3

Terrain with numerous closely spaced obstructions the size of domestic houses 3 to 5m high. Typically residential-suburbia with ten or more houses per hectare.

**TABLE 4.1:**

Standard Fence Styles.

Nominal Fence Height (mm)	Terrain Category	Wind Regions	
		A	B
		Fence type Infill sheet style	Fence type Infill sheet style
1500 & 1800	2	FS4 NS,SmS	FS3 SmS
	2.5	NS4 NS,SmS	FS4 NS,SmS
	3	NS4 NS,SmS	NS4 NS,SmS
2100	2	FS3 NS,SmS	N/A N/A
	2.5	NS3 NS,SmS	FS2 NS,SmS
	3	NS3 NS,SmS	FS3 NS,SmS

Note:  
NS- NEETASCREEN, SmS- SMARTASCREEN, FS- Flat Post Stiffener, NS- No Post Stiffener

**TABLE 4.2:**

Premium Fence Style.

Nominal Fence Height (mm)	Terrain Category	Wind Regions	
		A	B
		Fence type Infill sheet style	Fence type Infill sheet style
1500 & 1800	2	NS3 MS	N/A N/A
	2.5	NS3 MS	NS3 MS
	3	NS3 MS	NS3 MS
2100	2	FS3 MS	N/A N/A
	2.5	NS3 MS	FS2 MS
	3	NS3 MS	FS3 MS

**FIGURE 4.2:**

Fence types and infill styles.

**KEY TO FENCE TYPES**

(FS2, NS3, FS3, NS4 or FS4)

In non-cyclonic areas, there are 2 fence types, depending on the post requirements:

Type NS = No Post Stiffener

Type FS = Flat Post Stiffener

**Number of infill sheets per panel**

Number (2, 3 or 4) = Number of infill sheets per panel.

MINISCREEN® is available only in 2 or 3 infill sheets per panel.

**Standard Fence Styles**

NEETASCREEN® (NS)

SMARTASCREEN® (SmS)

**Premium Fence Style**

MINISCREEN® (MS)

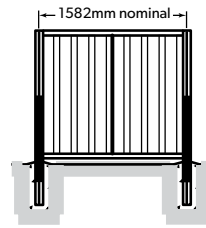
(Not suitable for a 4 infill sheet/panel fence)

**CHOOSE A FENCE WITH OR WITHOUT A 'PLUS OPTION'**

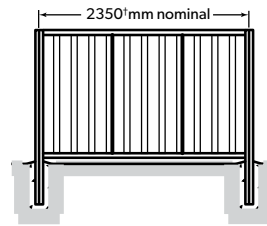
There are two options: lattice or slats. Check local availability of 'PLUS Options' in your area.

Example: Wind Region A, Terrain Category 3 means an NS4 fence would be suitable. Select a suitable infill sheet style from Table 4.1 (for Standard fences: NEETASCREEN® or SMARTASCREEN®) or use Table 4.2 for a premium fence (MINISCREEN®).

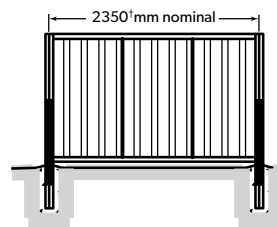
**Fence Type FS2**  
(2 infill sheets, flat post stiffener)



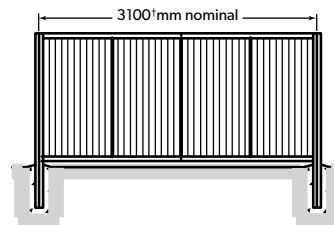
**Fence Type NS3**  
(No stiffener, 3 infill sheets)



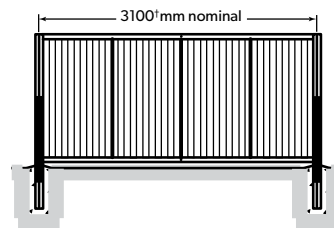
**Fence Type FS3**  
(3 infill sheets, flat post stiffener)



**Fence Type NS4**  
(No stiffener†, 4 infill sheets, infills screwed to rails at mid-point)

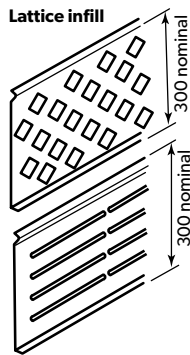


**Fence Type FS4**  
(4 infill sheets, flat post stiffener, infills screwed to rails at mid-point)

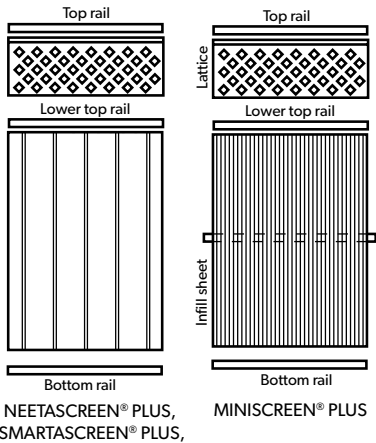


†Rail lengths vary. Refer to Table 6.1.

**'PLUS' Options**



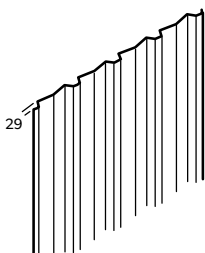
**Slats infill**  
(Available NSW, VIC, WA only)  
Total lengths refer Table 6.1.



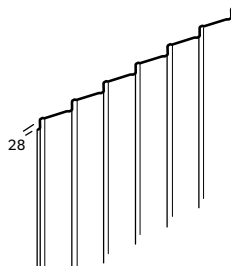
**Infill Sheet Styles**

Standard panel heights: 1490, 1790 & 2090mm  
Standard heights for 'PLUS': 1190, 1490 & 1790mm

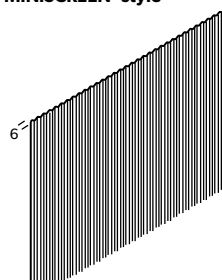
**NEETASCREEN® style**



**SMARTASCREEN® style**



**MINISCREEN® style**





# 5.0 SELECT FENCE POSTS AND CAPS

## SELECTION OF POSTS

Check the number and type of posts you will need, starting with a sketch of your fence site. Mark on it the type of posts you will need (Figure 5.1).

You will need to consider:

- If the fence will be 2, 3 or 4 infill sheets for each panel;
- Posts in a fence run that don't form a corner (typically at the front of a property next to road);
- Intermediate posts (they are always two standard LYSAGHT® posts screwed back-to-back);
- The various configurations of posts at corners;
- If the fence is to be stepped;
- If the ends of the fence are to be tapered (Section 15);
- Gate posts

## SELECTION OF POST CAPS

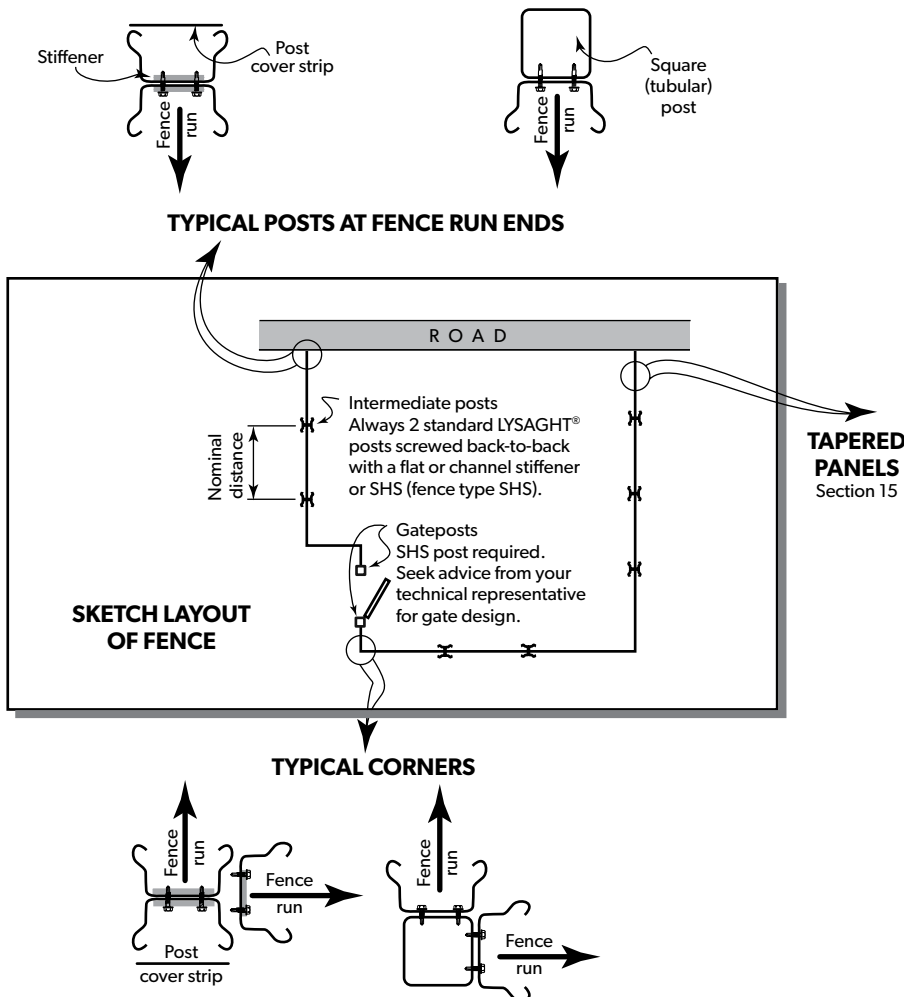
Fix post caps on all fence posts to give the perfect finishing touch and to protect against any sharp edges (Section 16). Choose your post caps based on your post configurations and personal preference.

**LYSAGHT® Post Caps** fit two standard LYSAGHT® posts screwed back-to-back. For a single standard post, it is easy to cut a cap in half with a sharp knife in the groove moulded into the underside—trim the edges straight.

**Square Post Caps** suit square posts and are usually used at corner junctions and gate openings.

**Figure 5.1:**

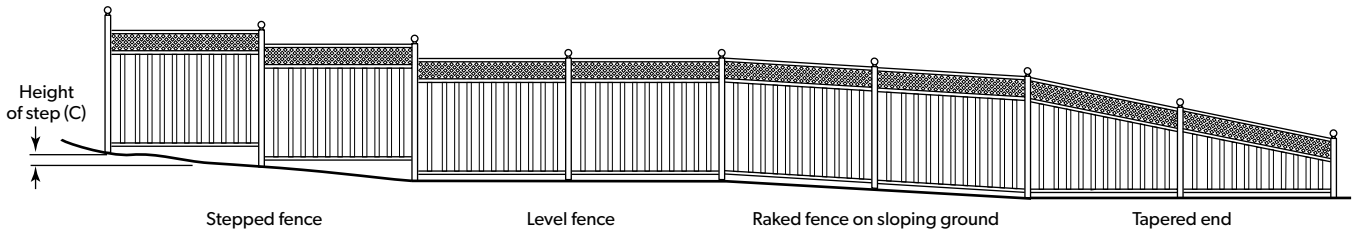
Preliminary selection of posts.



# 6.0 DETERMINE POST LENGTHS

**FIGURE 6.1:**

Fence installations.



If the ground is not all level, consider whether the fence will be stepped or raked (Figure 6.1). For aesthetic reasons, people often choose to step rather than to rake when using a lattice.

Fences may be installed raked on slopes of 1 in 20. Refer to Table 10.1 for measurements.

For steeper slopes you will need to:

- step your fence; or
- cut the infill sheets, lattices and rails (Section 10).

If some of the ground is level and some sloping, or if the slope varies markedly, you might need posts of different lengths.

### DETERMINE BASIC POST LENGTHS

Refer to Table 6.2. (For data on tapered ends refer Section 15.)

Basic post length = (Footing depth – 40) + (Height above ground)

(NOTE: 4 infill sheet/panel fences must not exceed 1800mm)

Get the footing depth from Section 7, and height above ground from:

$$\text{Height of post above ground} = A + B + C$$

Where:

A = Nominal fence height (Figure 6.2)

B = 50mm ground clearance (Figure 6.2)

C = If a stepped installation: height of the step (Figure 6.1)

### SELECT STANDARD LENGTHS

Use Table 6.2 below to select the lengths you need to order. The standard post lengths are 2100, 2400, 2700 and 3000mm.

**TABLE 6.1:**

Panel width.

	4 Infills	3 Infills	2 Infills
NEETASCREEN®	3100	2350	1582
SMARTASCREEN®	3100	2350	1582
MINISCREEN®	-	2350	1582

**Table 6 .2:**

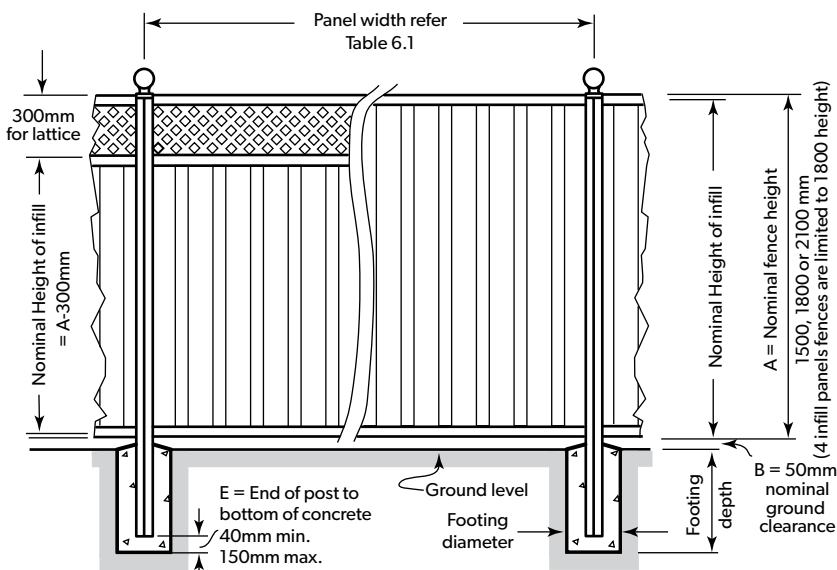
Length of posts required.

Calculated basic post length	Length of standard post to use	
	Minimum (mm)	Maximum (mm)
2100	2210	2100
2211	2399	2400*
2400	2510	2400
2511	2699	2700*
2700	2810	2700
2811	2999	3000*
3000	3110	3000

\*Cut so that dimension E in Figure 6.2 is between 40 and 150mm.

**FIGURE 6.2:**

Panel arrangement (NEETASCREEN® shown).



# 7.0 FOOTINGS

## SELECT YOUR MINIMUM FOOTING DEPTH

Your fence posts must be embedded in concrete footings of adequate size. Footings must not be placed in uncompacted fill. All footings in Table 7.1 are 200mm diameter.

## DEPTH OF FOOTINGS

**TABLE 7.1:**

Footings depth for fencing by wind region (mm).

Nominal Fence Height	Wind Region	Terrain Category	Soft Clay, Loose Sand			Medium Dense Sand			Rock		
			Fence length (sheets)			Fence length (sheets)			Fence length (sheets)		
			2	3	4	2	3	4	2	3	4
1500 & 1800mm	A	2	600	700	900	300	500	500	200	300	300
		2.5	400	600	700	300	400	400	200	200	300
		3	400	500	600	200	300	400	100	200	200
	B	2	700	900	-	400	600	-	300	400	-
		2.5	600	700	900	300	500	500	200	300	300
		3	400	600	700	300	400	400	200	200	300
2100mm	A	2	600	800	-	400	500	-	200	300	-
		2.5	500	600	-	300	400	-	200	300	-
		3	400	500	-	200	300	-	200	200	-
	B	2	-	-	-	-	-	-	-	-	-
		2.5	600	-	-	400	-	-	200	-	-
		3	500	600	-	300	400	-	200	200	-

Footing diameter = 200mm for Regions A and B.

### EXAMPLE

#### Givens

1. Site in a Sydney built-up suburb.
2. Wind region: Region A
3. Terrain category: Established residential area – Terrain Category 3
4. Soil type: Stiff clay
5. Fence height: 1800mm

#### Solution

Fence Type NS4 may be used at this site (Section 4)

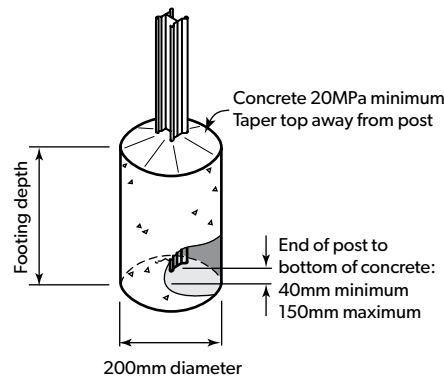
Footing required is: 200mm diameter x 400mm deep

Soil around posts footings shall be compacted as necessary to achieve minimum allowable bearing capacity:

- Soft clay, loose sand = 100kPa
- Medium dense sand and gravel, stiff clay = 200kPa
- Rock = 400kPa

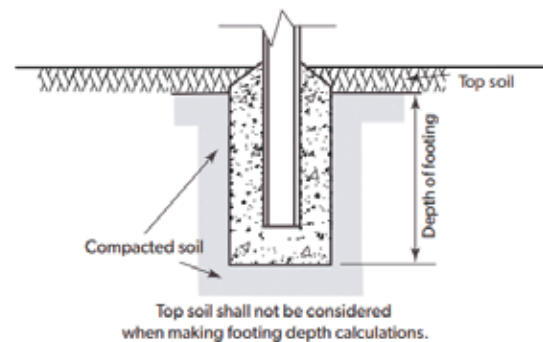
**FIGURE 7.1:**

Footing dimensions.



**FIGURE 7.2:**

Footing depth.



# 8.0 INSTALLING A FENCE: STEP BY STEP

So far we have talked about selecting your fence. The following section discusses step by step, how to prepare and install your LYSAGHT® fence.

## WHAT KIND OF SITE DO YOU HAVE?

Work out your levels. Is it one straight run, or are there raked or stepped sections?

## MAKING UP POSTS

Start by making up posts by screwing them together. Screwing the posts together requires seven staggered screws. (Refer Figure 8.1).

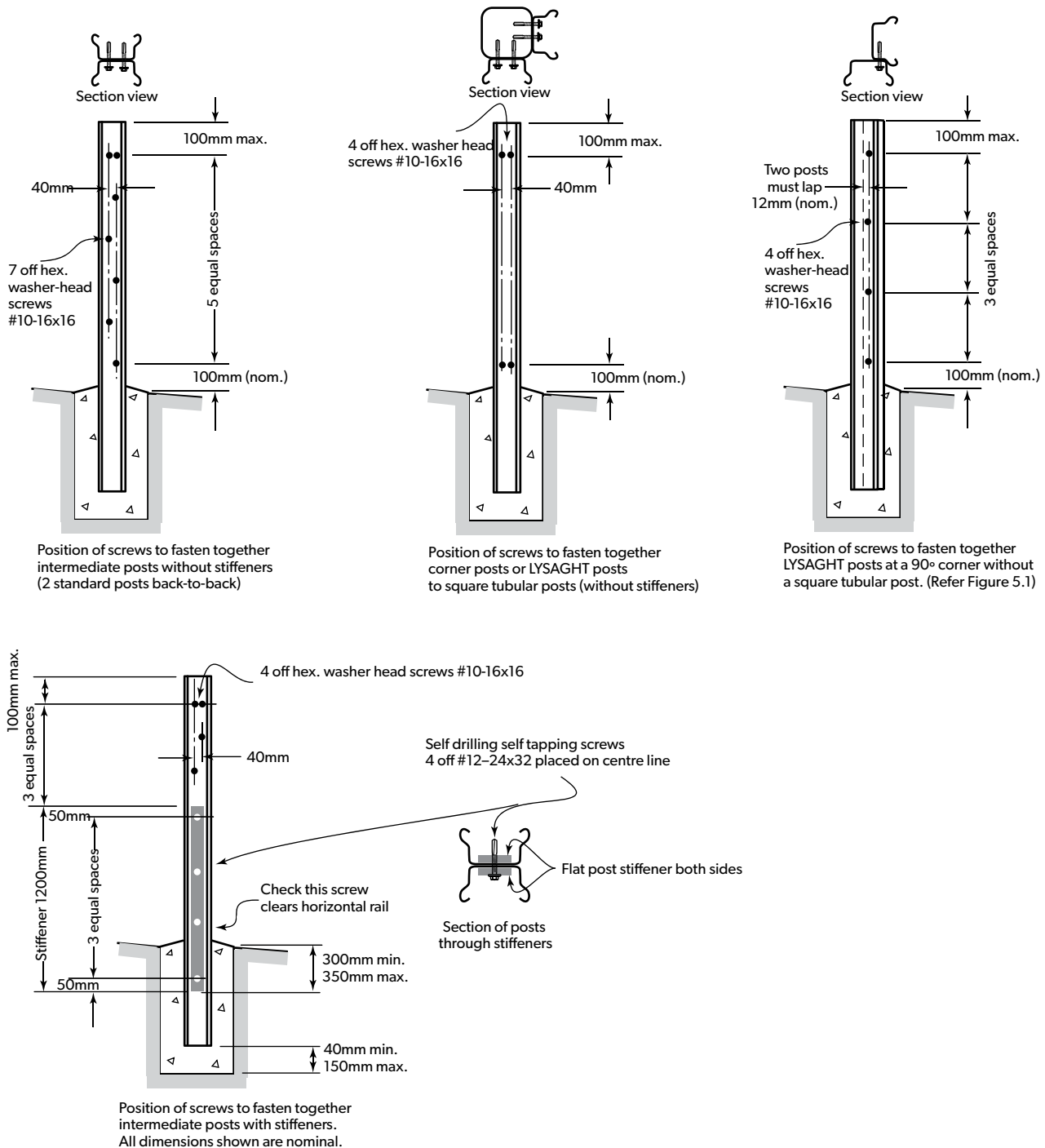
As a tip, bring your top screw down so it sits below your top rail. Otherwise your top rail is going to get stuck on it every time you go to fit it in. (Refer Figure 8.1).

TIP: Use 'G' clamps to hold stiffeners and post in place.

Make up the required number of posts. For Fence Type FS4, post stiffeners must be fitted (Figure 8.1). If using stiffeners, screw into place while making up posts.

**FIGURE 8.1:**

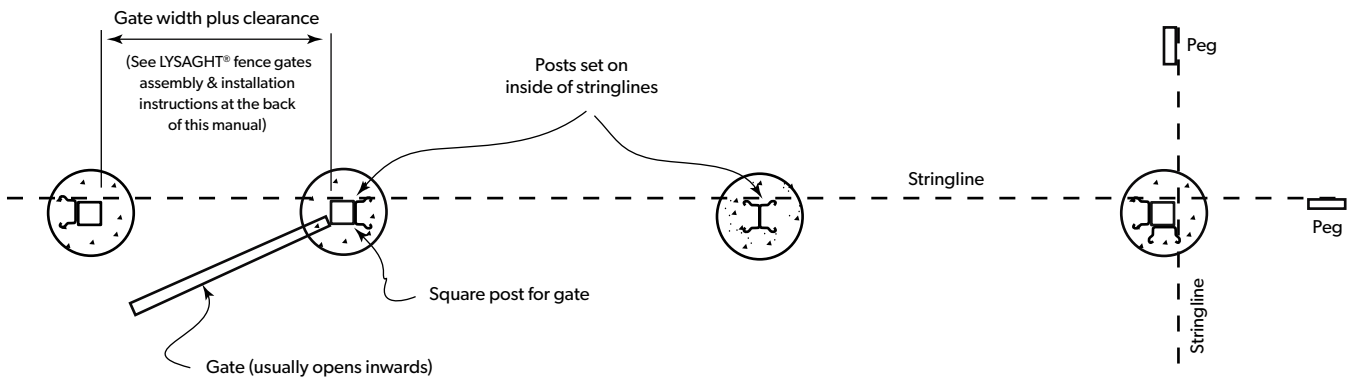
Fastening posts together.



# 9.0 INSTALLING FENCE POSTS

**FIGURE 9.1:**

Stringline layout.



## 1. LAYOUT STRINGLINES TO POSITION YOUR FENCE

Stringlines mark the outside line of your fence posts (Figure 9.1), and help to set your fence posts at a uniform height.

Determine the exact location of your fence and setup a stringline. Keep the stringline taut and set at the top of two end posts. Place the stakes 500mm beyond the corners of the fence, so as not to obstruct the holes.

## 2. LAYOUT POSTS AND DIG HOLES

Mark the position of fence posts. Lay the rails on the ground butting end to end between the two end posts so you can see exactly where your posts are going to go. For raked sites, longer rails may need to be used. Refer to the raked section in Section 10.

If there is to be a gate, locate the gate posts as detailed in LYSAGHT® fence gates assembly and installation guide at the back of this manual.

A fence panel can be reduced from the nominal width, without cutting infill sheets, by the increments shown in Figure 13.2. Rails and lattices must be cut to suit a narrow fence panel.

Dig the holes using the hole sizes determined (Section 7).

## 3. PLACE THE FIRST POST

If the ground slopes, start at the high end.

Lay a minimum of 40mm concrete under the end of the post and set your post into the hole. This should be done for every post. Fill the hole with concrete and use your spirit level to get the post plumb. Tamp the concrete down. Ensure that the concrete tapers away from the post. (Figure 7.1). Be careful that concrete doesn't contact the rails above ground.

**Figure 9.2**

Placing remaining posts.

## 4. PLACE REMAINING POSTS

Place the second post in its hole and engage a bottom rail with the first and second post. Make sure the bottom rail is 50mm above the finished ground.

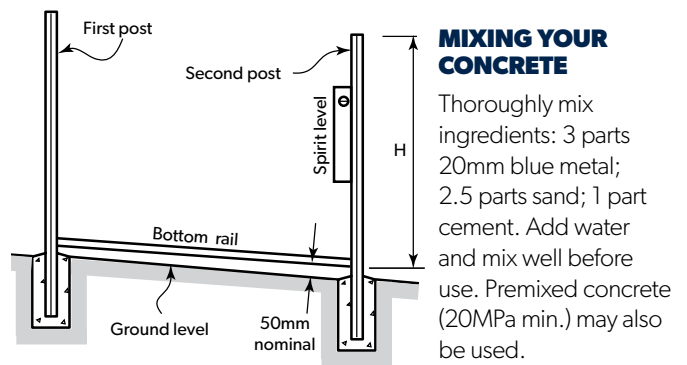
A tip is to give the rails a squeeze when you're putting them into or out of your post. This helps prevent scratching.

Fasten the bottom rail with one hex. head screw (#10-16x16) from both sides of each post.

Use the stringline to ensure your posts are all the correct height, plumb and in line, before concreting into position.

Wait at least 24 hours for the concrete to dry before installing infill sheets.

Continue installation of posts and bottom rails for the remainder of the run.



Use stringline to set post heights.



Lay the rails along the string line to determine positions of posts.



Set all the bottom rails into position ensuring a 50mm ground clearance.

# 10.0 PREPARING RAKED SECTIONS

If your fence requires raked sections, you may need to prepare the rails and infill sheets. If your fence is level or stepped, skip ahead to the infill installation instructions.

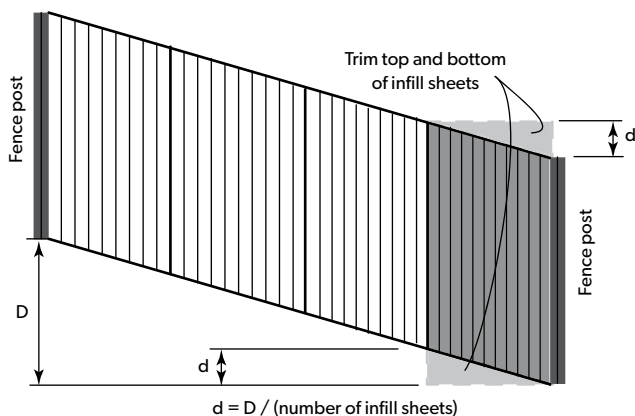
## PREPARING RAKED RAILS

For small rakes (<150mm), the increase in the length of top and bottom rails can be ignored. An approximate length of raked rail is shown in the adjacent table. A rail of 3300mm (and a 'PLUS Option') are available for this purpose.

The length to cut these raked sections is detailed in the table at right, once you have determined the height of the cut.

### FIGURE 10.1:

Cutting infill sheets for a 4 infill sheets/panel raked fence. Refer to Section 6 for calculation.



## PREPARING INFILL SHEETS

Work out the measure of the cut by resting your spirit level inside the rail (at least the width of a sheet) at the high end of the rail (Refer photo). Measure the width of a sheet, and measure the distance with your tape between the bottom of the level and the inside of the rail. That will show you the angle of your cut. Wherever possible, make the rake on the bottom rail the same as the top.

Measure the height of your fence up from your cut edge and cut at the same angle at the top of the sheet.

Use a coloured pencil, marker or chalk to mark the cut, as a pencil may cause corrosion.

Stack and cut the infill sheets in panel multiples (i.e. for a three infill panel fence, stack and cut three sheets at a time). This ensures uniformity. Measure twice, cut once.

Fine tune rails before screwing them into position.

Ensuring the rails are aligned, and the sheets are neat vastly improves the appearance of your fence.

Once you have installed all the bays, stand back from the fence and have a look at the fence as a whole.

Make sure the lines on your sheets run parallel to your posts. Make sure the joint of the overlap looks flush, without a big gap. Adjust where required.

Screw the rails into position.

Remove any swarf from the installation.

**Table 10.1:**

Raked rail lengths.

### (4 Infill Sheets/Panel) Fence Types

Raked Rail Length Approx.		Infill Sheet Cut (d)
Height of Step	NS/SmS (mm)	NS/SmS (mm)
0	3100	-
150	3104	37.5
250	3110	62.5
300	3114	75
350	3119	87.5
400	3125	100

### (3 Infill Sheets/Panel) Fence Types

Raked Rail Length Approx.		Infill Sheet Cut (d)
Height of Step	NS/SmS/MS (mm)	NS/SmS/MS (mm)
0	2350	-
150	2354	50
250	2363	83
300	2369	100
350	2375	116
400	2383	133

### (2 Infill Sheets/Panel) Fence Types

Raked Rail Length Approx.		Infill Sheet Cut (d)
Height of Step	NS/SmS/MS (mm)	NS/SmS/MS (mm)
0	1582	-
150	1589	75
250	1602	125
300	1610	150
350	1620	175
400	1632	200

NS = NEETASCREEN®, SmS = SMARTASCREEN®, MS = MINISCREEN®



Measure the fall on the rail. This will allow you to position the top rail parallel and also to correctly cut the infill sheets.



Measure the amount to be cut and mark the sheet. Ensure you measure edge to edge, not rib to rib.

# 11.0 INSTALLING 2 OR 3 INFILL SHEETS PER PANEL FENCES

Installing the infill sheets is where the art is in fencing. It requires getting a few things to line up all at the same time. It's preferable to treat this as a one person job. Two people get in each other's way.

The following steps assume a standard fence style, however the steps are similarly applied to a 'PLUS' fence option. For the installation of the lattice for a 'PLUS Option' style. (Section 14).

Start at the high side. Insert the first sheet flush into the bottom rail, usually about 200mm out from the post. Lift the top rail and slowly slide the sheet into the top rail. Using your knee near the bottom of the sheet and your hand near the top, slowly ease the first sheet along the rails until they contact the post. Remember to move the sheet square or it might kick out of one of the rails.

When the second infill sheet is placed, make sure you place the sheet to allow for the overlap (Figure 13.2). At this stage some minor adjustments may be necessary to get the lap to sit correctly or to fit the sheet into the rail. Gently bump the fence sheet into position as required.

The third sheet is the most difficult, only because there are a few things to get right. Place the bottom of the sheet into the rail, ensuring there is overlap to the second sheet.

It is usually necessary to gently bump, and push this final sheet into position. Roll the top rail away from you and this will assist feeding the top of the sheet into the rail channel. Get the side facing away from you in the bottom rail and then you can push the ridges of the side facing towards you into position with both the rail and the post. Once the sheet is in position, gently tap the top rail down onto the sheets using the heel of your gloved hand.

Do not screw off the top rail until you have 'fine-tuned' the rails by standing back and looking at the whole of the fence. This allows you to make minor adjustments to get the rails aligned.



*Lift top rail and place 1st sheet into bottom rail. Slide to end position.*



*Lifting top rail helps ease 1st sheet into end position.*



*Place 2nd sheet into bottom rail, ensuring there is sufficient overlap.*



*Position 3rd sheet. Gentle force can be used.*



*Lift top rail and rotate until infill sheet slides into rail. Tap top rail down into position.*

## 12.0 INSTALLING 4 INFILL SHEETS PER PANEL FENCES

Installing the infill sheets is where the art is in fencing. It requires getting a few things to line up all at the same time. It's preferable to treat this as a one person job. Two people can get in each other's way.

Start at the high side. Insert the first sheet flush into the bottom rail, usually about 200mm out from the post. Screw one end of the top rail to the post with a single screw. Lift the top rail and slowly slide the sheet into the top rail. Using your knee near the bottom of the sheet and your hand near the top, slowly ease the first sheet along the rails until they contact the post. Remember to move the sheet square or it might kick out of one of the rails.

When the second infill sheet is placed, make sure you place the sheet to allow for the overlap (Figure 13.2). At this stage some minor adjustments may be necessary to get the lap to sit correctly or to fit the sheet into the rail. Gently bump the fence sheet into position as required.

The 3rd sheet is installed in the same way as the second sheet.

The final sheet is the more difficult, only because there are a few things to get right. Place the bottom of the sheet into the rail, ensuring there is overlap to the third sheet.

It is usually necessary to gently bump, and push this final sheet into position. Roll the top rail away from you and this will assist feeding the top of the sheet into the rail channel. Get the ribs facing away from you in the bottom rail and then you can push the ridges of the side facing towards you into position with both the rail and the post. Once the sheet is in position, gently tap the top rail down onto the sheets using the heel of your gloved hand.

Do not 'screw off' the top rail until you have fine-tuned the rails by standing back and looking at the whole of the fence. This allows you to make minor adjustments to get the rails aligned.



*Lift top rail and place 1st sheet into bottom rail. Slide to end position.*



*Lifting top rail helps ease 1st sheet into end position.*



*Place 2nd & 3rd sheets into bottom rail, ensuring there is sufficient overlap.*



*Position 4th sheet. Gentle force can be used.*



*Lift top rail and rotate until all infill sheets slide into rail. Tap top rail down but do not fasten into position yet.*



# 13.0 FINISHING OFF THE FENCE INSTALLATION

## ALIGN AND FINE TUNE RAILS BEFORE SCREWING THEM INTO POSITION

Do not screw off the rail yet.

Ensuring the rails are aligned, and the sheets are neat vastly improves the appearance of your fence.

Once you have installed all the bays, stand back from the fence and have a look at the fence as a whole.

Make sure the lines on your sheets run parallel to your posts. Make sure the joint of the overlap looks flush, without a big gap. Adjust where required.

Once you have made these adjustments, screw the rails into position. Mid rail screws are required top and bottom on NS4 fences and FS4 fences. (4 infill sheets per panel fences).

Remember to wipe off the fence to remove any swarf from the installation.



*Screw off top rail and make it as close to parallel with the bottom rail as possible. Stand back and look at your work as you go along.*

## FIXING THE INFILL SHEETS

Four infill sheet panel fences

The four infill sheet panel fence (NEETASCREEN® and SMARTASCREEN®) requires added fasteners through the top and bottom rails at the mid-point of the panel.

At the top rail a screw should pass through the rail from one side into the infill sheet (Figure 13.1). The screw should pass through the crest of the lap to stitch both lapping infill sheets (see Figure 13.2 for the laps), thus the screw passes through two thicknesses of infill sheet.

At the bottom rail one or more screws are required as detailed below;

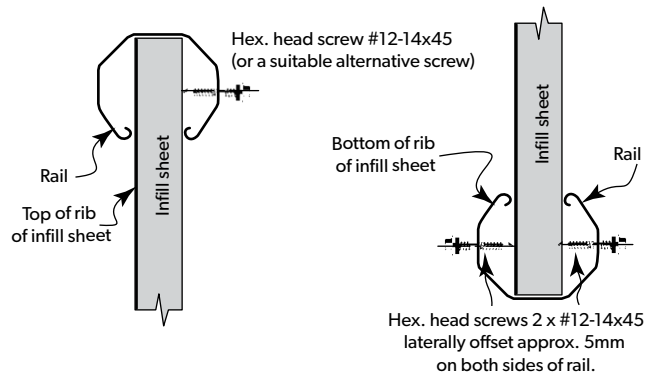
- For the NEETASCREEN® and SMARTASCREEN® fence panels - a screw should pass through the bottom rail from both sides into the infill sheet. One screw through the lap as described for the top rail, and one screw from the other side (offset from the lap fixing) into a single thickness of infill sheet (Figure 13.1).

## FIXING THE CENTRE RAIL FOR MINISCREEN® FENCES

Only the MINISCREEN® fence style requires a centre rail. For MINISCREEN® fences, fasten centre rails halfway up the infill sheets. Use at least seven (7) Ripple-type screws through the infill sheets into the centre rail. One screw should pass through the laps (Figure 13.2).

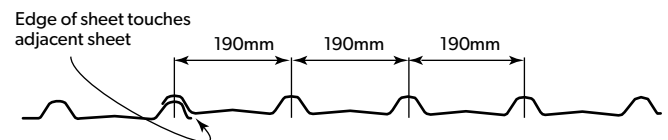
**FIGURE 13.1:**

Fixing infill sheet to rail on a four sheet/panel fence.



**FIGURE 13.2:**

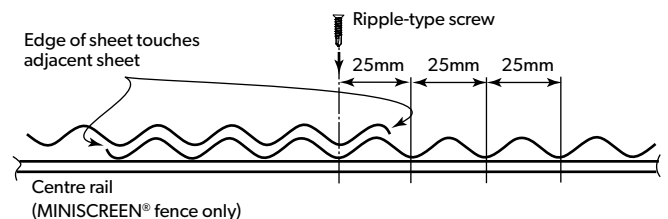
Sheet overlaps.



Minimum standard lap is as shown. Panel widths can be reduced in 190mm increments. NEETASCREEN® style.



Minimum standard lap is as shown. Panel widths can be reduced in 128mm increments. SMARTASCREEN® style



Minimum standard lap is as shown. Panel widths can be reduced in 25mm increments. MINISCREEN® style.

Dimensions are rounded to nearest mm.

# 14.0 INSTALLING 'PLUS OPTION'

## INSERTING THE LATTICE OR SLATS

Engage a top rail onto the top of a lattice or slats (Figure 14.2 for correct orientation).

Lower the rail and lattice or slats onto the top of a fence panel, engaging the ends of the rail with the posts (Figure 14.1).

Fix with three screws (#10-16x16) along the bottom flange of the lattice or slats to the top rail of the fence panel. (Figure 13.2) Protect the paintwork with a piece of cardboard between the drill body and the lattice.

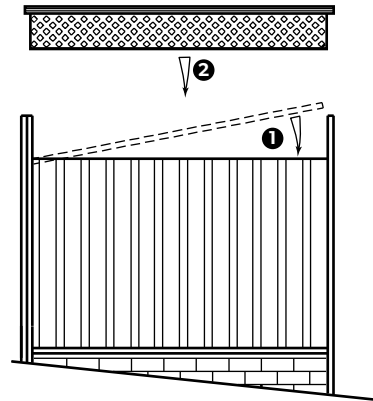
Fix the top rail to the lattice or slats with three screws (Figure 14.2).

Fasten the top rail to the posts with one hex. head screw (#10-16x16) on both sides of each post.

A component (edge cover strips used for gates) is available to cover edges of the lattice or slats if it is trimmed in length or use flashing/trim as described in gates.

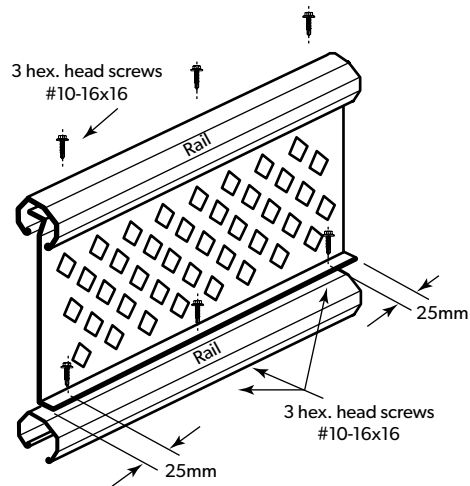
**FIGURE 14.1:**

1. Rail installation at top of infill sheets.
2. Installation of lattice.



**FIGURE 14.2:**

Fastening of 'PLUS Option'.  
(Lattice with NEETASCREEN® rails shown).



# 15.0 TAPERING ENDS OF FENCES

At the end of a fence run, where the fence doesn't form a corner (sometimes called a free end), the panels experience increased wind loadings—particularly where your fence extends beyond the alignment of your house.

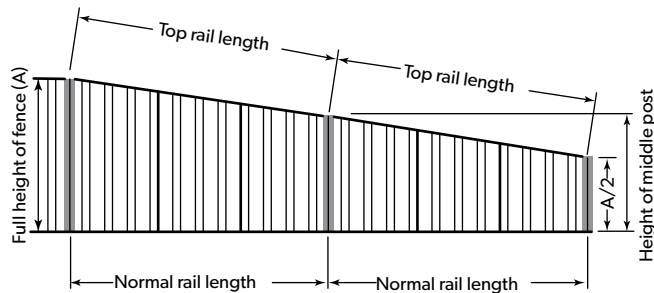
Tapering of 1500mm high fences is not mandatory in Terrain Category 3 of Wind Region B and all of Wind Region A. In all other cases your fence must be tapered in height over the last two panels (Figure 15.1).

Cut the top of the infill sheets in a manner similar to that shown for a raked fence (Figure 10.1).

A rail of 3300mm is available for this purpose.

**FIGURE 15.1:**

Tapering ends of fences.



**TABLE 15.1:**

Tapering ends of fences.

**4 Infill Sheets Per Panel**

	Fence Style	Half Fence Height	Height of Middle Post	Normal Rail Length	Top Rail Length
1500	NEETASCREEN®	750	1125	3100	3122
	SMARTASCREEN®	750	1125	3100	3122
1800	NEETASCREEN®	900	1350	3100	3132
	SMARTASCREEN®	900	1350	3100	3132
2100	NEETASCREEN®	1050	1575	3100	3144
	SMARTASCREEN®	1050	1575	3100	3144

**3 Infill Sheets Per Panel**

	Fence Style	Half Fence Height	Height of Middle Post	Normal Rail Length	Top Rail Length
1500	NEETASCREEN®	750	1125	2350	2380
	SMARTASCREEN®	750	1125	2350	2380
	MINISCREEN®	750	1125	2350	2380
1800	NEETASCREEN®	900	1350	2350	2393
	SMARTASCREEN®	900	1350	2350	2393
	MINISCREEN®	900	1350	2350	2393
2100	NEETASCREEN®	1050	1575	2350	2408
	SMARTASCREEN®	1050	1575	2350	2408
	MINISCREEN®	1050	1575	2350	2408

**2 Infill Sheets Per Panel**

	Fence Style	Half Fence Height	Height of Middle Post	Normal Rail Length	Top Rail Length
1500	NEETASCREEN®	750	1125	1582	1626
	SMARTASCREEN®	750	1125	1582	1626
	MINISCREEN®	750	1125	1582	1626
1800	NEETASCREEN®	900	1350	1582	1645
	SMARTASCREEN®	900	1350	1582	1645
	MINISCREEN®	900	1350	1582	1645
2100	NEETASCREEN®	1050	1575	1582	1667
	SMARTASCREEN®	1050	1575	1582	1667
	MINISCREEN®	1050	1575	1582	1667

# 16.0 INSTALLING INFILL STRIPS AND POST CAPS

## POST COVER STRIPS

Cover strips are used to complete the open side of two standard LYSAGHT® posts screwed back-to-back (Figure 16.1).

Cut the strips to an appropriate length and slide vertically in place. Some posts require a strip for the full length of the post. Short pieces are needed on stepped fences (Figure 16.1).

## POST CAPS

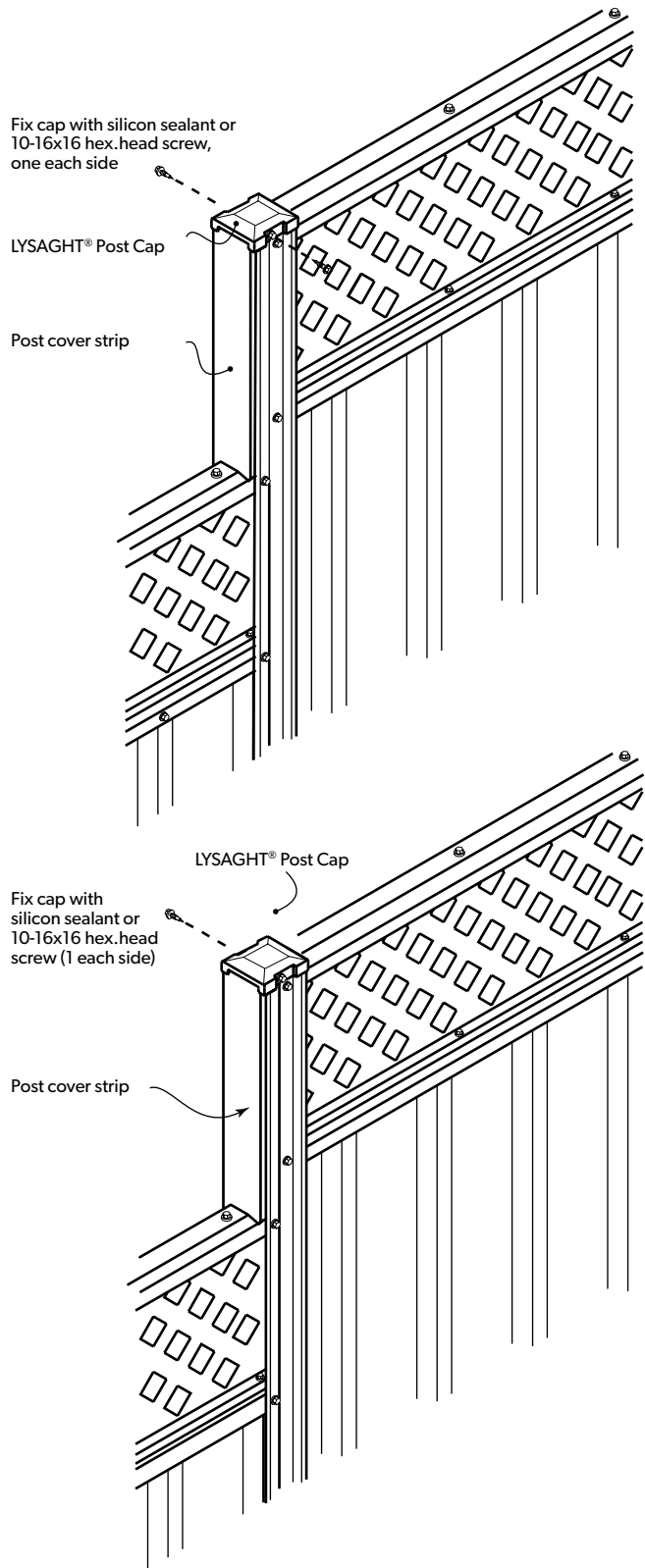
All post caps must be positively secured to your fence with either neutral cure silicone sealant or hex. head screws (Figure 16.1).

For a single standard post, it is easy to cut the LYSAGHT® post cap in half in the groove moulded into the underside — trim the edges straight. (For more information, refer to Section 25).



**FIGURE 16.1:**

Installation of post caps and post infill strips.



# 17.0 GATE SIZES, GATE COMBINATIONS AND GATE KITS

There are a large range of gate sizes, gate combinations and gate accessories available, check with your LYSAGHT® fencing supplier for availability in your area. There are a range of kits available to simplify the selection of the components that make up the gate system options.

Our gate systems are designed to perfectly complement our fences. Detailed instructions for the assembly of the gate system are given, together with a set of pictorial instructions. Please refer to both to help you visualise the process.

## TOOLS REQUIRED

Refer to Section 3 for the range of tools required for the fence assembly and installation. With particular application to the gate assembly and installation the tools required are; screw gun, tin snips, safety gloves plus glasses, marker and tape measure; fine toothed metal file and square.

## GATE WIDTHS, GATE POST SPACING AND FOOTINGS

For gate widths and post clearances see Table 17.2 below.

### SINGLE GATE KITS

For single gates, posts clearance must be the width of the gate, plus 20mm (i.e. 10mm post/gate clearance on either side).

### DOUBLE GATE KITS

For double gates, posts clearance must be the width of the double gates plus 30mm (i.e. 10mm post/gate clearance on either side and 10mm gate/gate clearance).

## GATE KITS

Gate kits are available for a single gate of standard width gates and extra wide gates. Combinations of these gates can then be made to make up various combinations of double gate systems. The contents of all gate kits generally consist of the following (Table 17.1):

## GATE ACCESSORY KITS

Gate accessory kits are available which include hinges, latch/lock set, handle, drop bolt, stile caps and appropriate fasteners.

Gate accessories kits are available in an economy, standard and premium packages. Contact your nearest Lysaght office for details.



**TABLE 17.1:**




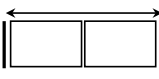
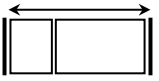
Contents of a Gate Kit	Quantity
Stiles	2
Bottom Rail *	1
Top Rail *	1
Lower Top Rail * #	1
Lower Top Rail Clip (Lattice Gate Clip) #	2
Lattice #	1
Centre Rail ^	1
Centre Rail Clip ^	2

NOTES: \*Rails are identical \*PLUS version only ^MINISCREEN® only Fasteners (#10-16x16 Ripple type) included in kit. Components that must be ordered separately include: Infill sheets, gate posts, gate accessories, all other fasteners, edge cover strips for infills (if required), trims for lattice (if required).

**TABLE 17.2:**

Gate configuration options.

Gate Dimensions (mm)	Fence System	Fence System		
		NEETASCREEN®	SMARTASCREEN®	MINISCREEN®
Standard Width Gate (Note 2) 	Gate width (Note 3)	885	885	910
	Lattice length	815	815	815
	Rail length	815	815	840
Extra Wide Gate (Note 2) 	Gate width (Note 3)	1645	1645	1655
	Lattice length	1575	1575	1575
	Rail length	1575	1575	1585
			Note 6	Note 5
			Note 6	Note 5

Distance Between Posts (mm) (Note 4)	Fence System	Fence System		
		NEETASCREEN®	SMARTASCREEN®	MINISCREEN®
Single Gate 	Standard Width Gate	905	905	930
	Extra Wide Gate 	1665	1665	1675
Double Gate Combinations 	2x Standard Width Gate	1800	1800	1850
	2x Extra Wide Gate 	3320	3320	3340
	1x Standard Width Gate 1x Extra Wide Gate 	2560	2560	2595

NOTE: 1. The above dimensions are for the standard fence system and the PLUS fence system  
2. Standard width gate = 1 infill sheet; Extra wide gate = 2 infill sheets  
3. Overall width of gate

4. Face-to-face internal dimension between posts  
5. Lattice may require a trim  
6. Edge Cover Strip for infill may be required

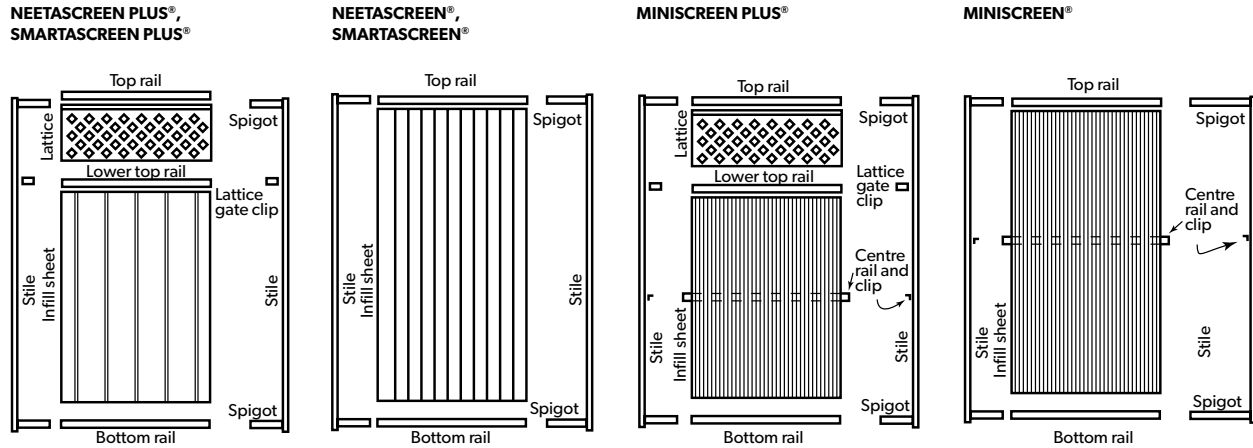
# 18.0 COMPONENTS FOR GATE ASSEMBLY AND INSTALLATION

Detailed below is the componentry required for assembly and installation of your new fence gate. Ensure you determine the best option and required components from the following pages prior to

placing your order. Please check with your local LYSAGHT® fencing supplier for availability of components in your area.

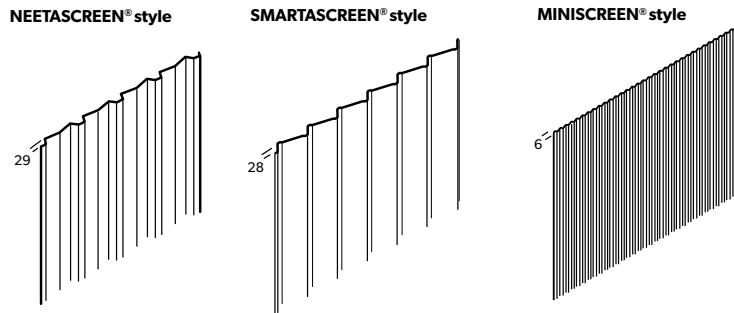
**FIGURE 18.1:**

Gate components.



## Infill Sheet Styles

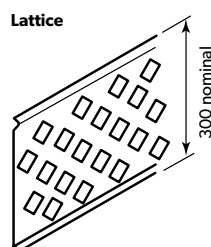
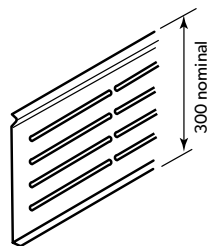
Standard lengths: 1490, 1790 & 2090mm  
Standard lengths for 'PLUS': 1190, 1490 & 1790mm



## 'PLUS' Options

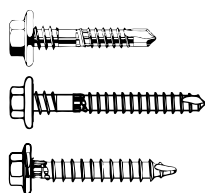
NEETASCREEN PLUS®  
SMARTASCREEN PLUS®  
MINISCREEN PLUS®

**Slats**  
(Available NSW, VIC and WA only)



## Fasteners

(All gate types) Self-drilling, self tapping hex. washer-head screws 10-16x16



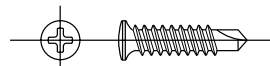
(Extra wide gates only) Self-drilling, self tapping, hex. head screw 12-14 x 45 or RoofZips M6-11x50 or AutoTek's M5.5-14x50

**Ripple Screws**  
(MINISCREEN® range only)

RippleZip® screw or M4.8-16x25

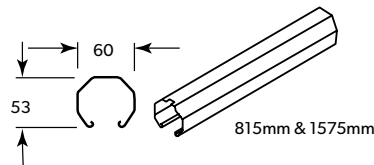


Ripple Tek® screw 10-16x20

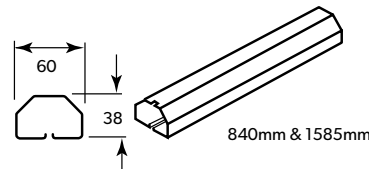


## Rails

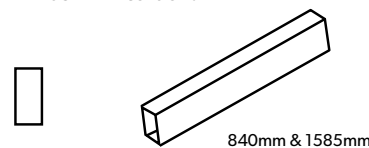
**NEETASCREEN®, SMARTASCREEN® Universal Rail**



**MINISCREEN® Universal Rail**

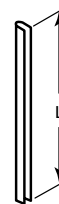


**MINISCREEN® Centre Rail**



## Edge Cover Strip

(SMARTASCREEN® only)  
Standard lengths:  
L= 1160, 1460, 1700, 2060



# 19.0 INSTALLATION OF GATE POSTS AND GATE

## FOR GATE ASSEMBLY, SEE FOLLOWING SECTIONS 20-21

1. Select post size - 60x60mm for Standard Width Gate, 65x65mm for Extra Width Gate. Footings for gate posts must be prepared and constructed in accordance with the fence installation guidelines (Section 11).
2. Measure the gap where you are going to position the gate to know where to set the posts. Measurements should allow room for the gate to swing, and for space between stiles & posts. (Recommended allowances are given on Table 17.2 of this manual.)
3. Set the level at the height required to swing clear of the ground. Use a measuring tape or the level to show where gate aligns with the post and mark this position (using a compatible marker, not a lead pencil).
4. Set the second post so the post tops align and check it is plumb. Measure the position of gate height and mark on post.
5. Use the level to double check plumb and gate positioning. Remember that a level gate swings free and easy.
6. Fit the hinges to the selected stile of the gate, using 4 screws per hinge. Install the hinges on the wide face of the stile (not on the narrow face) (Figure 19.1). To avoid rust stains, it is important to brush and shake out drill swarf from the gate and rails.
7. Hang the gate. Attach the latch, handle and drop bolt as required.
8. Clean off any marks, hose down the completed gate, and fit the post caps to the stiles.



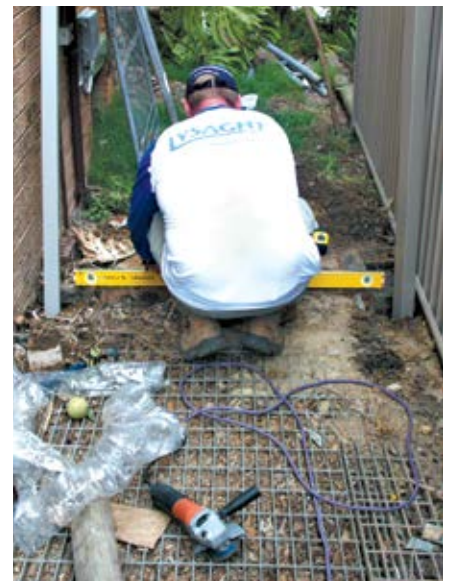
Step 1/2



Step 3

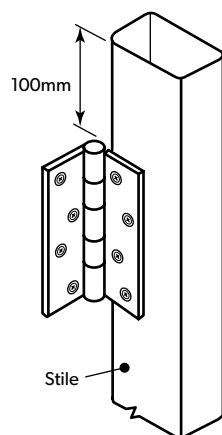


Step 4



Step 5

**FIGURE 19.1:**  
Fixing of hinges.



Step 6



Step 7/8

# 20.0 GATE ASSEMBLY - PREPARATION STEPS (NEETASCREEN® & SMARTASCREEN® GATES)

## INFILL SHEET

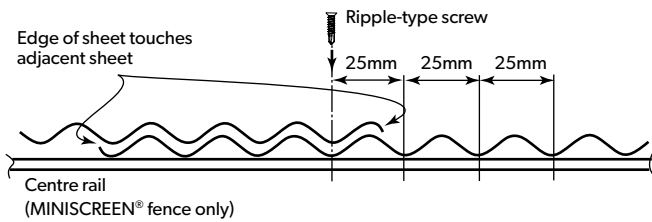
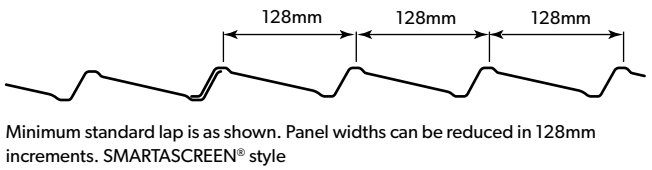
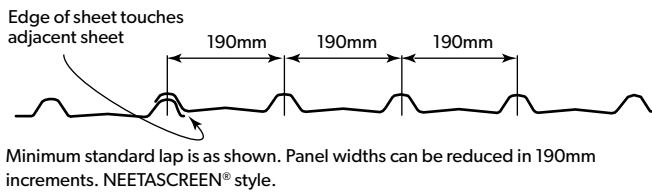
1. Lay sheet(s) on a horizontal surface. Use some soft material to protect the COLORBOND® steel finish.
2. For extra-wide gates: overlap sheets to the desired width (Figure 20.1). Join the two sheets with hex. head screws (#10-16x16), through the overlaps, at both top and bottom edges (Figure 20.2).
3. Using tin snips, notch the four corners. The top and bottom notches are different (Figure 20.3).
4. If required, fit edge cover strip to one side of the infill sheet for SMARTASCREEN® gates (Figure 20.4).

## GATE LATTICE OR SLATS

5. If required, trim the lattice to fit the width of your gate. Equally trim both ends to retain a balanced effect (Figure 20.6). Notch the top leg of the lattice/slats on both ends (Figure 20.5).

**FIGURE 20.1:**

Sheet overlaps for extra wide gates.

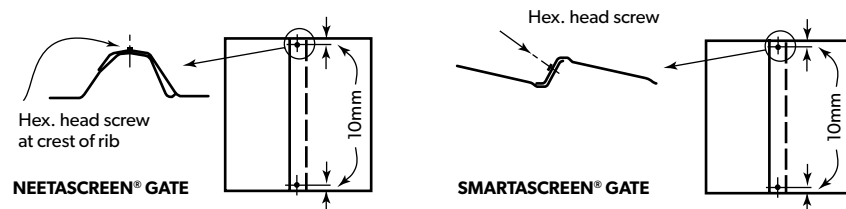


Minimum standard lap is as shown. Panel widths can be reduced in 25mm increments. MINISCREEN® style.

Dimensions are rounded to nearest mm.

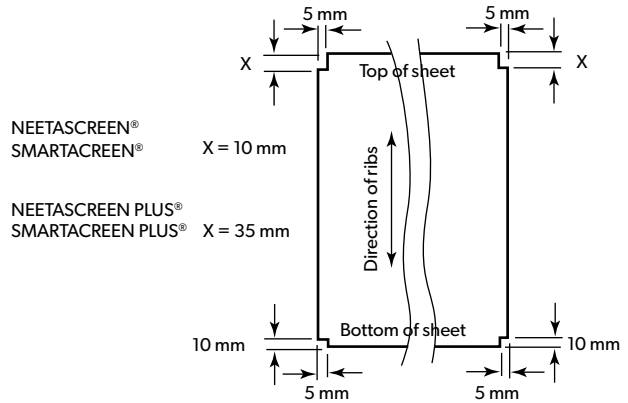
**FIGURE 20.2:**

Joining of sheets for extra wide gates.



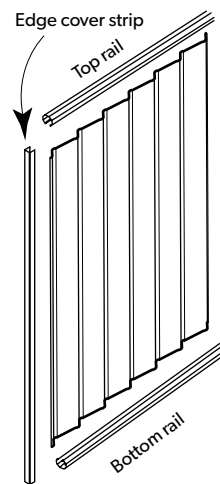
**FIGURE 20.3:**

Notching of corners.



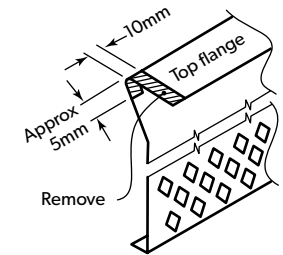
**FIGURE 20.4:**

Fit Edge Cover Strip (SMARTASCREEN®).



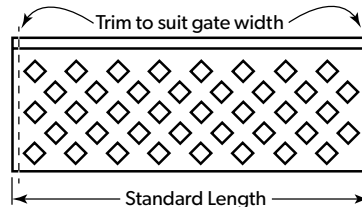
**FIGURE 20.5:**

Notch at top of lattice.



**FIGURE 20.6:**

Length of lattice.



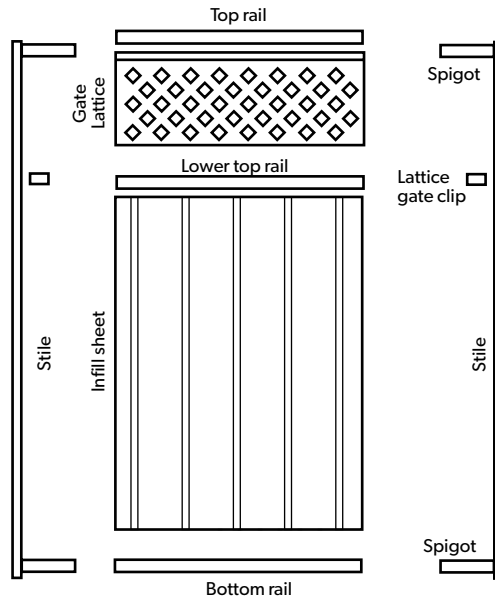


# 21.0 GATE ASSEMBLY - (NEETASCREEN® & SMARTASCREEN® GATES)

1. Complete the preparation steps if they are not already done.
2. Lay out all the components (Figure 21.1) on some soft material to protect the COLORBOND® steel finish.
3. For gates with no lattice, go to step 5.
4. For 'PLUS Option' (with lattice/slats) gate: Mark the position of the two lattice gate clips. Fasten the clips to the stiles using two hex. head screws (#10-16x16) for each (Figure 21.2).
5. Lay the infill sheet(s) on a horizontal surface. Slide the top rail (lower top rail if lattice is used) onto the top of a sheet(s). A rubber mallet or piece of timber can help.
6. Fit the bottom rail similarly.
7. Insert the spigots of the stiles into the top and bottom rails. If a lattice is used, ensure that the lower top rail fits neatly onto the lattice gate clips. (Figures 21.1, 21.3). Even up the sheets by bumping the ribs with the palm of your hand.
8. Hold both stiles firmly in place and drive one hex. head screw (#10-16x16) in each of the four corners, 20mm from the inside edge of the stile (Figure 21.3).
9. Check squareness by measuring the gate's diagonals. Drive a second hex. head screw (see below) in each of the four corners, at first inner rib (non side-lap rib) of infill sheet from the stile for NEETASCREEN® and SMARTASCREEN® (Figure 20.3).
  - For standard width gate (with or without 'PLUS Option') use #10-16x16 screws.
  - For extra wide gate (without 'PLUS Option') use #12-14x45\* screws.
  - For extra wide gate (with 'PLUS Option') at top rail use #10-16x16 screws and at bottom rail use #12-14x45\* screws.
10. For extra wide gate with 'PLUS Option' additional screws are

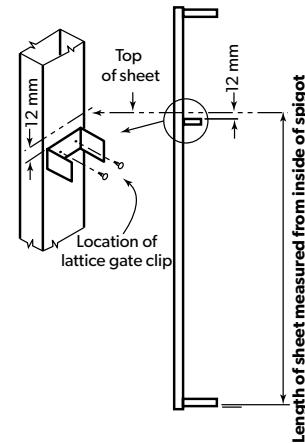
**FIGURE 21.1:**

Initial layout of parts.



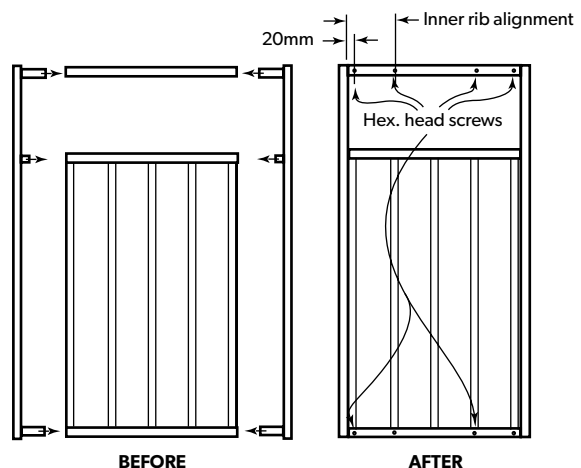
**FIGURE 21.2:**

Positioning of lattice clips for gates with lattice or slats.



**FIGURE 21.3:**

Assembly of stiles (NEETASCREEN PLUS® shown).

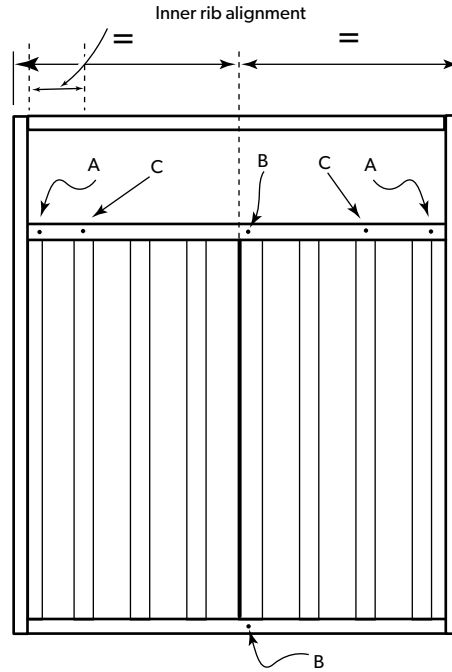


required (Figure 21.4):

- Lower top rail at corners passing through the lattice clip at Position A #10-16x16.
  - Lower top rail at corners passing through the inner rib alignment at Position B #12-14x45\*.
  - Lower top rail & bottom rail passing through the lapped rib at Position C #12-14x45\*.
11. Turn the gate over and drive two #10-16x16 hex. head screws in each corner, placed in alignment to those in Steps 8 and 9. For gate (standard width and extra wide) with 'PLUS Option', drive an additional #10-16x16 screw into the two corners of the lower top rail passing through the lattice or slats clip in alignment with Position A (Figure 21.4).
  12. If your gate includes a 'PLUS Option' (lattice or slats), insert it into the top rail. Swing the bottom of the lattice/slats in and secure it to the lower top rail using 3 hex. head screws #10-16x16 for standard width gates, or 3 for extra wide gates. Secure it also to the top rail: 2 screws for standard width gates, and 3 screws for extra wide gates (Figure 21.5).

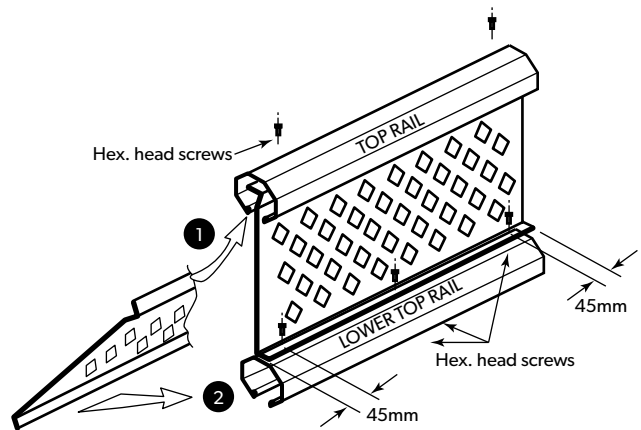
**FIGURE 21.4:**

Location of added fasteners for extra wide 'PLUS' gates.



**FIGURE 21.5:**

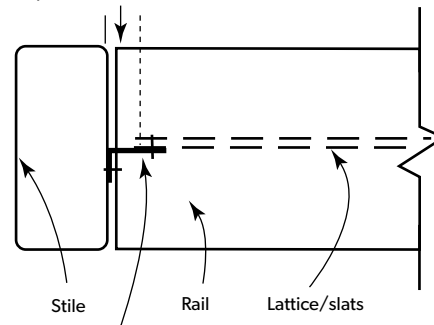
Fixing of 'PLUS Option' (standard width gate, lattice shown).



**FIGURE 21.6:**

Plan detail - Stile to lattice trim.

Gap to be covered at both ends, if desirable



Trim/flashing to match the colour of the lattice/slats. Fix with rivets top and bottom to lattice/slats and stile.

Standard universal rail shown, however the installation process is the same for MINISCREEN® rail.



# 22.0 GATE ASSEMBLY - PREPARATION STEPS (MINISCREEN® GATES)

## INFILL SHEET

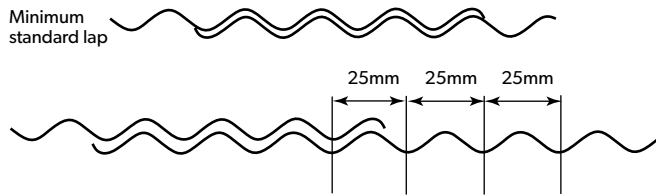
1. Lay sheet(s) on a horizontal surface. Use some soft material to protect the COLORBOND® steel painted finish.
2. For extra-wide gates: overlap sheets to the desired width (Figure 23.1). Join the two sheets with hex. head screws #10-16x16 through the overlaps, at both top and bottom edges (Figure 23.2).
3. Using tin snips, notch the four corners. The top and bottom notches are different (Figure 23.3). Lower top rail and gate lattice.
4. If required, trim the lattice to fit the width of your gate. Equally trim both ends to retain a balanced effect (Figure 23.5).
5. Notch the top leg of the lattice on both ends (Figure 23.4).
6. Remove the internal lips of the lower top rail for 5mm at both ends (Figure 23.6).

## GENERAL

7. File all cut edges to remove burrs.

**FIGURE 22.1:**

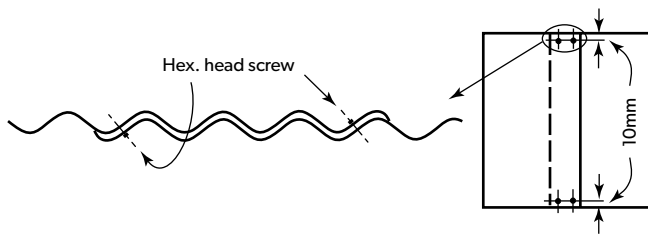
Sheet overlaps for extra wide gates.



Gate widths can be reduced in 25mm increments

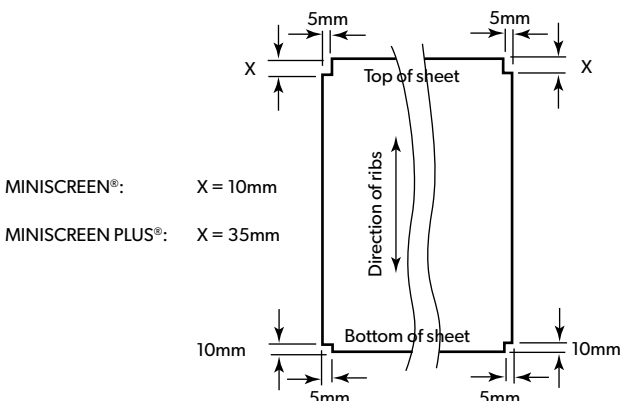
**FIGURE 22.2:**

Joining of sheets for extra wide gates.



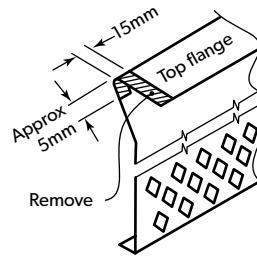
**FIGURE 22.3:**

Notching of corners.



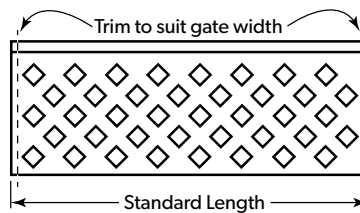
**FIGURE 22.4 :**

Notch at top of lattice.



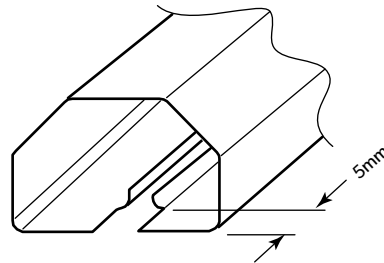
**FIGURE 22.5:**

Length of lattice.



**FIGURE 22.6:**

Notching of lower top rail.



## 23.0 GATE ASSEMBLY (MINISCREEN® GATES)

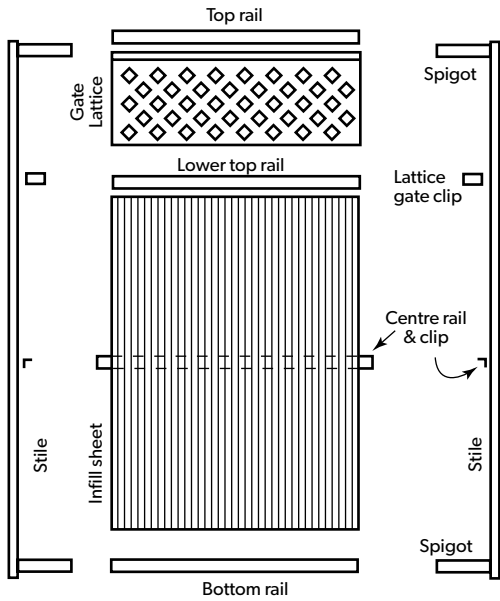
1. Complete the preparation steps if they are not already done.
2. Lay out all the components (Figure 23.1) on some soft material to protect the COLORBOND® steel finish.
3. If your gate includes a 'PLUS Option' (lattice or slats), mark the position of the two lattice gate clips. Fasten the clips to the stiles using two hex. head screws #10-16x16 for each (Figure 23.3).
4. Mark the position of the two centre rail clips, with the inner edge of the clip 2mm from the centreline of the stile, and fasten them to the stiles using a hex. head screw #10-16x16 for each (Figure 23.3).
5. Lay the infill sheet(s) on a horizontal surface. Slide the top rail (lower top rail if 'PLUS Option' is used) onto the top of a sheet(s). A rubber mallet or piece of timber can help.
6. Fit the bottom rail similarly.
7. Insert the spigots of both stiles into the top and bottom rails and locate the centre rail on its clips. If a lattice is used, ensure that the lower top rail fits neatly onto the lattice gate clips (Figure 23.2). Even up the sheets by bumping the ribs with the palm of your hand.
8. Hold both stiles firmly in place and drive one hex. head screw #10-16x16 in each of the four corners, 20mm from the inside edge of the stile (Figure 23.2).
9. Check squareness by measuring the gate's diagonals. Drive a second hex. head screw (#10-16x16) in each of the four corners, 170mm from the stile (Figure 23.2).
10. For gate with 'PLUS Option', drive an additional #10-16x16 screw into the two corners of the lower top rail passing through the lattice clip in alignment with Position A (Figure 23.4).
11. Turn the gate over and drive a hex. head screw in each corner, placed similarly to those in Step 8.
12. Drive a second hex. head screw (see below) in each corner, placed similarly to those in Step 9.
  - For standard width gate (with or without lattice) use #10-16x16 screws.
  - For extra wide gate (without lattice) use #12-14x45\* screws.
  - For extra wide gate (with lattice) at top rail use #10-16x16 screws and at bottom rail use #12-14x45\* screws.
13. For extra wide gate with lattice additional screws are required (Figure 23.4).
  - Lower top rail at corners passing through the lattice clip at Position A - #10-16x16.
  - Lower top rail at corners passing through the inner rib alignment at Position C - #12-14x45\*.
  - Lower top rail & bottom rail passing through the lapped infill sheets at Position B - #12-14x45\*.
14. Fix the infill sheet(s) to the central rail with a minimum of 3 Ripple screws for standard width gate and 5 Ripple screws for extra wide gate. For the extra wide gate one screw must pass through the lap of the infill sheets.
15. If your gate includes a lattice, insert it into the top rail. Swing the bottom of the lattice in, and secure it to the lower top rail using 3 hex. head screws for standard width gates, or 3 for extra wide gates. Secure it also to the top rail: 2 screws for standard width gates, and 3 screws for extra width gates (Figure 23.5).
16. Ensure the lattice is centred. If desirable, the gaps on either side of the 'PLUS Option' can be filled with a suitably sized flashing (trim and fix with rivets top and bottom to lattice/slats and stile - Figure 23.6).

If the lattice/slats has been trimmed to suit the width of the gate, then a similar flashing/trim may be appropriate.

\*Or a suitable alternative.

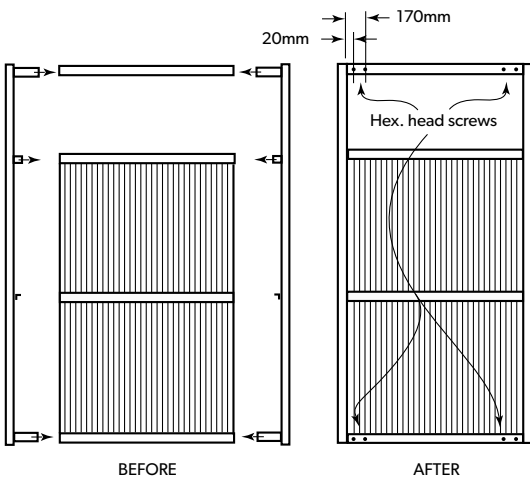
**FIGURE 23.1:**

Initial layout of parts (showing 'PLUS Option').



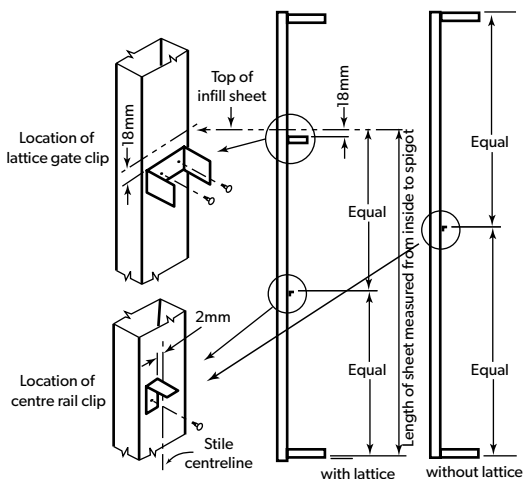
**FIGURE 23.2:**

Assembly of stiles (MINISCREEN PLUS® shown).

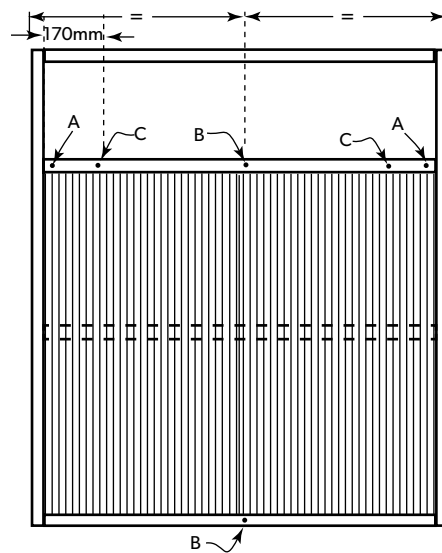


**FIGURE 23.3:**

Positioning of clips for gates.

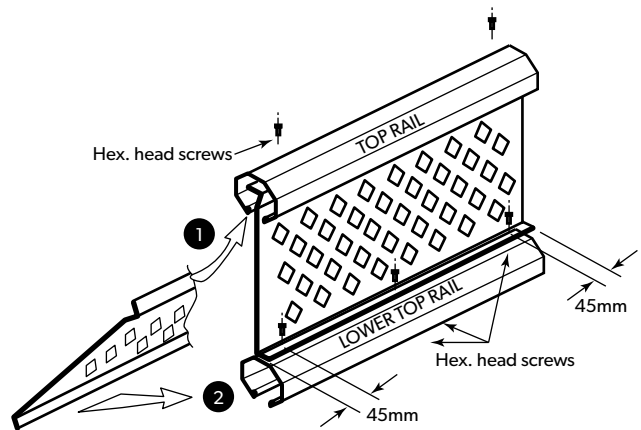


**FIGURE 23.4:**



**FIGURE 23.5:**

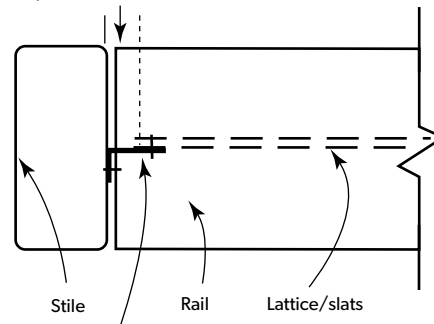
Fixing of lattice (standard width gate shown).



**FIGURE 23.6:**

Plan detail - Stile to lattice angle trim.

Gap to be covered at both ends, if desirable



Trim/flashing to match the colour of the lattice/slats. Fix with rivets top and bottom to lattice/slats and stile.

Standard universal rail shown, however the installation process is the same for MINISCREEN® rail.

# 24.0 ADDING A 'PLUS OPTION' TO AN EXISTING LYSAGHT® FENCE

## CONVERSION KIT COMPONENTS\*

### COMPONENT QUANTITY

Extension posts	2
Top rail	1
Lattice (or Slats)	1
Fasteners	16
* (per panel)	

### STEP 1

Remove existing screws from post and top rail junction of existing fence, as shown in Figure 24.1.

### STEP 2

Slide post extension down over top of existing post till cut out meets existing top rail. Fasten with 2 screws, as shown in Figure 24.2.

### STEP 3

Engage a top rail onto the top of a lattice or slats (Figure 24.4 for correct orientation).

Lower the rail and lattice onto the top of a fence panel, engaging the ends of the rail with the posts (Figure 24.3).

Fix with three hex. head screws along the bottom flange of the lattice or slats (Figure 24.4). Protect the paintwork with a piece of cardboard between the drill and the lattice.

Fix the top rail to the lattice or slats with three hex. head screws (Figure 24.4).

Fasten the top rail to the post extensions with one hex. head screw on both sides of each post.

### STEP 4

Place the post cap over top of post extension and top rail. They can be secured with one screw on either side of the post (Figure 24.5).

FIGURE 24.1:

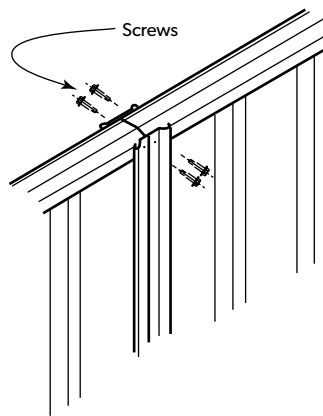


FIGURE 24.2:

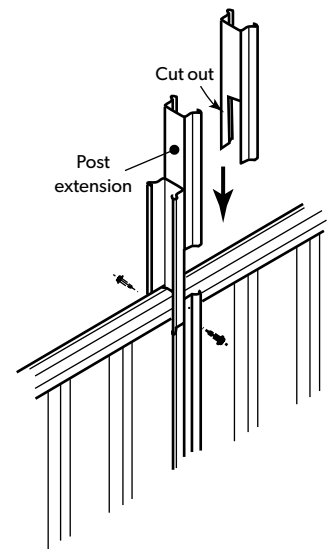


FIGURE 24.3:

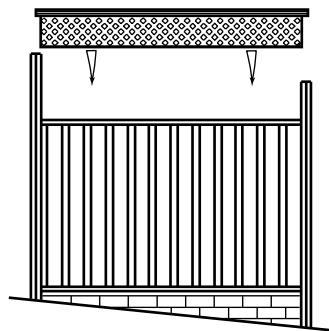


FIGURE 24.4:

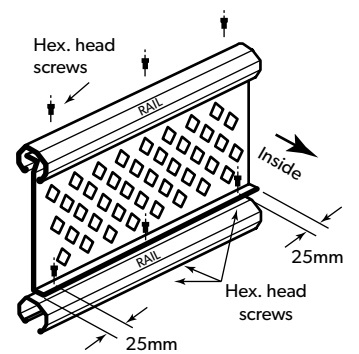
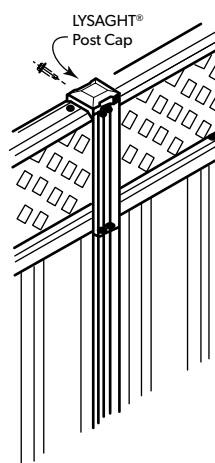


FIGURE 24.5:



Standard universal rail shown, however the installation process is the same for MINISCREEN® rail.

# 25.0 POST CAPS INSTALLATION

The range of plastic post caps provides a safety barrier by covering sharp edges on posts of all heights. They improve the look of your fence and in turn add value to your home. They are very easy to use and install. They push on easily over the outside of the top of the post and may be fitted during or after construction. To prevent accidental or intentional removal we recommend that they be screwed into position.

The benefits of using the plastic Post Cap include:

- Provides safety from cut or exposed edges.
- Colour matched to the COLORBOND® steel fencing colours.
- Inexpensive when compared to metal powder-coated caps.
- While sturdy and strong and flexible allowing for an easy fit

There is one type of post cap: the LYSAGHT® Post Cap.

## LYSAGHT® POST CAP

The LYSAGHT® Post Cap is suitable for the LYSAGHT® posts (C-Post) when using universal rails for all LYSAGHT® fences. It comes as a double cap suitable for back-to-back posts.

It has a cutting guide for easy on-site cutting for single post applications, such as a stepped fence or at the end of a run. Just nick either side of the post cap, bend back and slice along the fold with a sharp knife in the groove moulded into the underside. Alternatively cut with a hacksaw. Trim the edges straight. While cutting take care not to mark the exposed face of the cap. Place over the outside of the post for a firm and perfect fit.

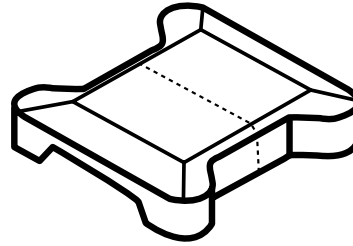
These post caps can be screwed in on the side into the posts or through the top into the rail, or secured with silicon sealant.

## OTHER POST CAPS

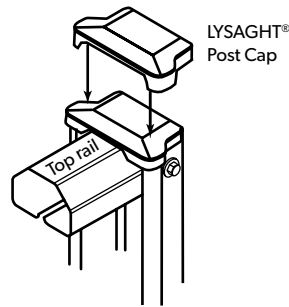
There are other plastic caps (black) in the LYSAGHT® range:

- For the tubular square posts, 60x60 and 65x65 black plastic caps.
- The gate accessory kits also come with stile caps (plugs) in the size 57x35mm.

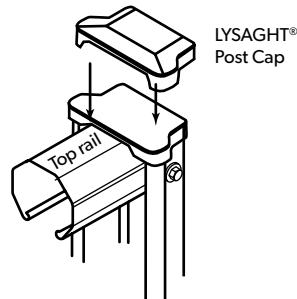
**FIGURE 25.1:**  
LYSAGHT® Post Cap.



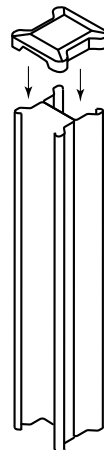
**FIGURE 25.2:**  
MINISCREEN® (and PLUS Option).



**FIGURE 25.3:**  
NEETASCREEN® (& PLUS) SMARTASCREEN® (& PLUS) using universal rail.



**FIGURE 25.4:**  
LYSAGHT® Post Cap.



## PRODUCT DESCRIPTIONS

- All descriptions, specifications, illustrations, drawings, data, dimensions, and weights contained in this publication and websites containing information from Lysaght are approximations only. They are intended by Lysaght to be a general description for information and identification purposes and do not create a sale by description. Lysaght reserves the right at any time to:

- (a) Supply goods with such minor modifications from its drawings and specifications as it sees fit, and
- b) Alter specifications shown in its publications and websites to reflect changes made after the date of publication.

## DISCLAIMER, WARRANTIES AND LIMITATION OF LIABILITY

- This publication is intended to be an aid for all trades and professionals involved with specifying and installing LYSAGHT® products and not be a substitute for professional judgement.
- Terms and conditions of sale are available at [lysaght.com/terms](https://lysaght.com/terms)
- Except to the extent to which liability may not lawfully be excluded or limited, BlueScope Steel Limited will not be under or incur any liability to you for any direct or indirect loss or damage (including, without limitation, consequential loss or damage such as loss of profit or anticipated profit, loss of use, damage to goodwill and loss due to delay) however caused (including, without limitation, breach of contract, negligence and/or breach of statute), which you may suffer or incur in connection with this publication.

## AUSTRALIAN STANDARDS

Australian Standard	Definition
AS/NZS 1170.2:2021	Structural design actions, Part 2: Wind actions

FOR DETAILED PRODUCT INFORMATION,  
MANUALS AND PROJECT CASE STUDIES VISIT:

[WWW.LYSAGHT.COM](https://www.lysaght.com)

COLORBOND®, LYSAGHT® and ® product names are registered trademarks of BlueScope Steel Limited and ™ product names are trademarks of BlueScope Steel Limited. © 2026 BlueScope Steel Limited. ABN 16 000 011 058. All rights reserved.

INSPIRATION TO BUILD BETTER

