

K-Clad Roof Panel Installation Guide

Multiple Panels Eaves to Ridge
150mm End Lap

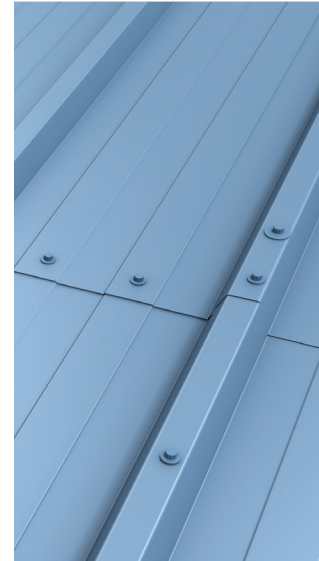

Factory Applied Weather Seal
(FAWS) to side laps only

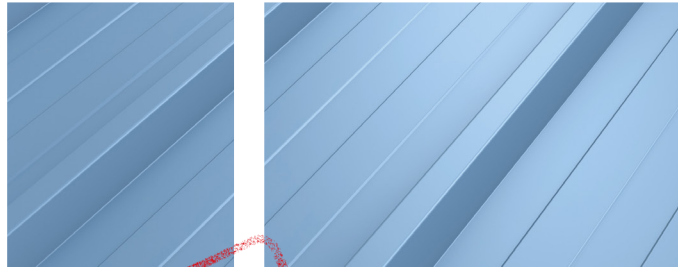
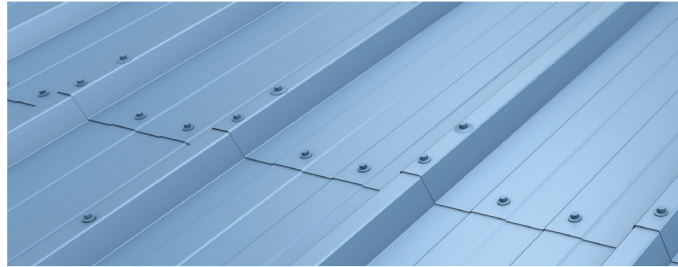

K-Clad Roof Panel

Multiple Panels Eaves to Ridge
150mm End Lap

Components

K-Clad Roof Panel



Profiled ridge filler (Code: 3RWFILL)



Primary / main fastener

(Carbon Steel)
(Not by Kingspan)

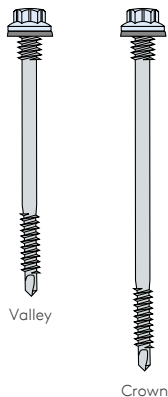

Secondary / stitching screws with washer

(Carbon Steel)
(Not by Kingspan)



Fire rated canister foam

(Not by Kingspan)



Neutral cure gun-grade sealant

(Not by Kingspan)



Butyl tape sealant

(Code: SEXT)



Cordless drill

(Not by Kingspan)



This installation guide should be read in conjunction with the 'project specific' design drawings and method statements.

Although this installation guide is deemed to be correct at the time of publication, Kingspan reserve the right to amend the information at any time in the future. Installation Guides are available for the full range of Kingspan Insulated Roof, Wall and Facade Systems.

K-Clad Roof Panel

Multiple Panels Eaves to Ridge
150mm End Lap

Notes

- Ensure steel work is suitable for panels and is within tolerance.
- The end lap purlin position is critical, check location and straightness.
- Number of fasteners must be calculated based on project spans and wind loads.
- Ensure panels are perpendicular to gutter.
- Ensure lower panel is bearing on to purlin by a minimum of 50mm.
- A Factory Applied Weather Seal (FAWS) is applied to all panel side laps.
- All sealants to suit project specification requirements.
- Protective film to be removed from external weather face of panel & internal liner, where applicable, prior to installation.
- Please contact Kingspan Technical Services Department for guidance
 - Internal air seals
 - High humidity & hygiene internal environments
 - Project specific advise
- Colour of sealants within this installation guide are for illustration purposes.
- Contact Kingspan Technical Services for project specific advice.
- Sheets can be turned up at the ridge.
- Penetrations larger than 300mm x 300mm must be framed out with structural steel.
- Clean swarf off panels immediately when created.
- Ensure panel joints are pulled tight to adjacent panels to close any gaps as works progress.
- This installation guide provides generic guidance on installation methods, however, should be read in conjunction with project specific specifications and construction details.
- Install fasteners with recommended screw gun speed selection for type of steel, use correct socket and drive bit, including depth - locating nose piece, unless fastener has feature to prevent overdriving, in line with fastener manufacturers.

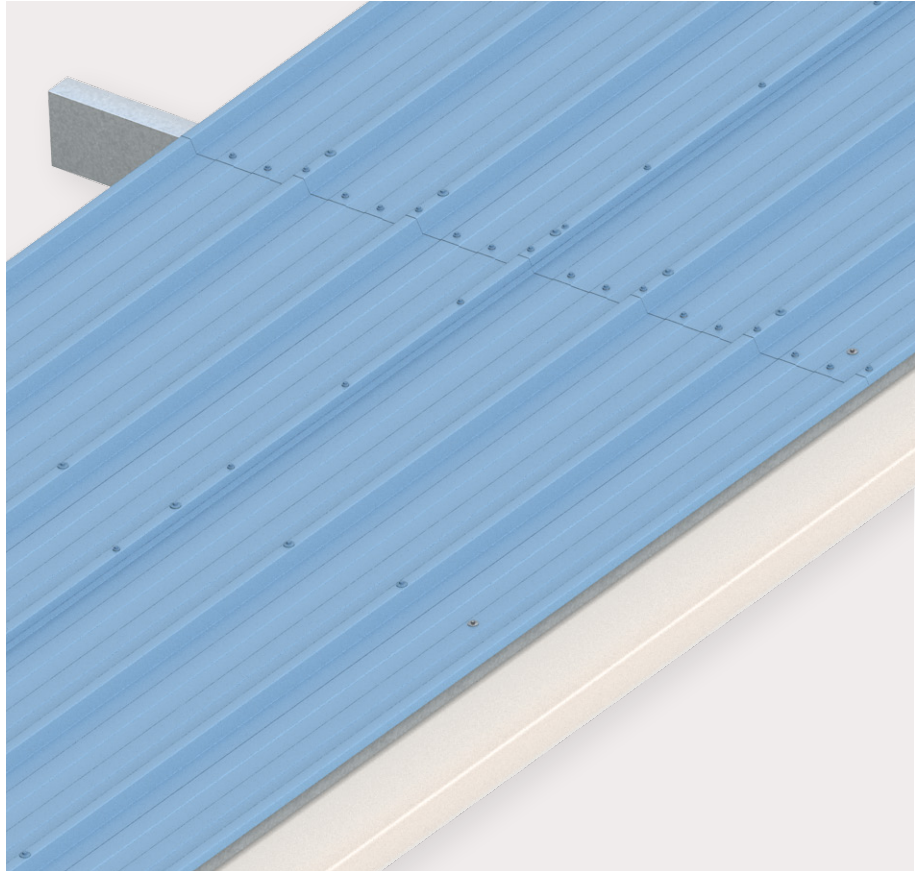

K-Clad Roof Panel

Multiple Panels Eaves to Ridge

150mm End Lap

Fastener Layouts

End / Side Lap

Side lap stitching screws (6.3mm \times 25mm long) with min. 8mm dia washers at 450mm centres (**maximum**). Colour to suit panel

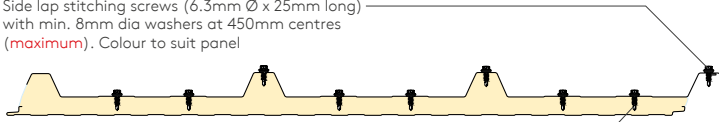

End lap stitching screws (6.3mm \times 25mm long) with min. 8mm dia washers 2 per valley and 1 at each crown, 35mm upslope from panel end. Colour to suit panel

Ridge

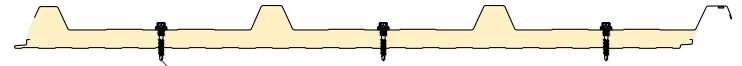

Self-drilling, self tapping primary fasteners with minimum 19mm \varnothing non-ferrous EPDM backed washer, 1 at each valley at each support

Standard Intermediate, Eaves & Side Lap



Self-drilling, self-tapping primary fasteners with minimum 19mm \varnothing non-ferrous EPDM backed washer, 1 at each crown at each support, 135 mm upslope from panel end. Colour to suit panel

Verge



Self-drilling, self tapping primary fasteners with minimum 19mm dia non ferrous EPDM backed washer. 1 in the valley, 2 in the crown at each support

**Note: Minimum number of fasteners as illustrated.
Number of fasteners must be calculated on the project specific spans and wind loads.**

K-Clad Roof Panel

Multiple Panels Eaves to Ridge

150mm End Lap

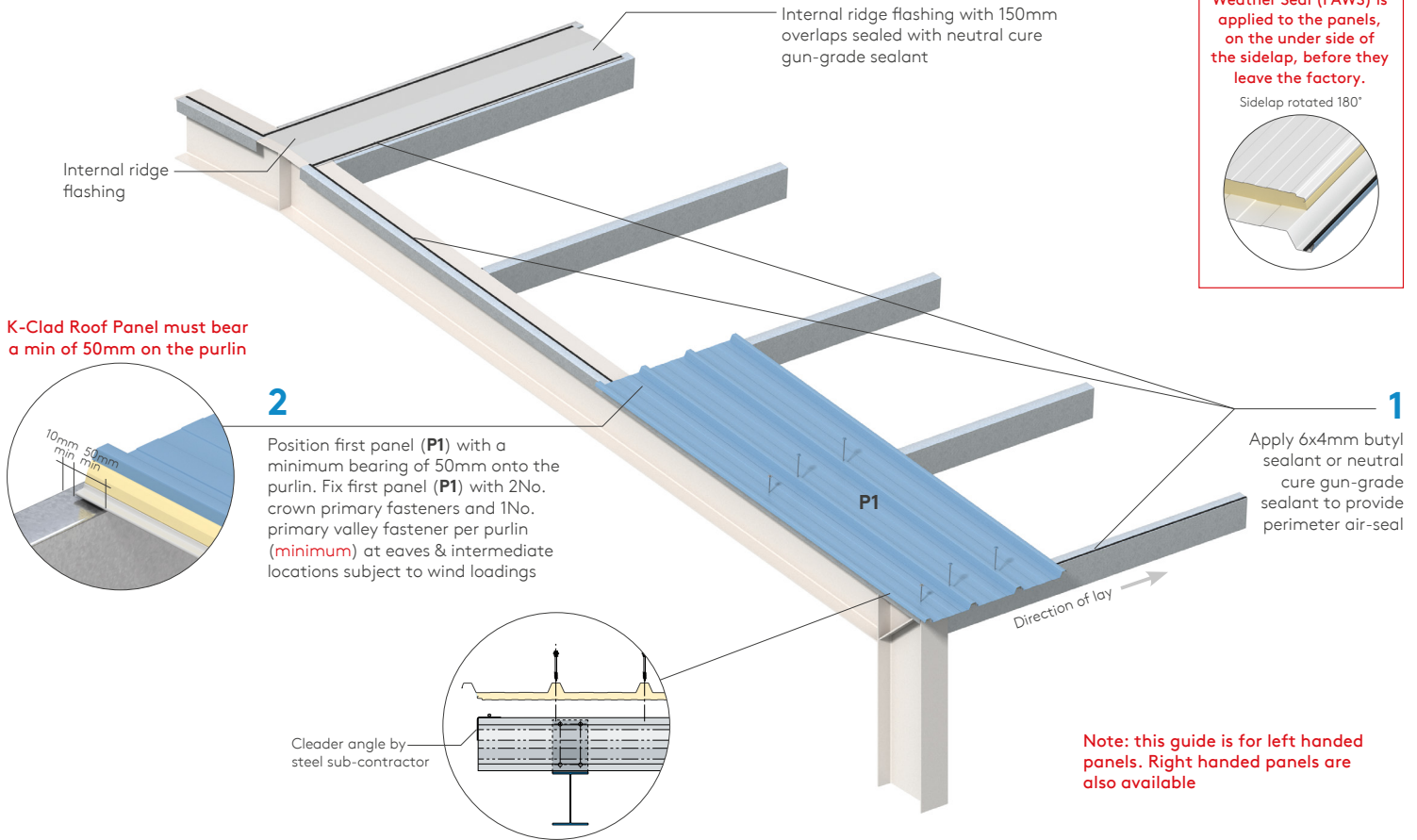

SIDELAP
 A Factory Applied Weather Seal (FAWS) is applied to the panels, on the under side of the sidelap, before they leave the factory.
 Sidelap rotated 180°

K-Clad Roof Panel must bear a min of 50mm on the purlin

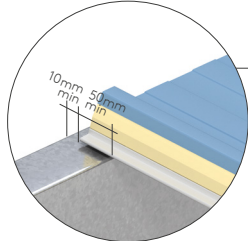

2

Position first panel (P1) with a minimum bearing of 50mm onto the purlin. Fix first panel (P1) with 2No. crown primary fasteners and 1No. primary valley fastener per purlin (**minimum**) at eaves & intermediate locations subject to wind loadings

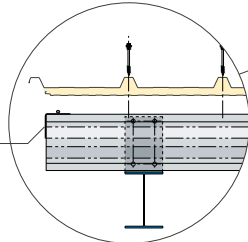

Cleaver angle by steel sub-contractor

1

Apply 6x4mm butyl sealant or neutral cure gun-grade sealant to provide perimeter air-seal

Note: this guide is for left handed panels. Right handed panels are also available

K-Clad Roof Panel

Multiple Panels Eaves to Ridge

150mm End Lap

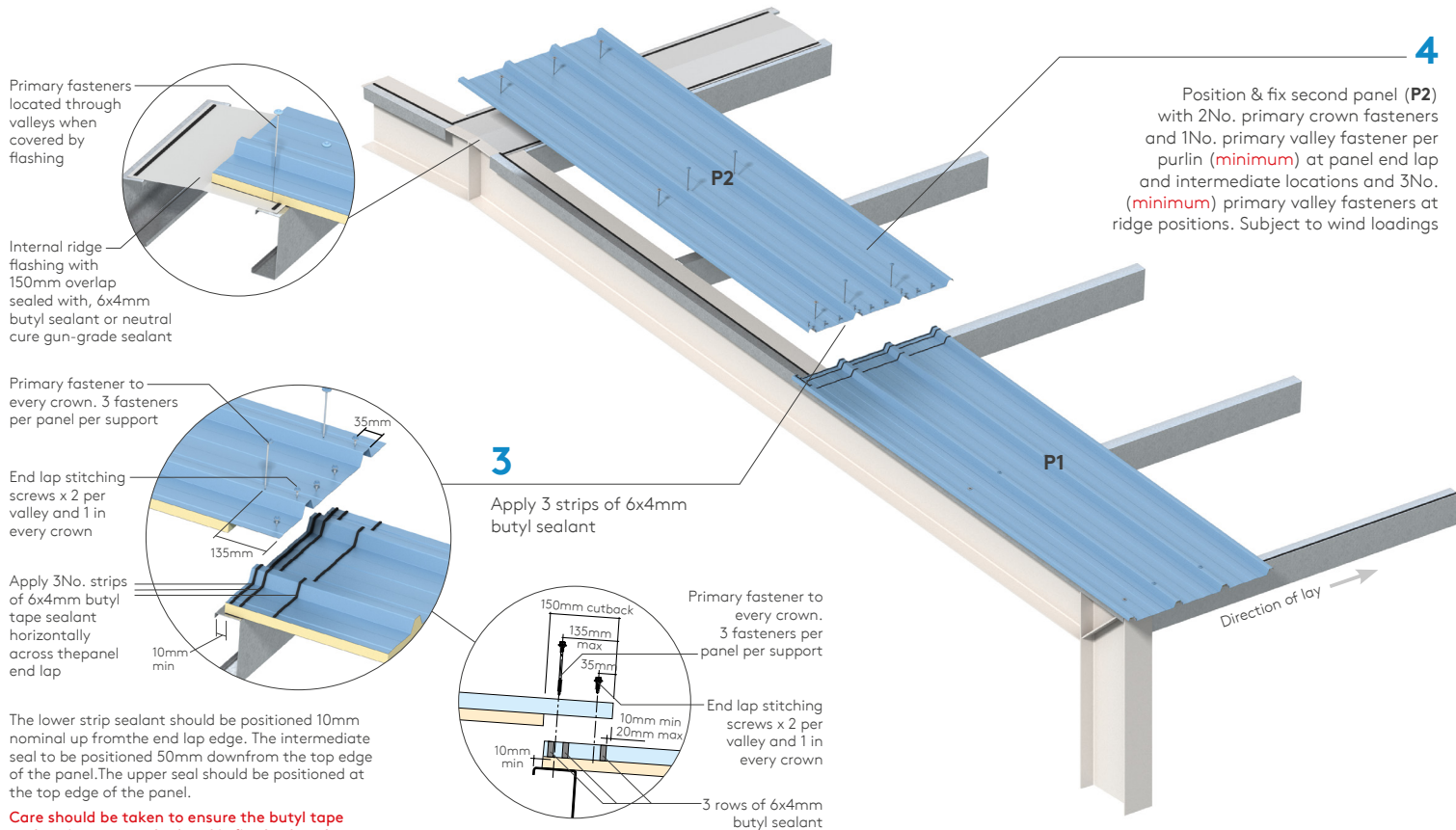

K-Clad Roof Panel

Multiple Panels Eaves to Ridge

150mm End Lap

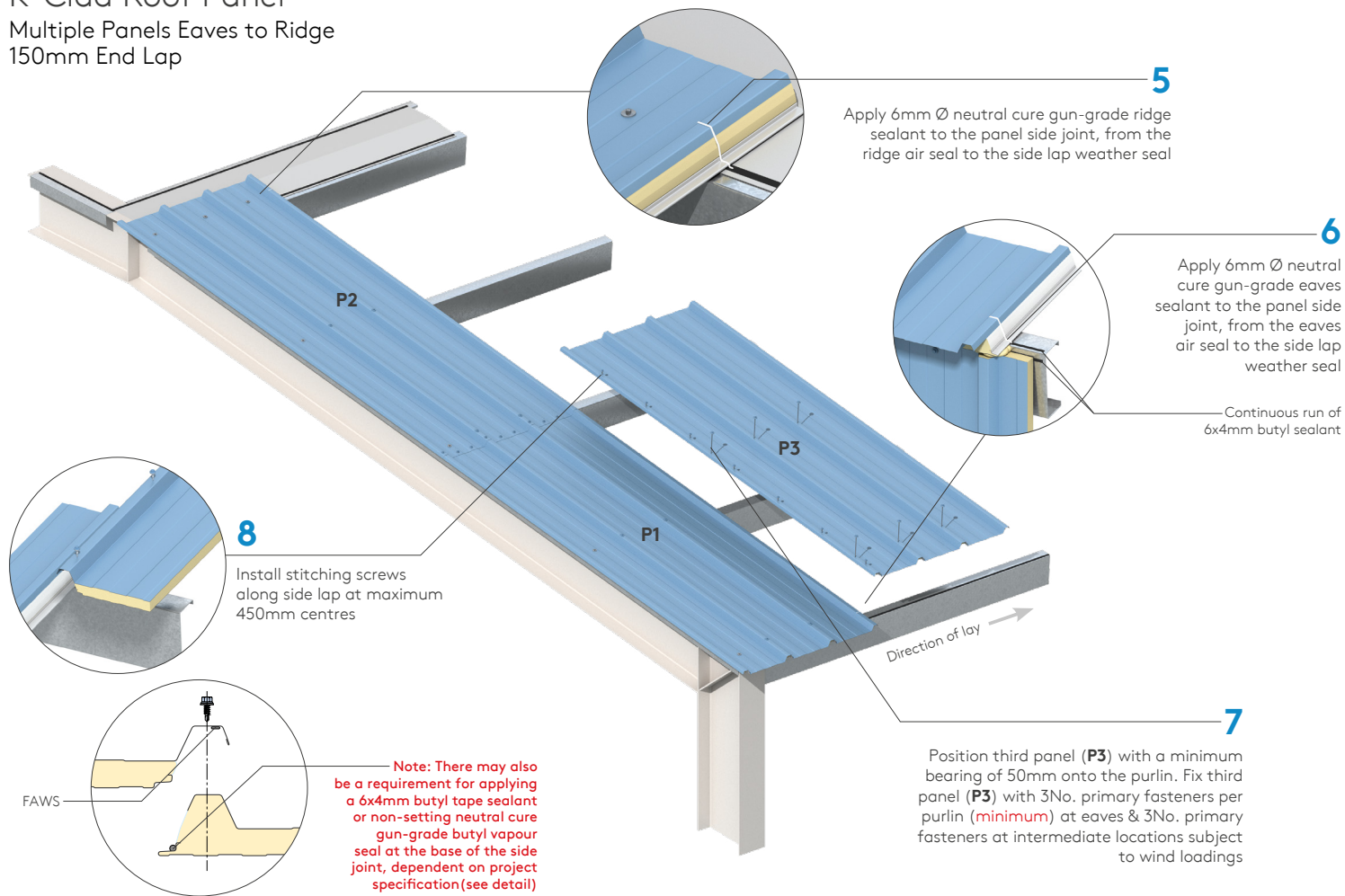

K-Clad Roof Panel

150mm End Lap

10

Position & fix fourth panel (P4) with 3No. Primary fasteners per purlin (**minimum**) at panel end lap & ridge position & 3No. (**minimum**) at intermediate locations subject to wind loadings. Add stitching screws along side lap at 450mm centres maximum commencing above main fastener

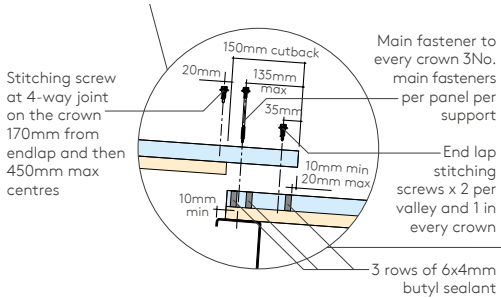

9

Apply 3 strips of 6x4mm butyl sealant as per point '3'

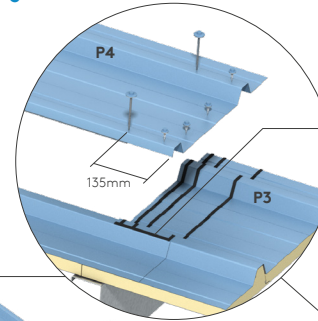

Apply 150mm length 6x4mm butyl tape sealant to the weatherside of the side lap, leaving sufficient area on the crown to abut with 3 No. strips 6x4mm butyl tape end lap sealant

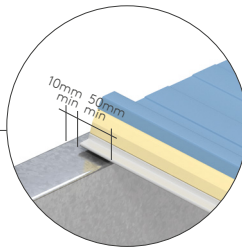
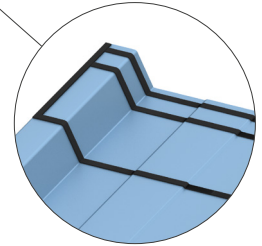

Direction of lay →

K-Clad Roof Panel

Multiple Panels Eaves to Ridge
150mm End Lap

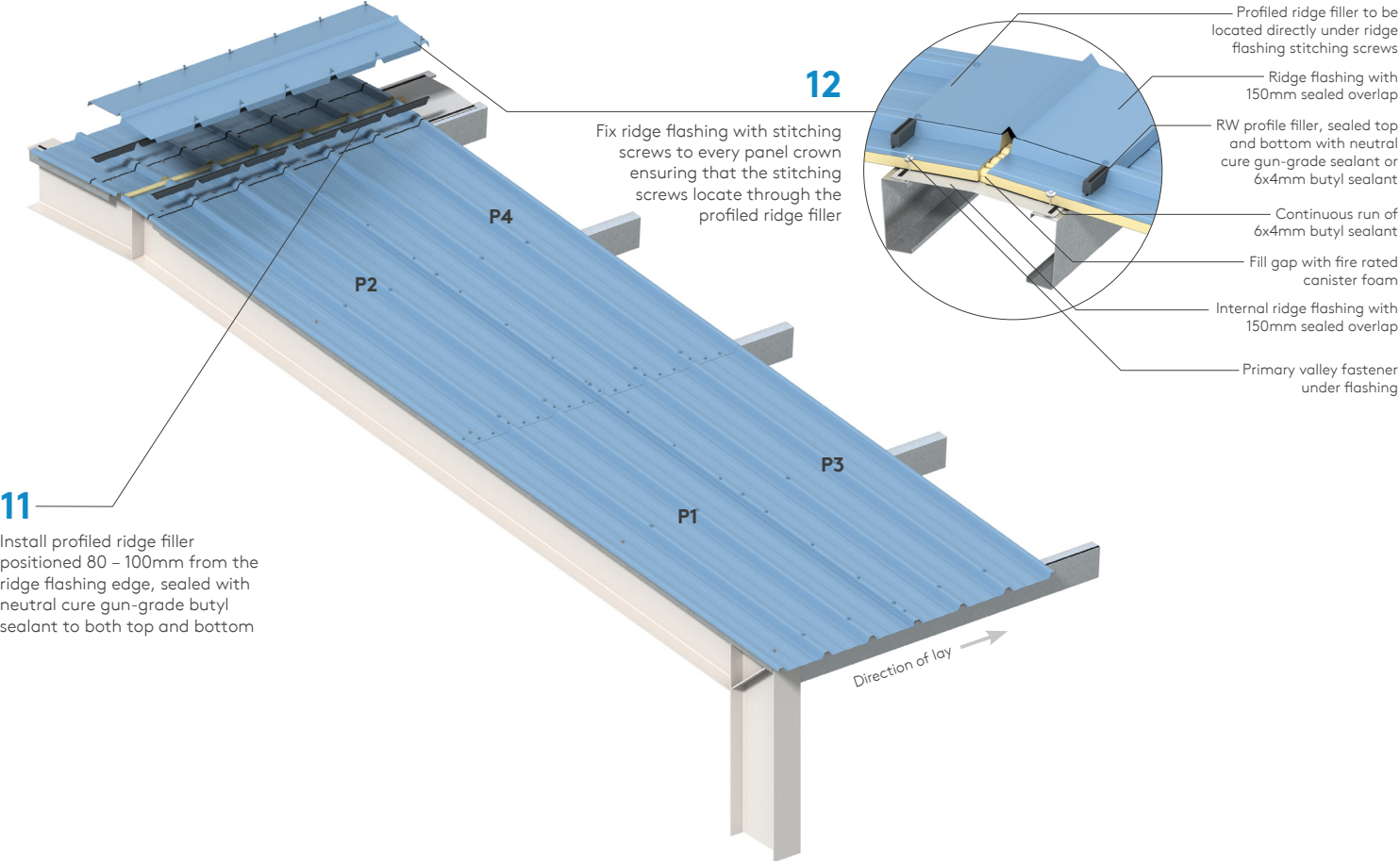

K-Clad Roof Panel

Multiple Panels Eaves to Ridge
150mm End Lap

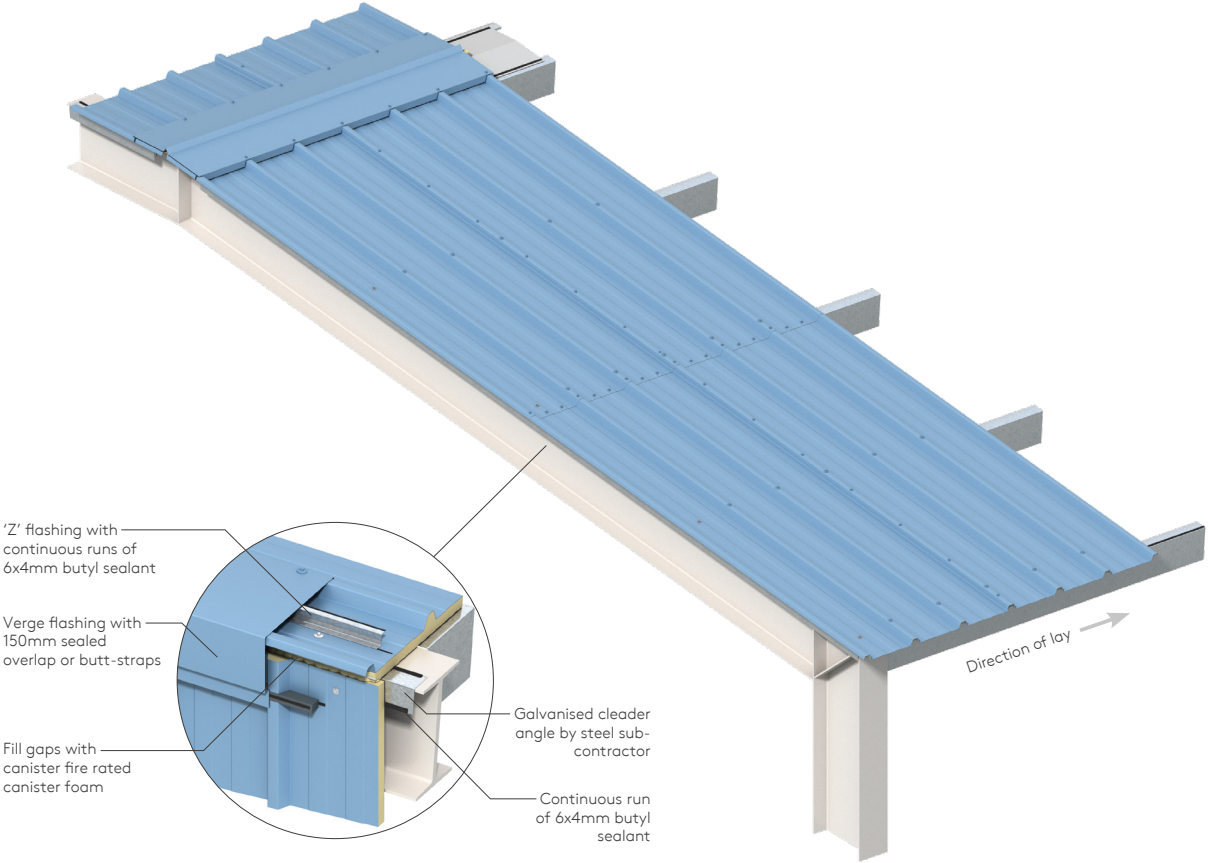

K-Clad Roof Panel Fabrications

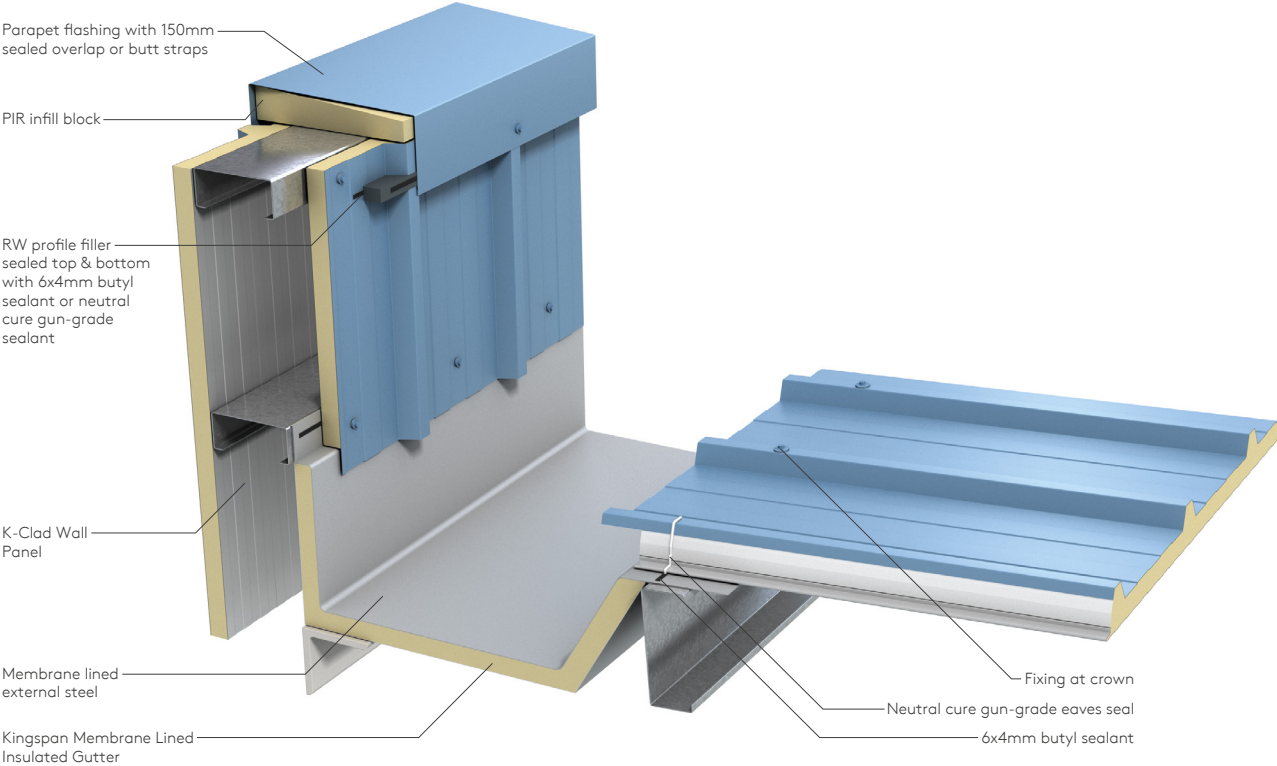

Panel Handling

Appropriate personnel protective equipment should always be worn to avoid cuts and abrasions to installers and panels.

Individual panels should always be lifted from a pack and not dragged over others.

The weight of individual panels for lifting can be determined from the information on the packing slip.

For larger panels the contractor would normally arrange to use appropriate material installation equipment to help lift the panels into position.

Protecting Film

When panels are supplied with a plastic protective film this should be removed during site installation.

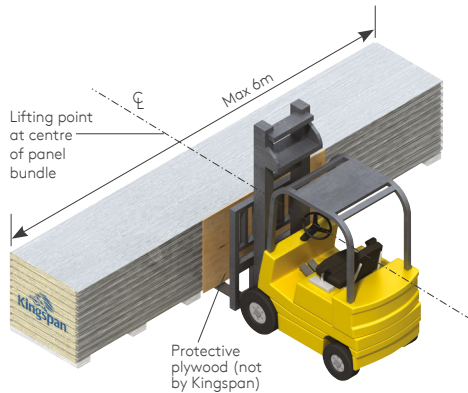

The recommended loading / unloading method for bundles less than or equal to 6m is to use a single forklift with widely spaced forks placed under the centre of the bundle as shown.

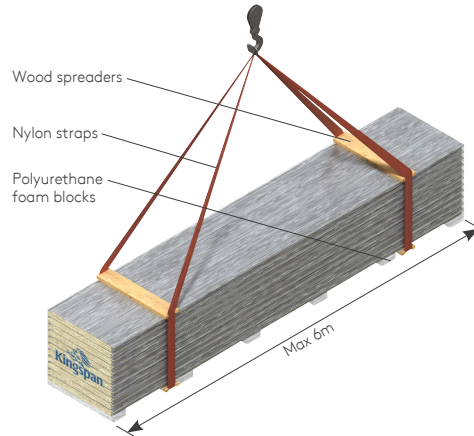

The recommended lifting method for bundles no more than or equal to 6m can be handled with a crane by using nylon straps and wood spreaders as shown.

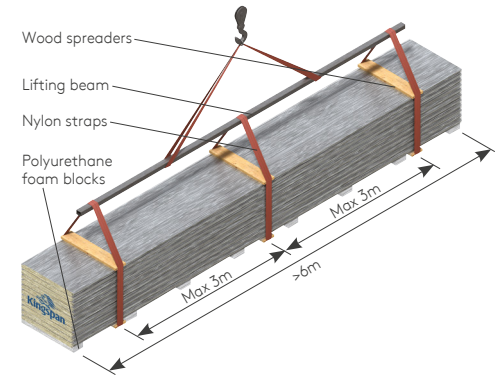

The recommended lifting method for bundles more than 6m, by crane, is by using three points of support. To prevent damage from nylon straps, use wood spreaders at top and bottom at lifting locations as shown.

Panel Handling

Correct and Incorrect Panel Handling

Caution

Individual panels should never be moved in a flat position as excessive flexing may result. Excessive flexing ruptures a panel's core, permanently distorts the facings and may lead to thermal blistering. When moving a panel, it must be turned on its edge first, then supported at each end with as many men as necessary to safely handle.

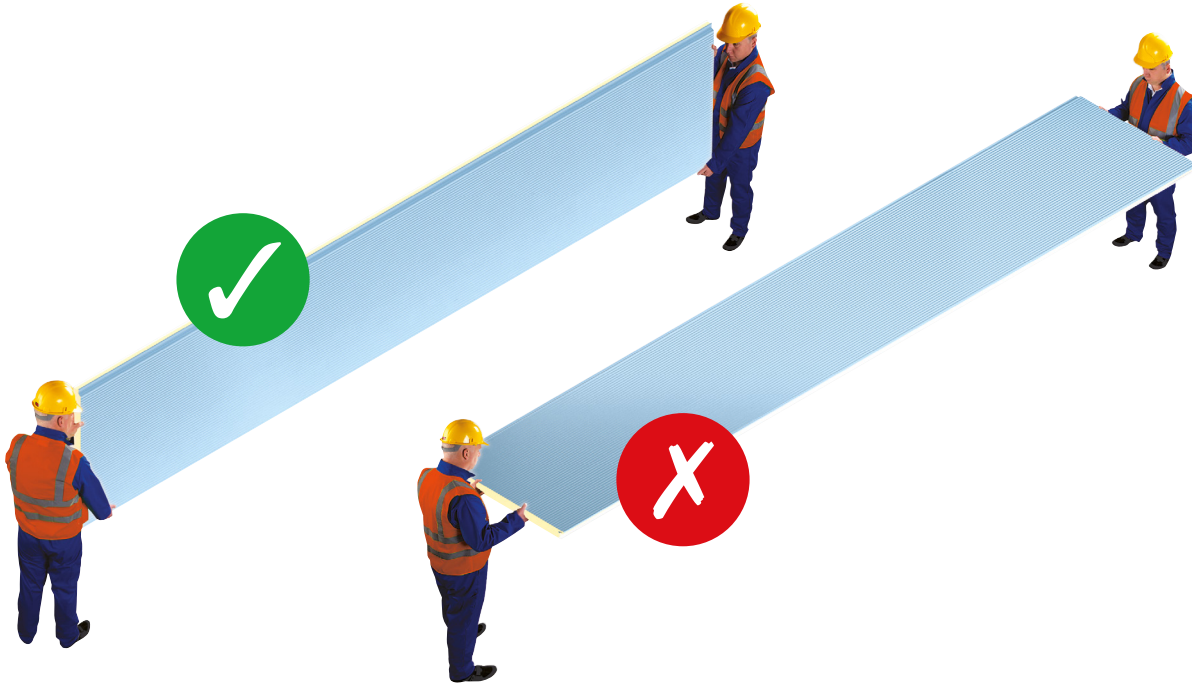

Installation guides are available for most of Kingspan insulated roof and wall panels.
For the most up to date version of this Installation guide please [click here](#) or scan the QR code below.
Alternatively, please call Kingspan on:

AUS: +61 2 8889 3000
www.kingspanpanels.com.au



For the product offering in other markets please contact your local sales representative or visit www.kingspanpanels.com

Care has been taken to ensure that the contents of this publication are accurate, but Kingspan Insulated Panels and its subsidiary companies do not accept responsibility for errors or for information that is found to be misleading. Suggestions for, or description of, the end use or application of products or methods of working are for information only and Kingspan Insulated Panels and its subsidiaries accept no liability in respect thereof.

First Issue | 27/06/2024

