

FIELDERS FACT FILE

FILE REFERENCE NUMBER: F3.5 /// APR 2018

ASYMMETRIC BEAMS FOR FIELDERS SLIMFLOR® CONSTRUCTION — BEAM SELECTION TABLES

This fact file provides quick selection tables for the optimum selection of primary steel beams in a Fielders SlimFlor® floor grid solution.

FIELDERS SLIMFLOR®

SlimFlor® utilises Fielders SlimDek 210™ flooring profile in conjunction with Asymmetric Steel Beam Sections (ASB) to provide a floor system with a reduced construction zone. It does this by combining the floor slab and supporting structure in the same plane, providing a lightweight, versatile, long spanning floor system.

An ASB is manufactured in one of two forms:

1. Either by welding plates to form a customised welded beam (ASB) with a bottom flange wider than the top (refer to Figure F3.5.2 for details), or
2. By welding an additional plate to the bottom flange of a UC or UB section (refer to Figure F3.5.3 for details) referred to as the ASB(UC).

The wider flange offers a bearing surface for the Fielders SlimDek 210™ profile to be supported on.

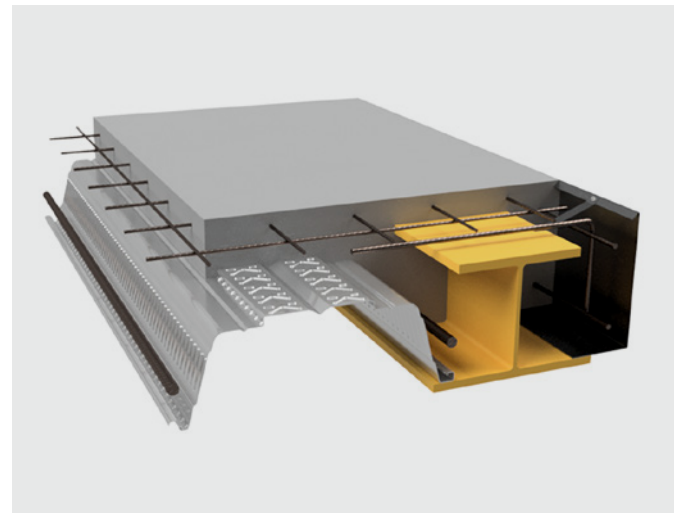

Figure F3.5.1 Fielders SlimFlor®

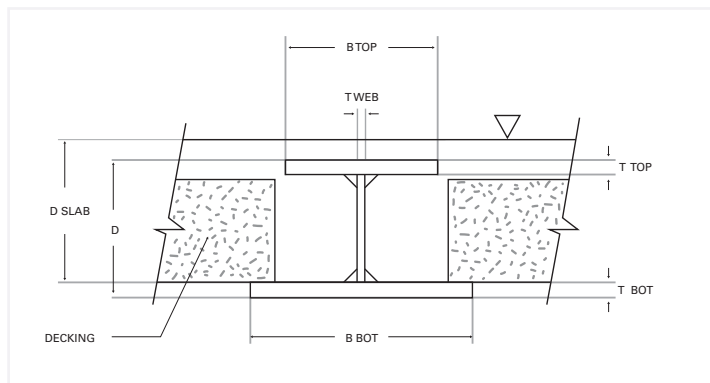

Figure F3.5.2 CUSTOM ASB

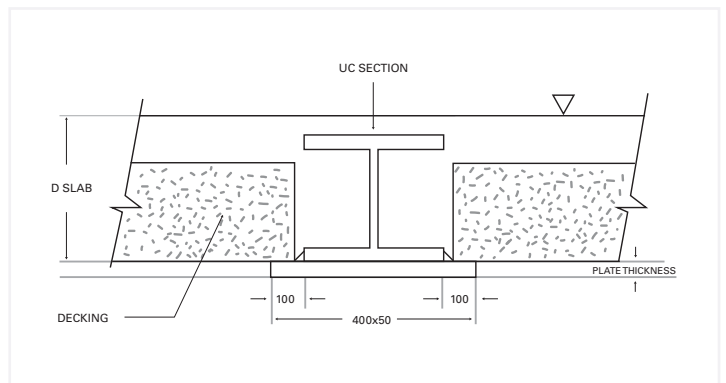

Figure F3.5.3 CUSTOM ASB (UC)

This total floor system has a construction depth of 290 to 310mm (shown as D SLAB in the Figures above) minimum with an equivalent weight of a 120 to 140mm concrete slab (comparison only taking slab weights into consideration), due to the SlimDek 210™ formwork profile displacing the equivalent of 170mm of concrete from the slab profile.

CUSTOMISED ASB

A customised ASB (Custom ASB) can be specified allowing for the most economical and effective size and configuration of beam to suit project design requirements. The customised ASB is manufactured by welding 3 flat plates together to create an ASB with a bottom flange wider than the top. The web is welded to the flanges on both sides with a deep penetration continuous fillet weld in accordance with AS/NZS 1554.1.

When nominating the size of your customised ASB for manufacture use the following nomenclature:

- $D / B_{top} / B_{bot} / T_{top} / T_{bot} / T_{web} /$ Grade of steel
- The typical ranges for the sizes of plates are 200-1800mm for the web, 100-600mm for the flanges, with a gauge of 8, 10, 12, 16, 20, 25, 28, 32, 36 & 40mm.
- Material grade is G350MPa.
- 12m length maximum.

Note: The library files for the ASB sections can be made available by contacting Fielders.

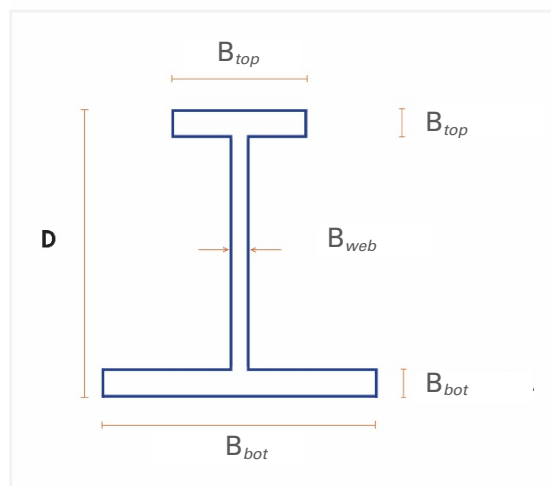

Figure F.3.5.4 Dimensions of CUSTOM ASB

ASB(UC)

Alternatively, the ASB(UC)'s utilise the standard range of available UC and UB sections with a plate welded to the bottom flange where the plate is approximately 200mm wider than the bottom flange.

The beams can be modeled in a Finite Element Analysis software package such as SpaceGass* or Microstran or by first principles.

Note: * Torsional capacity is an estimate. To undertake a steel design in SpaceGass an equivalent single bottom flange must be modelled rather than a UC/UB+ Plate.

BEAM SELECTION TABLES

The following four (4) tables offer quick selection tables for determining the right ASB for your project.

The loading configurations considered are;

- Residential
- Carpark
- Commercial
- Retail

All design assumptions can be found in the notes to each table. The cells in the tables are split as detailed below:

CUSTOMASB (Px) ASB(UC) (Px) <hr/> y	Where x is the precamber in the beam in mm's and y is the ratio of weight of the CUSTOMISED ASB/ASB(UC).
--	--

For 320ASB(UC)'s and deeper, two SHS packers or similar have been included in the weight of the section. These packers allow for the SlimDek 210™ profile to be placed at the optimal height for the slab thickness and not increasing the concrete requirements unnecessarily. However, the cost of the welding of these packers onto the bottom plate and other associated costs of manufacturing and handling need to be taken into consideration when determining if this section is an economical solution. Refer to Figure 3.5.4.

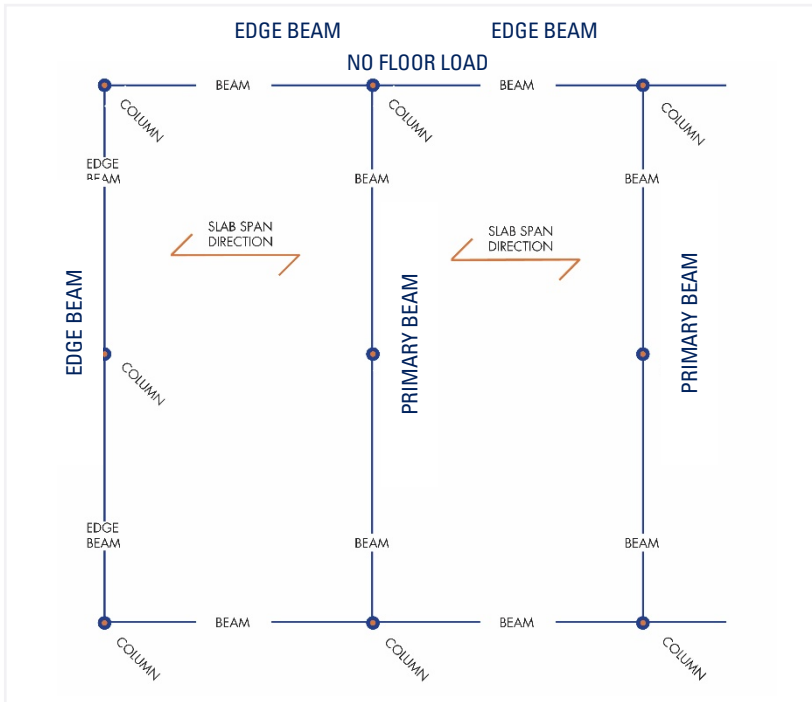

Figure F.3.5.4 Dimensions of CUSTOM ASB

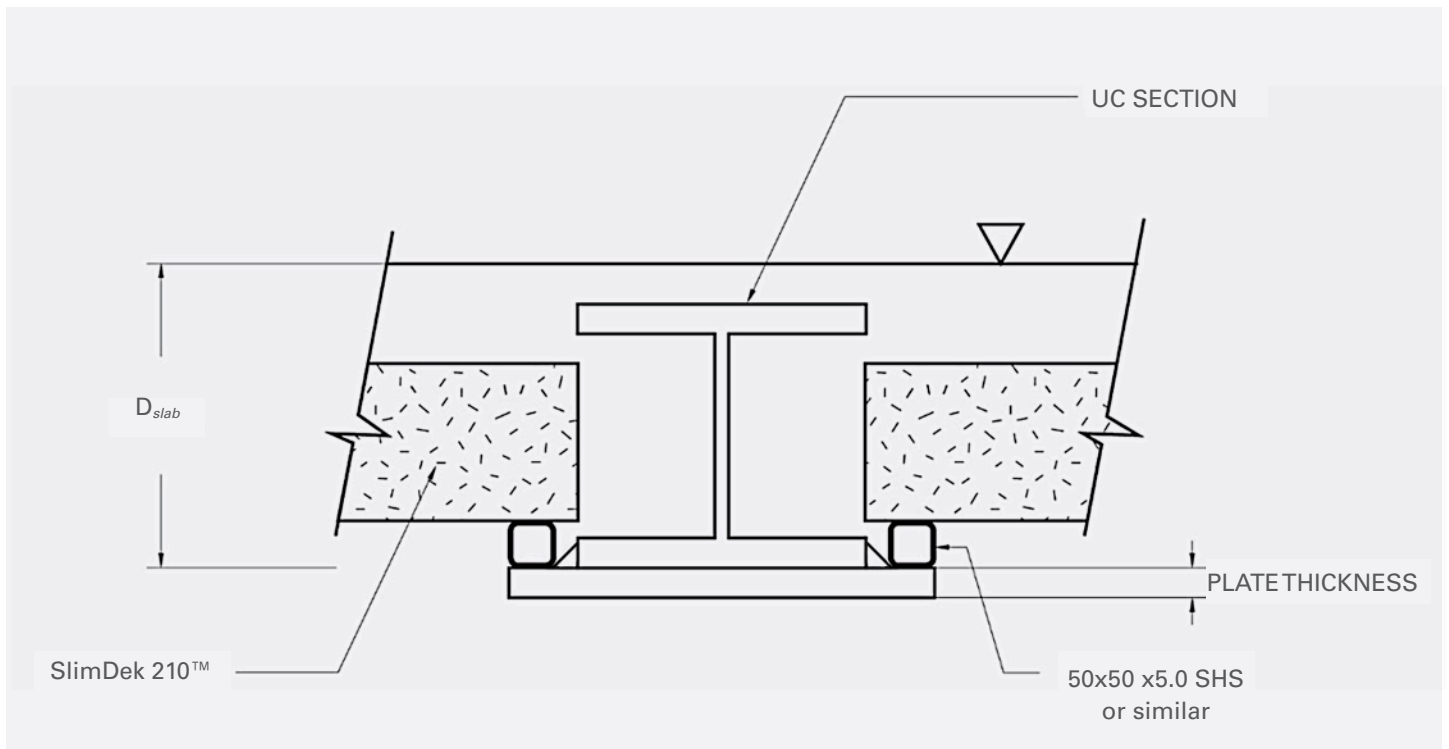

Figure F.3.5.4 Dimensions of CUSTOM ASB

Note: The design of the edge beams and the beams parallel to the SlimDek 210™ are outside the scope of this fact file. For further information contact Fielders technical department at fielders.com.au the nomenclature of the beams is detailed in *Appendix A* of this document.

RESIDENTIAL

RESIDENTIAL LL 2.0kPa SDL 1.5kPa

Slab Span (m)	Beam Span (m)					
	5	6	7	7.5	8	8.4
5	258CUSTOMASB388 (P10) 210ASB(UC)780 0.50	258CUSTOMASB600 (P10) 260ASB(UC)1088 0.55	266CUSTOMASB963 (P20) 260ASB(UC)1088 (P20) 0.89	266CUSTOMASB1118 (P20) 270ASB(UC)1444 (P20) 0.77	270CUSTOMASB1429 (P20) 270ASB(UC)1611 (P20) 0.89	270CUSTOMASB1605 (P20) 282ASB(UC)2040 (P20) 0.79
6	260CUSTOMASB450 (P10) 210ASB(UC)840 0.54	262CUSTOMASB724 (P10) 260ASB(UC)1088 0.67	270CUSTOMASB1201 (P20) 266ASB(UC)1468 0.82	270CUSTOMASB1393 (P20) 270ASB(UC)1611 (P20) 0.87	275CUSTOMASB1613 (P20) 282ASB(UC)2040 (P20) 0.79	275CUSTOMASB1853 (P20) 320ASB(UC)1659 [†] (P20) 1.12
7	258CUSTOMASB529 (P10) 210ASB(UC)916 0.58	266CUSTOMASB874 (P10) 260ASB(UC)1088 0.80	275CUSTOMASB1358 (P20) 270ASB(UC)1611 (P20) 0.84	275CUSTOMASB1550 (P20) 320ASB(UC)1455 [†] (P20) 1.07	275CUSTOMASB2036 (P20) 320ASB(UC)1659 [†] (P20) 1.23	282CUSTOMASB2283 (P20) 320ASB(UC)1855 [†] (P20) 1.23
7.5	258CUSTOMASB529 (P10) 212ASB(UC)980 0.54	260CUSTOMASB914 (P10) 260ASB(UC)1088 0.84	270CUSTOMASB1393 (P20) 278ASB(UC)1897 (P20) 0.73	275CUSTOMASB1684 (P20) 320ASB(UC)1455 [†] (P20) 1.16	275CUSTOMASB2036 (P20) 320ASB(UC)1659 [†] (P20) 1.23	282CUSTOMASB2352 (P20) 326ASB(UC)2067 [†] (P20) 1.38
8	260CUSTOMASB584 (P10) 260ASB(UC)1088 0.54	266CUSTOMASB963 (P10) 262ASB(UC)1324 0.73	270CUSTOMASB1437 (P20) 282ASB(UC)2040 (P20) 0.70	275CUSTOMASB1782 (P20) 322ASB(UC)1525 [†] (P20) 1.17	282CUSTOMASB2283 (P20) 326ASB(UC)1871 [†] (P20) 1.22	335CUSTOMASB1706 (P20) 330ASB(UC)2208 [†] (P20) 0.77
8.4	260CUSTOMASB709 (P10) 260ASB(UC)1088 0.65	266CUSTOMASB1100 (P20) 278ASB(UC)1897 0.58	270CUSTOMASB1605 (P30) 322ASB(UC)1727 [†] 0.93	275CUSTOMASB1853 (P30) 320ASB(UC)2059 [†] 0.90	330CUSTOMASB1662 (P30) 330ASB(UC)2412 [†] (P20) 0.69	335CUSTOMASB1838 (P20) 330ASB(UC)2208 [†] (P20) 0.83

DESIGN CRITERIA:

1. Residential span table allows SDL=1.5kPa and LL=2.0kPa
2. Residential span table is based on a 290 thick CF210 slab UNO (see Note 10).
3. Total deflection limit = span/250
4. Incremental deflection limit = span/500
5. In choosing appropriate slab span, designer is to allow for moment-shear effect in continuous slabs.
6. Beam design based on uniformly distributed vertical load only on simply supported beam. No allowance made for other actions, including concentrated loads, concentrated moment or torque, lateral or axial load.
7. All plate G350.
8. No fire protection required to achieve 60 min FRL. For 90 min FRL, provide fire protection to bottom flange. Subject to fire design assessment by others.
9. 8.4m slab spans have been provided on the basis of a 360mm overall slab (190mm equivalent).
10. [†]indicates that 2x 50x50x5.0SHS packers are required welded to the bottom plate. Refer to Figure F.3.5.5.

////// ASYMMETRIC BEAMS FOR FIELDERS SLIMFLOR® CONSTRUCTION — BEAM SELECTION TABLES

CARPARK LL 2.5kPa SDL 0.5kPa

CAR PARK

Slab Span (m)	Beam Span (m)			
	5	6	7	7.5
5	258CUSTOMASB365 210ASB(UC)780 ————— 0.47	260CUSTOMASB526 (P20) 210ASB(UC)840 (P20) ————— 0.63	260CUSTOMASB736 (P20) 260ASB(UC)1088 ————— 0.68	266CUSTOMASB901 (P20) 260ASB(UC)1088 (P20) ————— 0.83
6	260CUSTOMASB465 210ASB(UC)780 ————— 0.60	260CUSTOMASB573 (P20) 210ASB(UC)916 (P20) ————— 0.63	262CUSTOMASB901 (P20) 260ASB(UC)1088 (P20) ————— 0.83	279CUSTOMASB1086 (P20) 260ASB(UC)1253 (P20) ————— 0.87
7	260CUSTOMASB487 210ASB(UC)840 ————— 0.58	260CUSTOMASB673 (P20) 260ASB(UC)1088 ————— 0.62	266CUSTOMASB1026 (P20) 260ASB(UC)1253 (P20) ————— 0.82	270CUSTOMASB1217 (P20) 262ASB(UC)1324 (P20) ————— 0.92
7.5	262CUSTOMASB526 210ASB(UC)840 ————— 0.63	262CUSTOMASB728 (P20) 260ASB(UC)1088 ————— 0.67	266CUSTOMASB1063 (P20) 260ASB(UC)1253 (P20) ————— 0.85	275CUSTOMASB1354 (P20) 278ASB(UC)1897 (P20) ————— 0.71

DESIGN CRITERIA:

1. Carpark span table allows SDL=0.5kPa and LL=2.5kPa
2. Carpark span table is based on a 290 thick CF210 slab.
3. Total deflection limit = span/250
4. Incremental deflection limit = span/500
5. In choosing appropriate slab span, designer is to allow for moment-shear effect in continuous slabs.
6. Beam design based on uniformly distributed vertical load only on simply supported beam. No allowance made for other actions, including concentrated loads, concentrated moment or torque, lateral or axial load.
7. All plate G350.
8. No fire protection required to achieve 60 min FRL. For 90 min FRL, provide fire protection to bottom flange. Subject to fire design assessment by others.
9. In some instances CUSTOMASB is heavier than ASB(UC) as a result of adopting thicker plate gauges in order to maintain a maximum CUSTOMASB depth of 250mm to maintain floor construction zone effectiveness.



////// ASYMMETRIC BEAMS FOR FIEDLERS SLIMFLOR® CONSTRUCTION — BEAM SELECTION TABLES

COMMERCIAL LL 3.0kPa SDL 1.5kPa

COMMERCIAL

Slab Span (m)	Beam Span (m)			
	5	6	7	7.5
5	260CUSTOMASB465 (P20) 210ASB(UC)840 <hr/> 0.55	262CUSTOMASB681 (P20) 260ASB(UC)1088 <hr/> 0.63	270CUSTOMASB1040 (P20) 260ASB(UC)1253 <hr/> 0.83	270CUSTOMASB1280 (P20) 262ASB(UC)1324 (P20) <hr/> 0.97
6	260CUSTOMASB532 (P20) 210ASB(UC)916 <hr/> 0.58	262CUSTOMASB827 (P20) 260ASB(UC)1088 <hr/> 0.76	270CUSTOMASB1217 (P20) 260ASB(UC)1468 (P20) <hr/> 0.83	270CUSTOMASB1400 (P20) 282ASB(UC)2040 (P20) <hr/> 0.69
7	266CUSTOMASB649 (P20) 260ASB(UC)1088 <hr/> 0.60	266CUSTOMASB901 (P20) 260ASB(UC)1253 <hr/> 0.72	270CUSTOMASB1393 (P20) 266ASB(UC)2040 (P20) <hr/> 0.68	275CUSTOMASB1747 (P20) 320ASB(UC)1659 [†] <hr/> 1.05
7.5	262CUSTOMASB663 (P20) 260ASB(UC)1088 <hr/> 0.61	266CUSTOMASB1013 (P20) 260ASB(UC)1253 <hr/> 0.81	270CUSTOMASB1473 (P20) 320ASB(UC)1455 [†] (P20) <hr/> 1.01	278CUSTOMASB1968 (P20) 320ASB(UC)1659 [†] (P20) <hr/> 1.19

DESIGN CRITERIA:

- Commercial span table allows SDL=1.5kPa and LL=3.0kPa
- Commercial span table is based on a 310 thick CF210 slab.
- Total deflection limit = span/250
- Incremental deflection limit = span/500
- In choosing appropriate slab span, designer is to allow for moment-shear effect in continuous slabs.
- Beam design based on uniformly distributed vertical load only on simply supported beam. No allowance made for other actions, including concentrated loads, concentrated moment or torque, lateral or axial load.
- All plate G350.
- Provide fire protection to bottom flange to achieve 120 min FRL.
- In some instances CUSTOMASB is heavier than ASB(UC) as a result of adopting thicker plate gauges in order to maintain a maximum CUSTOMASB depth of 250mm to maintain floor construction zone effectiveness.
- [†] indicates that 2x 50x50x5.0SHS packers are required welded to the bottom plate. Refer to Figure F.3.5.5.

////// ASYMMETRIC BEAMS FOR FIELDERS SLIMFLOR® CONSTRUCTION — BEAM SELECTION TABLES

RETAIL LL 5.0kPa SDL 2.5kPa

RETAIL

Slab Span (m)	Beam Span (m)			
	5	6	7	7.5
5	270CUSTOMASB806	270CUSTOMASB1165	275CUSTOMASB1933	282CUSTOMASB2352
	260ASB(UC)1088	262ASB(UC)1324	322ASB(UC)1727 [†]	320ASB(UC)1855 [†]
	0.74	0.88	1.12	1.27
6	270CUSTOMASB869	270CUSTOMASB1461	282CUSTOMASB2181	335CUSTOMASB1794
	260ASB(UC)1088	275ASB(UC)1790	322ASB(UC)1926 [†]	322ASB(UC)2130 [†]
	0.80	0.82	1.13	0.84
7	270CUSTOMASB1008	270CUSTOMASB1665	282CUSTOMASB2818	335CUSTOMASB2111
	260ASB(UC)1253	320ASB(UC)1455 [†]	326ASB(UC)2067 [†]	330ASB(UC)2412
	0.80	1.14	1.36	0.88
7.5	270CUSTOMASB1086	275CUSTOMASB1842	282CUSTOMASB3077	342CUSTOMASB2359
	260ASB(UC)1253	322ASB(UC)1525 [†]	330ASB(UC)2208 [†]	338ASB(UC)2695 [†]
	0.87	1.21	1.39	0.88

DESIGN CRITERIA:

1. Retail span table allows SDL=2.5kPa and LL=5.0kPa
2. Retail span table is based on a 310 thick CF210 slab UNO.
3. Total deflection limit = span/250
4. Incremental deflection limit = span/500
5. In choosing appropriate slab span, designer is to allow for moment-shear effect in continuous slabs.
6. Beam design based on uniformly distributed vertical load only on simply supported beam. No allowance made for other actions, including concentrated loads, concentrated moment or torque, lateral or axial load.
7. All plate G350.
8. Provide fire protection to bottom flange to achieve 120 FRL.
9. [†]indicates that 2x 50x50x5.0SHS packers are required welded to the bottom plate. Refer to Figure F.3.5.5.

FIRE

All beams have been designed to take the fire loading as detailed in the notes to the tables. To achieve the additional fire rating an intumescent paint system can be applied to the bottom flange of the beam. For more details on the fire design of asymmetric beams refer to the Fielders Fact File F3.6.

ACOUSTIC

For information on SlimFlor® and acoustic design refer to Fielders Fact File F3.7.

SLIMDEK 210™ SLAB DESIGN

For the design of the SlimDek 210™ slab refer to Fielders KingFlor® manual available for downloading at fielders.com.au/manuals-software/kingflor-manual

PLEASE CHECK WITH FIELDERS THAT YOU HAVE THE CURRENT FIELDERS FACT FILE FOR THIS TOPIC.

Care has been taken to ensure that the design information herein is accurate, but Fielders Australia Pty Ltd and its agents do not accept responsibility for errors due to misinterpretation of the input data or of output information by the user. Design advice is provided as a recommendation only and is not a substitute for professional judgment. Damages for breach of any warranty conditions shall not extend to any consequential damages.

The information contained in this design advice remains the property of Fielders Australia and is submitted in strict confidence for the sole purpose of facilitating the exclusive specification and use of Fielders products. The information contained within this advice is based on testing conducted by and exclusive to Fielders profiles and cannot be assumed to apply to alternative products. Distribution of this and associated documents, is restricted to the following parties unless otherwise authorised by Fielders Australia.

The product information presented in this brochure is intended as a guide only. It is recommended that you obtain qualified expert advice when seeking confirmation of product application. More comprehensive information can be sourced from your local Fielders' Technical Representative.

////// ASYMMETRIC BEAMS FOR FIELDERS SLIMFLOR® CONSTRUCTION — BEAM SELECTION TABLES

APPENDIX A

The beam I.D for Asymmetric beams is detailed by the overall depth of the beam and the beams weight in kg/m, i.e. 258CUSTOM365 is a 258mm deep customized beam with a weight of 36.5 kg/m.

BEAMS SIZES WELDED CUSTOMISED ASB'S

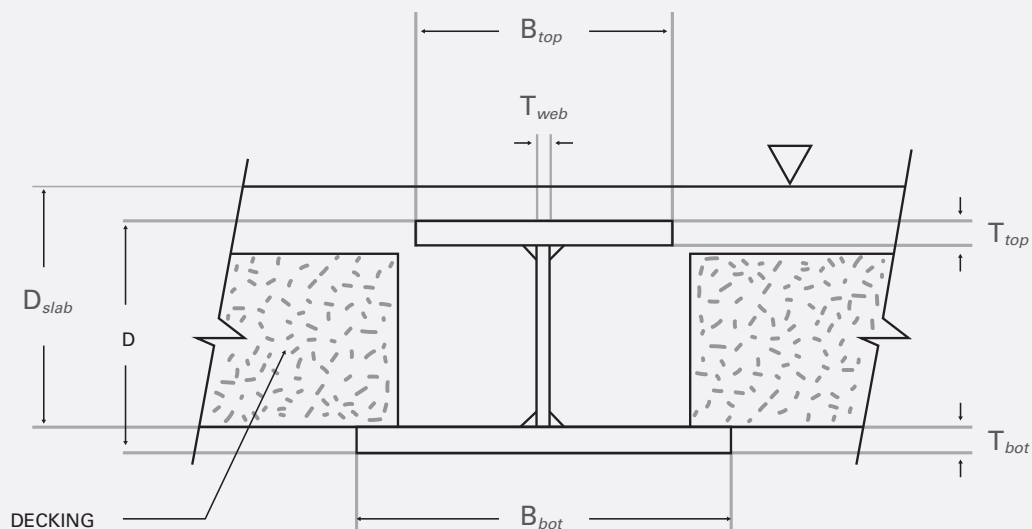

Beam ID	Depth of Beam (mm)	Width of top Flange (mm)	Width of bottom Flange (mm)	Thickness of top flange (mm)	Thickness of bottom flange (mm)	Thickness of web (mm)	Mass of section (kg/m)
	D	B _T	B _τ	T _T	T _B	T _W	
258CUSTOMASB365	258	150	250	8	8	6	36.5
258CUSTOMASB388	258	150	250	10	8	6	38.8
258CUSTOMASB529	258	250	350	10	8	6	52.9
258CUSTOMASB600	258	300	400	10	8	6	60.0
260CUSTOMASB450	260	150	250	12	10	6	45.0
260CUSTOMASB465	260	150	250	10	10	8	46.5
260CUSTOMASB487	260	150	250	12	10	8	48.7
260CUSTOMASB526	260	150	300	12	10	8	52.6
260CUSTOMASB532	260	150	250	16	10	8	53.2
260CUSTOMASB573	260	200	300	12	10	8	57.3
260CUSTOMASB584	260	250	350	10	10	6	58.4
260CUSTOMASB673	260	200	350	16	10	8	67.3
260CUSTOMASB709	260	300	400	12	10	6	70.9
260CUSTOMASB736	260	250	350	16	10	8	73.6
260CUSTOMASB914	260	300	450	16	10	10	91.4
262CUSTOMASB663	262	150	300	20	12	8	66.3
262CUSTOMASB526	262	150	250	12	12	8	52.6
262CUSTOMASB681	262	200	300	16	12	8	68.1

////// ASYMMETRIC BEAMS FOR FIEDLERS SLIMFLOR® CONSTRUCTION — BEAM SELECTION TABLES

BEAMS SIZES WELDED CUSTOMISED ASB'S - CONTINUED

Beam ID	Depth of Beam (mm)	Width of top Flange (mm)	Width of bottom Flange (mm)	Thickness of top flange (mm)	Thickness of bottom flange (mm)	Thickness of web (mm)	Mass of section (kg/m)
	D	B _T	B _B	T _T	T _B	T _W	
262CUSTOMASB724	262	250	400	12	12	6	72.4
262CUSTOMASB728	262	200	350	16	12	8	72.8
262CUSTOMASB827	262	250	350	16	12	10	82.7
262CUSTOMASB901	262	300	400	16	12	8	90.1
266CUSTOMASB1013	266	250	350	20	16	10	101.3
266CUSTOMASB1026	266	300	400	16	16	8	102.6
266CUSTOMASB1063	266	300	400	16	16	10	106.3
266CUSTOMASB1100	266	300	400	16	16	12	110.0
266CUSTOMASB1118	266	300	400	20	16	8	111.8
266CUSTOMASB649	266	150	250	16	16	8	64.9
266CUSTOMASB874	266	200	350	16	16	10	87.4
266CUSTOMASB901	266	250	350	16	16	8	90.1
266CUSTOMASB901	266	250	350	16	16	8	90.1
266CUSTOMASB963	266	250	400	16	16	8	96.3
270CUSTOMASB1008	270	200	350	20	20	8	100.8
270CUSTOMASB1040	270	200	300	25	20	10	104.0
270CUSTOMASB1086	270	250	350	20	20	8	108.6
270CUSTOMASB1165	270	250	400	20	20	8	116.5
270CUSTOMASB1201	270	250	400	20	20	10	120.1
270CUSTOMASB1217	270	250	350	25	20	10	121.7
270CUSTOMASB1280	270	300	400	20	20	10	128.0
270CUSTOMASB1358	275	250	400	20	25	10	135.8
270CUSTOMASB1393	270	300	400	25	20	10	139.3
270CUSTOMASB1400	270	350	450	20	20	8	140.0
270CUSTOMASB1429	270	300	400	25	20	12	142.9
270CUSTOMASB1437	270	350	450	20	20	10	143.7
270CUSTOMASB1461	270	250	400	32	20	12	146.1
270CUSTOMASB1473	270	350	450	20	20	12	147.3
270CUSTOMASB1605	270	350	450	25	20	12	160.5
270CUSTOMASB1665	270	300	450	32	20	12	166.5
270CUSTOMASB806	270	150	300	16	20	8	80.6
275CUSTOMASB1354	275	250	350	25	25	10	135.4
275CUSTOMASB1550	275	300	400	25	25	10	155.0
275CUSTOMASB1613	275	350	450	20	25	10	161.3
275CUSTOMASB1684	275	300	450	25	25	12	168.4

////// ASYMMETRIC BEAMS FOR FIELDERS SLIMFLOR® CONSTRUCTION — BEAM SELECTION TABLES

BEAMS SIZES WELDED CUSTOMISED ASB'S - CONTINUED

Beam ID	Depth of Beam (mm)	Width of top Flange (mm)	Width of bottom Flange (mm)	Thickness of top flange (mm)	Thickness of bottom flange (mm)	Thickness of web (mm)	Mass of section (kg/m)
	D	B _T	B _B	T _T	T _B	T _W	
275CUSTOMASB1747	275	350	450	25	25	10	174.7
275CUSTOMASB1782	275	350	450	25	25	12	178.2
275CUSTOMASB1842	275	300	450	32	25	12	184.2
275CUSTOMASB1853	275	350	450	25	25	16	185.3
275CUSTOMASB1933	275	350	450	35	25	10	193.3
275CUSTOMASB2036	275	350	450	32	25	16	203.6
278CUSTOMASB1968	278	350	450	28	28	12	196.8
282CUSTOMASB2181	282	350	450	32	32	10	218.1
282CUSTOMASB2283	282	350	450	32	32	16	228.3
282CUSTOMASB2352	282	350	450	32	32	20	235.2
282CUSTOMASB2818	282	350	450	50	32	20	281.8
282CUSTOMASB3077	282	350	450	60	32	20	307.7
330CUSTOMASB1662	330	350	450	25	20	12	166.2
335CUSTOMASB1706	335	350	450	20	25	12	170.6
335CUSTOMASB1794	335	350	450	25	25	10	179.4
335CUSTOMASB1838	335	350	450	25	25	12	183.8
335CUSTOMASB2111	335	350	450	32	25	16	211.1
342CUSTOMASB2359	342	350	450	32	32	16	235.9

////// ASYMMETRIC BEAMS FOR FIELDERS SLIMFLOR® CONSTRUCTION — BEAM SELECTION TABLES

UC'S WITH WELDED PLATES

The beam id for Asymmetric beams is detailed by the overall depth of the beam and the beams weight in kg/m
 I.E. 210ASB(UC)780 is a 210mm deep ASB(UC) with a weight of 78.0 kg/m.

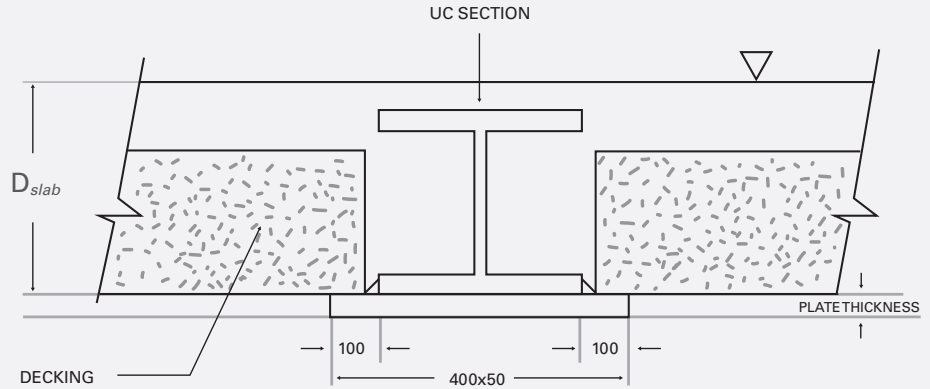

Beam ID	UC	Width of bottom plate (mm)	Thickness of bottom plate (mm)	Mass of section kg/m
210ASB(UC)780	200 UC 46.2	403	10	78.0
210ASB(UC)840	200 UC 52.2	404	10	84.0
210ASB(UC)916	200 UC 59.5	405	10	91.6
212ASB(UC)980	200 UC 59.5	405	12	98.0
220ASB(UC)1444	250 UC 72.9	454	20	144.4
260ASB(UC)1088	250 UC 72.9	454	10	108.8
260ASB(UC)1253	250 UC 89.5	456	10	125.3
262ASB(UC)1324	250 UC 89.5	456	12	132.4
266ASB(UC)1468	250 UC 89.5	456	16	146.8
270ASB(UC)1611	250 UC 89.5	456	20	161.1
275ASB(UC)1790	250 UC 89.5	456	25	179.0
278ASB(UC)1897	250 UC 89.5	456	28	189.7
282ASB(UC)2040	250 UC 89.5	456	32	204.0
320ASB(UC)1455 [†]	310 UC 96.8	505	10	145.5
322ASB(UC)1525 [†]	310 UC 96.8	505	12	152.5
320ASB(UC)1659 [†]	310 UC 118	507	10	165.9
322ASB(UC)1727 [†]	310 UC 118	507	12	172.7
320ASB(UC)1855 [†]	310 UC 137	509	10	185.5
326ASB(UC)1871 [†]	310 UC 118	507	16	187.1
322ASB(UC)1926 [†]	310 UC 137	509	12	192.6
320ASB(UC)2059 [†]	310 UC 158	511	10	205.9
326ASB(UC)2067 [†]	310 UC 137	509	16	206.7
322ASB(UC)2130 [†]	310 UC 158	511	12	213.0
330ASB(UC)2208 [†]	310 UC 137	509	20	220.8
330ASB(UC)2412 [†]	310 UC 158	511	20	241.2
338ASB(UC)2695 [†]	310 UC 158	511	28	269.5

Note: [†]indicates that 2x 50x50x5.0SHS packers are required welded to the bottom plate. Refer to Figure F.3.5.5.