



**SERIES: MAKING HOLES**

**USING TIN SNIPS TO MAKE PENETRATION HOLES  
IN LIGHT GAUGE STEEL (UP TO 0.75MM THICK)**

This sheet shows you how to use tin snips to make large penetration holes in studs, noggin's and top plates in light-gauge steel up to 0.75mm thick. Seek advice from a qualified engineer if you need a large hole in a load-bearing stud.



**1** Mark the position of the hole with a ruler and/ or template.



**2** Before you use your snips, use pipe and duct snips (shown in the diagram) or a carborundum cutter to cut across the diameter of the hole. This will free up the material.



**3** Use a screwdriver to open an entry point for the snips, and then, cut out with either your left-cut or right-cut snips.



**4** If the hole is too close to a stud, you'll need to change to the other snip to finish the cut from the other direction to avoid the stud interfering with the progress of the snips.



**5** When cutting a penetration hole in a boxed stud, use a pre-made template to position a hole at your measured line on either side of the stud. Mark the holes on both sides.



**6** Cut across the diameter of each circle first.



**7** Finally, use your left and right snips to cut out the circles from the top down.

# 75mm box stud penetration

**IMPORTANT:** Refer to scale (cm) drawing above to ensure template is viewed at actual size. Recommended print size A3.

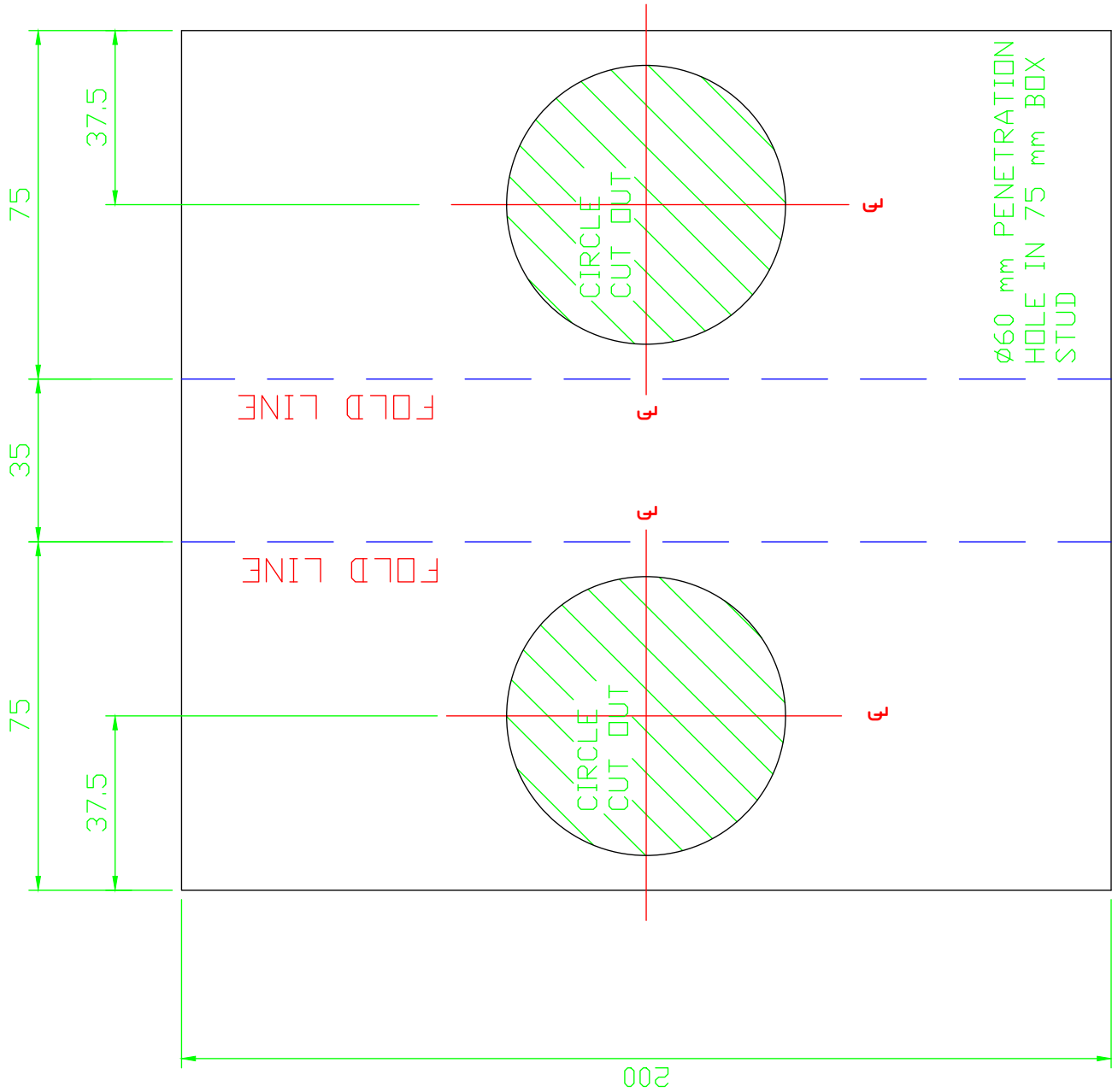
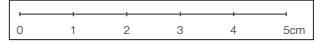

# 75mm stud penetration

**IMPORTANT:** Refer to scale (cm) drawing above to ensure template is viewed at actual size. Recommended print size A3.

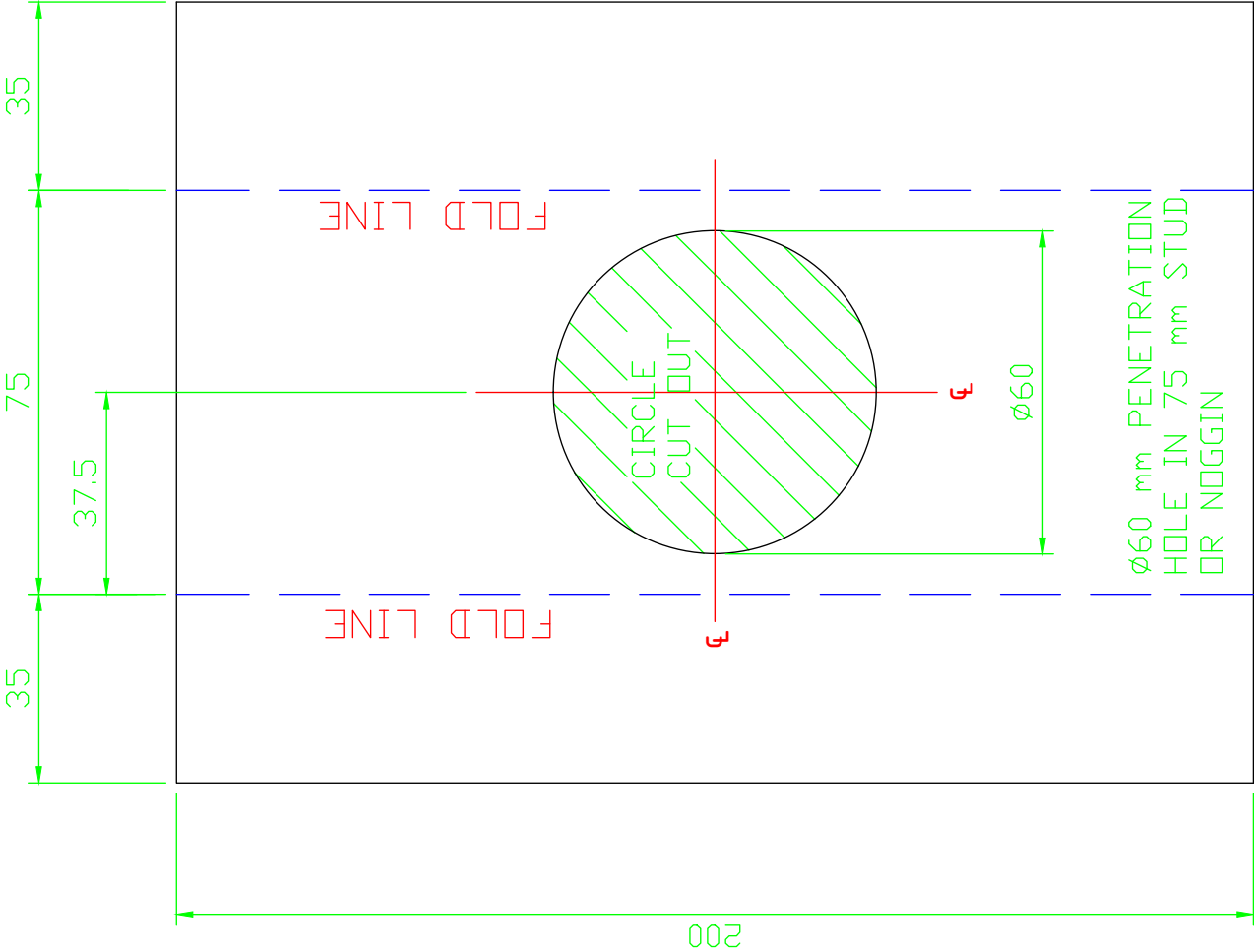

# 90mm box stud penetration

**IMPORTANT:** Refer to scale (cm) drawing above to ensure template is viewed at actual size. Recommended print size A3.

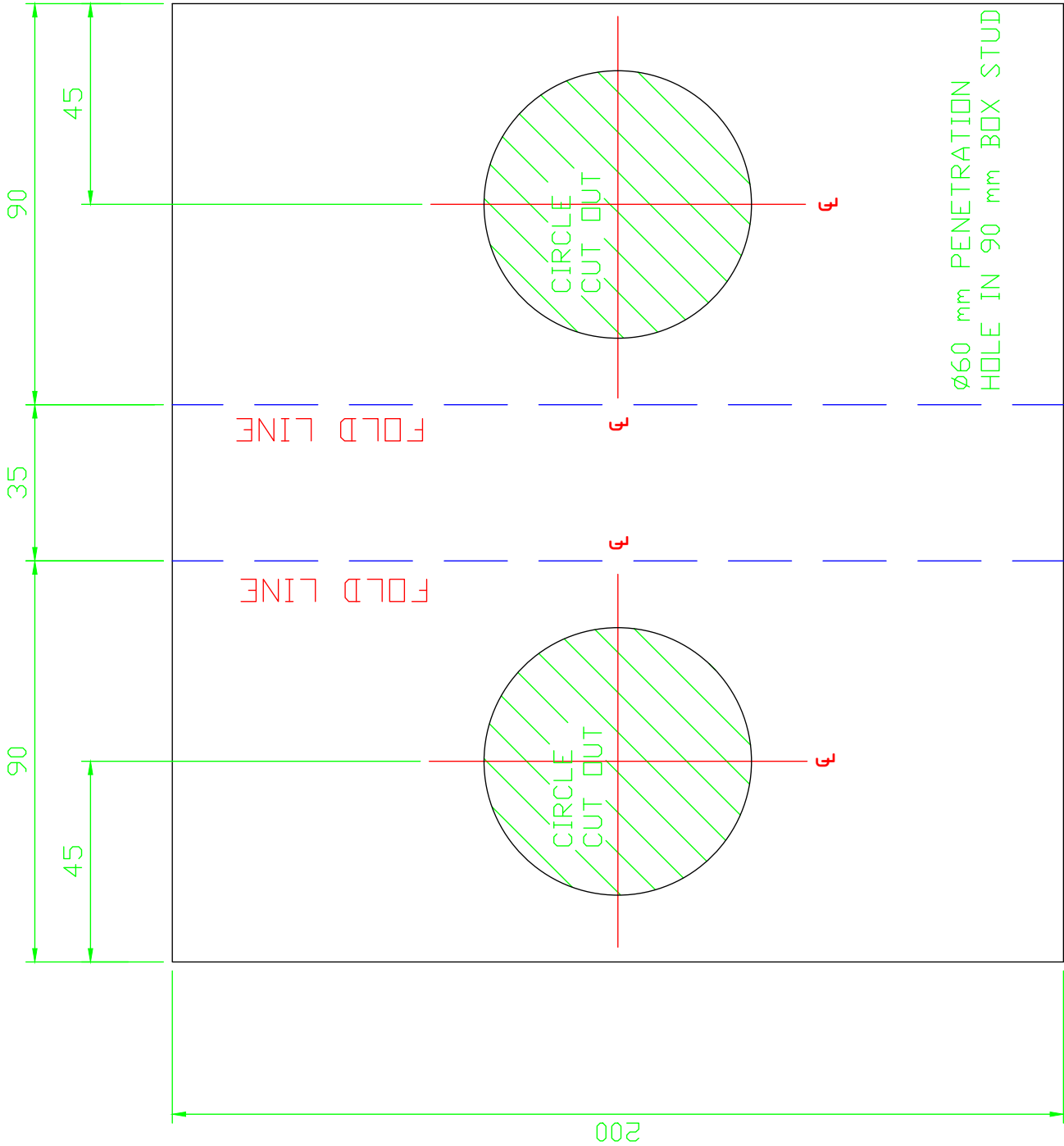

# 90mm stud penetration

**IMPORTANT:** Refer to scale (cm) drawing above to ensure template is viewed at actual size. Recommended print size A3.

